

Total No. of Questions : 6]

SEAT No. :

**P3619**

[Total No. of Pages : 2

**APR-15/ENGG.-102**

**T.E. (Civil) (In Sem - Semester - II)**

**PROJECT MANAGEMENT & ENGG. ECONOMICS**

**(2012 Pattern)**

*Time : 1 Hour]*

*[Max. Marks : 30*

*Instructions to the candidates:*

- 1) *All questions are compulsory.*
- 2) *Figures to the right indicate full marks.*

**Q1)** Attempt the following :

- a) What are the domains of project management? **[4]**
- b) "Poor planning for implementation results in project failure" justify. Enlist any four causes of project failure. **[6]**

OR

**Q2)** Write a short notes on any two :

- a) Project life cycle. **[10]**
- b) PMBOK and PMI.
- c) Delegation of Authority & its importance.

**Q3)** Attempt the following :

- a) Differentiate between CPM and PERT method with the help of example. **[4]**
- b) Data pertains to small construction work, Draw the network diag. find project duration and mark critical path. **[6]**

Activity	1-2	1-3	1-4	2-3	2-5	3-5	4-6	5-6
Duration (Days)	2	4	3	0	1	6	5	7

**P.T.O.**

OR

- Q4) a)** 'Bar chart a simple way of planning & controlling, explain', list out its limitations. **[4]**
- b) Construct network diag. and find out expected project duration. What will be the chances of completing a work in 26 days? The activities of production schedule are as follows : **[6]**

Activity	1-2	1-3	2-4	3-4	3-5	4-5	4-6	5-7	6-7
to	1	1	4	5	2	6	2	3	1
tm	2	4	6	9	4	7	5	5	2
tp	3	7	8	13	12	8	14	13	15

- Q5) a)** What are the methods of manpower planning? **[4]**
- b) Draw time scale version diag. manpower required & Histogram for the given data as follows. **[6]**

Activity	1-2	2-3	2-4	3-7	4-5	4-7	5-6	6-7
Duration (weeks)	3	4	4	4	2	2	3	2
Mason required	2	2	4	6	2	4	2	2

OR

- Q6) a)** Write down step by step procedure of crashing of network diag. and define cost slope. **[5]**
- b) Define updating of network diag. when to update network diag.? **[3]**
- c) Draw a time cost relationship for an activity. **[2]**



Total No. of Questions : 6]

SEAT No. :

P3628

[Total No. of Pages : 2

**APR-15/ENGG.-112**

**T.E. (Automobile Engg.) (In Sem - Semester - II)**

**DESIGN OF ENGINE COMPONENTS**

**(2012 Pattern)**

*Time : 1 hr.30 min.]*

*[Max. Marks : 30*

*Instructions to the candidates:*

- 1) *Answer any Three questions from the following.*
- 2) *Figures to the right indicate full marks.*
- 3) *Neat diagrams must be drawn wherever necessary.*
- 4) *Use of non-programmable calculator is allowed.*
- 5) *Assume suitable data, if necessary.*

**Q1) a) Classify IC engines. [4]**

- b) The engine develops 55KW power with mean effective pressure of 0.8 N/mm<sup>2</sup> and mean piston speed of 600 m/min. Find bore diameter, stroke length, swept volume and engine speed. Select type of engine for maximum performance. Select the engine for pickup truck with 1500 Kg loading capacity. [6]

OR

**Q2) a) Explain engine balancing and its parameters. [4]**

- b) Determine bore diameter, stroke length, swept volume and engine speed for a diesel engine which develops 90KW power with mean effective pressure of 0.6 N/mm<sup>2</sup> and mean piston speed of 600 m/min. [6]

**Q3) a) Explain the different types of cooling systems. [4]**

- b) A two stroke diesel engine was subjected to motoring test. The watt meter reading was 1.6 KW. The engine was then tested for 1 hour and following observations were noted. Net brake torque = 125 Nm, engine rpm = 610, fuel consumption = 2.7 Kg, calorific value of fuel = 41000 Kj/Kg. Calculate brake power, indicated power, mechanical efficiency, indicated thermal efficiency, ISFC, BSFC. [6]

**P.T.O.**

OR

**Q4)** A 4-stroke diesel engine is motored. The meter reading was 5 KW and found the observations during test. Calorific value of fuel = 45 MJ/Kg, brake load = 300 N, engine speed = 1000 rpm, mean effective pressure = 0.8 bar, rise in temperature of cooling water = 10° C, exhaust gas temperature = 450° C, room temperature = 30° C, bore diameter = 0.5 m, stroke length = 0.4 m, mass of fuel = 2.8 Kg, mass of water = 650 Kg, air fuel ratio = 32:1, specific heat of water = 4.187 KJ/Kg k, specific heat of exhaust gas = 1.05 KJ/Kg k. Calculate brake power, indicated power, mechanical efficiency, indicated thermal efficiency. Draw the heat balance sheet on the KJ/min basis and percentage basis. [10]

**Q5)** Calculate the head thickness of cast iron piston for a 4- stroke diesel engine running at 600 rpm and design piston rings with the following data.

Explosion pressure = 4 Mpa, mean effective pressure = 0.75 Mpa, fuel consumption = 0.272 Kg/KW/Hr, diameter of piston = 0.25 m, stroke of piston = 0.3m, efficiency of engine = 80%, HCV = 41870 KJ/Kg, heat conducted through crown = 5% of total heat produced, heat conductivity of cast iron = 460 J/sec.m<sup>2</sup> °C/mm, temperature at the centre of piston = 320° C, temperature at the edge of piston = 150° C, bending stress = 80 Mpa, pressure of the springs = 0.042 Mpa. [10]

OR

**Q6)** Design a connecting rod for 4-stroke petrol engine with the following data. Assume that there is a maximum inertia. Piston diameter = 100mm, stroke = 140mm, length of connecting rod centre to centre = 315mm, mass of reciprocating parts = 1.82Kg, RPM = 2500, maximum explosion pressure = 2.45 Mpa, area of I-section = 11t<sup>2</sup>, radius of gyration = 1.78t mm, factor of safety for buckling of connecting rod = 8, crippling stress = 324Mpa for connecting rod, K = 4/25000 for steel rod, bearing pressure for big end and small end 10Mpa and 14Mpa respectively, tensile stress for bolts = 36.87Mpa. [10]



Total No. of Questions : 6]

SEAT No. :

P3629

[Total No. of Pages : 2

**APR-15/ENGG.-113**

**T.E. (Automobile) (In Sem - Semester - II)**

**AUTOMOTIVE TRANSMISSION**

**(2012 Pattern)**

*Time : 1 Hour]*

*[Max. Marks : 30*

*Instructions to the candidates:*

- 1) *Solve any three questions.*
- 2) *Neat diagrams must be drawn wherever necessary.*
- 3) *Figures to the right indicate full marks.*

- Q1)** a) Explain with neat sketch the different types of chassis-layout with reference to power plant location. [6]
- b) Explain classification of automobile. [4]

OR

- Q2)** a) Explain the following with neat sketch. [6]
- i) Semi - forward chassis.
  - ii) Full - forward chassis.
  - iii) Conventional chassis.
- b) Explain four wheel drive with neat sketch. Why it is necessary? Justify answer with suitable application. [4]

- Q3)** a) What are the standard requirements of clutch? [6]
- b) Explain with neat sketch overdrive unit. [4]

OR

- Q4)** a) Explain electromagnetic clutch with the help of neat sketch. [6]
- b) Draw the neat sketch of gear selector mechanism & explain it in brief.[4]

**P.T.O.**

- Q5)** a) What are the different types of drive lines and explain any one of them with neat sketch. [6]
- b) Explain the following terms. [4]
- i) Driving thrust
  - ii) Torque reaction

OR

- Q6)** a) Explain front engine rear wheel drive layout with the help of neat sketch. [6]
- b) Describe the construction and working of universal joint with neat sketch. [4]



Total No. of Questions : 6]

SEAT No. :

P3630

[Total No. of Pages : 2

**APR-15/ENGG.-114**

**T.E. (Auto.) (In Sem - Semester - II)**

**AUTOMOTIVE AERODYNAMICS & BODY ENGINEERING  
(2012 Pattern)**

*Time : 1 Hour]*

*[Max. Marks : 30*

*Instructions to the candidates:*

- 1) *Answer Q1 or Q2, Q3 or Q4, Q5 or Q6.*
- 2) *Neat diagrams must be drawn wherever necessary.*
- 3) *Figures to the right indicate full marks.*
- 4) *Use of logarithmic tables slide rule, Mollier charts, electronic pocket calculator and steam tables is allowed.*
- 5) *Assume suitable data, if necessary.*

**Q1) a)** Explain in brief about Aerodynamic Drag with types. **[6]**

b) Write a short note on velocity measurement in wind tunnel. **[4]**

OR

**Q2) a)** Calculate the aerodynamic drag running at 75 km/hr & having a frontal projected area 4.2m<sup>2</sup>. Dimensionless coeff. is 0.28, pressure 1.013 bar & temperature is 30° C & gas constant for air 287 kJ/Kg. **[6]**

b) Explain in brief about down force. **[4]**

**Q3) a)** Explain about full scale wind tunnel with neat sketch. **[6]**

b) Describe any four optimization techniques of car for low drag. **[4]**

OR

**Q4) a)** Write a short note on flow visualization techniques used in wind tunnel. **[6]**

b) Explain the strategies for aerodynamic development of car. **[4]**

**P.T.O.**

- Q5)** a) Explain with neat sketch: hatch back, fast back & square back for dust flow pattern at rear. [6]
- b) Explain the role of CFD methodology in aerodynamic development of car. [4]

OR

- Q6)** a) How forces & Moments will act on the vehicle at running condition. [6]
- b) How front end modification reduces the air drag. [4]





Total No. of Questions : 6]

SEAT No. :

P3631

[Total No. of Pages : 2

**APR-15/ENGG.-116**  
**T.E. (Electrical) (In Sem - Semester - II)**  
**POWER SYSTEM - II**  
**(2012 Pattern)**

*Time : 1 Hour]*

*[Max. Marks : 30*

*Instructions to the candidates:*

- 1) *Solve Q1 or Q2, Q3 or Q4, Q5 or Q6.*
- 2) *Neat diagrams must be drawn wherever necessary.*
- 3) *Figures to the right side indicate full marks.*
- 4) *Use of calculator is allowed.*
- 5) *Assume suitable data, if necessary.*

**Q1) a)** A 132kV, three phase line has the following line parameters : **[5]**

$A = 0.98\angle 3^\circ$ ,  $B = 110\angle 75^\circ$  ohms per phase. If the receiving end voltage is 132kV determine:

Sending end voltage and power angle if a load 50MVA at 0.8 p.f. (lagging) is being delivered at receiving end.

b) Explain the term compensation and what are different methods of compensation? **[5]**

OR

**Q2) a)** Derive equation for receiving end active and reactive power flow in the transmission line. **[5]**

b) Explain the procedure for drawing the receiving end circle diagram. **[5]**

**Q3) a)** What are the recent developments in HVDC transmission system? State any two HVDC systems in India. **[5]**

b) Compare HVDC system with EHVAC system. **[5]**

OR

**P.T.O.**

- Q4)** a) Give the classification of HVDC transmission system in detail. [6]  
b) Explain constant current control characteristic of HVDC transmission system. [4]

- Q5)** a) Explain the phenomenon of corona and state factors affecting corona loss. [4]  
b) Find the disruptive critical voltage and visual critical voltage for local and general corona for a three phase line consisting of 21mm diameter conductors spaced in 6 m delta configuration. Take temperature  $25^{\circ}\text{C}$ , pressure 73 cm of mercury, surface factor 0.84, irregularity factor for local visual corona 0.72 and for general (decided) visual corona 0.82. [6]

OR

- Q6)** a) In three phase overhead line the conductors have each diameter of 30mm and are arranged in the form of an equilateral triangle. Assuming fair weather conditions air density factor is 0.95 and irregularity factor 0.95. Find the minimum spacing between the conductors if the disruptive critical voltage is not to exceed 230kV between lines. Breakdown strength of air may be assumed to be 30kV per cm (peak). [6]  
b) Explain power handling capacity and power loss at various voltage levels. [4]



**APR-15/ENGG.-117**  
**T.E. (Electrical) (In Sem - Semester - II)**  
**CONTROL SYSTEM - I**  
**(2012 Pattern)**

*Time : 1 Hour]*

*[Max. Marks : 30*

*Instructions to the candidates:*

- 1) *Use of non programmable calculator is allowed.*
- 2) *Solve Q1 or Q2, Q3 or Q4, Q5 or Q6.*
- 3) *Figures to the right indicate full marks.*
- 4) *Assume suitable data, if necessary.*

- Q1) a) Compare open loop and closed loop system. [4]**  
 b) Obtain the transfer function of the signal flow graph given below. [6]

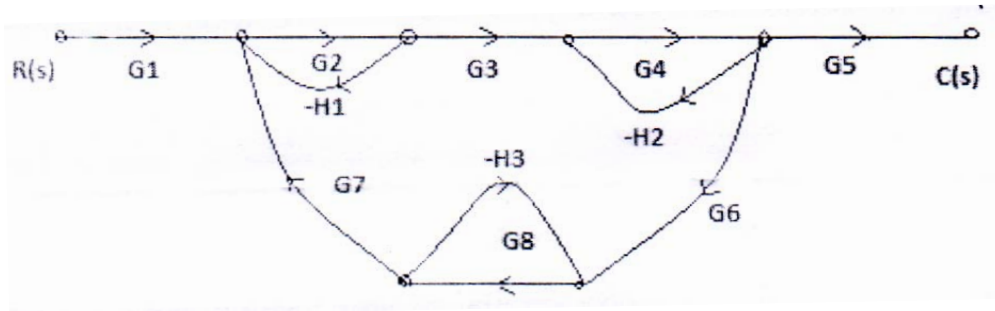

OR

- Q2) a) Define the following control systems and give example of each. [3]**  
 i) Tracking Control System,  
 ii) Regulator Control System and  
 iii) Feed Forward Control System  
 b) Obtain the transfer function of the block diagram given below. [7]

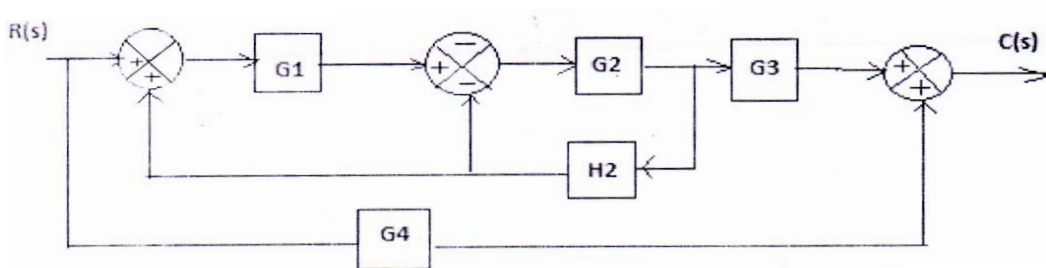

- Q3)** a) What is a lag network? Obtain the transfer function of lag network. [4]
- b) Obtain the block diagram representation of armature control DC servo motor with output as angular velocity ( $W$ ) and input as armature voltage ( $V_a$ ). Consider following parameters for transfer function  $R_a$ -Armature resistant (ohm),  $L_a$ -armature inductance (H),  $V_a$ -Armature voltage (V),  $E_b$ -Back emf (V),  $I_a$ -armature current (A),  $W$ -Angular velocity (rad/sec),  $T$ -Torque (Nm),  $J$ -Moment of inertia (Kg m<sup>2</sup>),  $K_t$ -back emf and torque constant (Vsec/rad),  $B$ -load torque friction constant. [6]

OR

- Q4)** a) Explain AC servomotor working characteristics features and its transfer function. [6]
- b) Explain potentiometer and potentiometer as error detector. Obtain the transfer function of potentiometer. [4]
- Q5)** a) Write short note on dominant closed loop poles of higher order system.[3]
- b) Consider the system given below. Obtain closed loop transfer function and determine (i) Rise time, (ii) Peak Time, (iii) Maximum Overshoot (iv) Settling time and (v)Delay Time. [7]

$$G(s) = \frac{136}{s^2 + 16s + 136}$$

OR

- Q6)** a) Draw the standard test signals. Write their mathematical representations and Laplace transform. [4]
- b) A second order system is represented by the transfer function

$$\frac{W(S)}{T(S)} = \frac{1}{Js^2 + fs + k}$$

A step input of 10 Nm is applied to the system and the test results are  
 (i) Maximum overshoot 6 %, (ii) Peak time 1 sec, (iii) Steady state  
 value of output is 0.5 rad. Determine values of  $J$ ,  $f$  and  $k$ . [6]

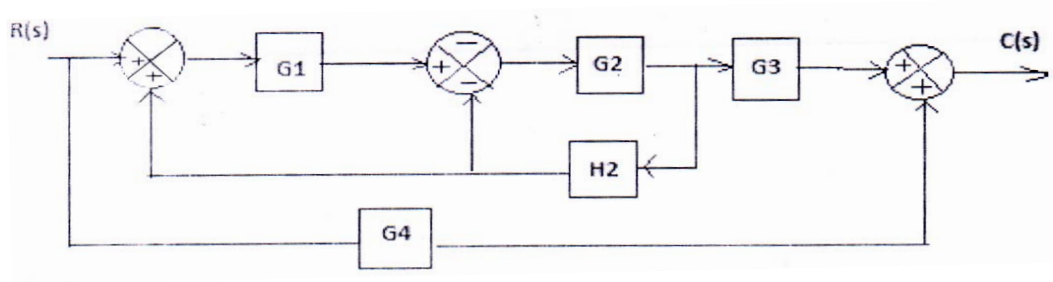

Total No. of Questions : 6]

SEAT No. :

P3633

[Total No. of Pages : 2

**APR-15/ENGG.-118**

**T.E. (Electrical) (In Sem - Semester - II)**

**UTILIZATION OF ELECTRICAL ENERGY**

**(2012 Pattern)**

*Time : 1 Hour]*

*[Max. Marks : 30*

*Instructions to the candidates:*

- 1) *Answer Q1 OR Q2, Q3 OR Q4, Q5 OR Q6.*
- 2) *Neat diagrams must be drawn wherever necessary.*
- 3) *Assume suitable data, if necessary.*
- 4) *Figures to the right indicate full marks.*

**Q1) a)** Explain any four advantages of an Electrical heating. **[4]**

- b) A resistance oven employing nichrome wire is to be operated from 220 V, single phase supply and is to be rated at 16 kW. If the temperature of the element is to be limited to 1170 °C and average temperature of the charge is 500 °C. Find the diameter and length of the element wire. Radiating efficiency = 0.57, emissivity = 0.9, specific resistance of nichrome =  $109 \times 10^{-8} \Omega\text{m}$ . **[6]**

OR

**Q2) a)** Describe Ajax Wyatt induction furnace with neat diagram. **[4]**

- b) A piece of insulating material is to be heated by dielectric heating. The size of the piece is 12 cm × 12 cm × 3cm. A frequency of 20 mega cycles is used and the power absorbed is 450 watt. Calculate the voltage necessary for heating and the current flowing through the material. The material has relative permittivity of 5 and power factor of 0.05. If the voltage were limited to 1700 V, what will be the frequency to get the same loss. **[6]**

**Q3) a)** Explain vapour compression refrigeration cycle with neat diagram. **[4]**

- b) Explain factors on which the quality of Electro – Deposition depends. **[6]**

**P.T.O.**

OR

- Q4) a)** Write a short note on Electroplating. [4]  
b) With a suitable diagram explain electric circuit used in refrigerator. [6]

- Q5) a)** Define following terms and state its unit. [4]  
i) Luminous Flux  
ii) Luminous Intensity  
iii) Solid Angle  
iv) Coefficient of Utilization
- b) Two lamps are suspended at a height of 9 meter from the floor level. The distance between the lamps is 2 meter. Lamp one is of 500 candle power. If the illumination on the floor vertically below this lamp is 20 lux. Find the candle power of the lamp two. [6]

OR

- Q6) a)** Explain Sodium Vapour lamp with neat diagram. [4]  
b) A lamp with a reflector is mounted 12 meter above the centre of a circular area of 24 meter diameter. If the combination of the lamp and reflector gives a uniform CP of 1000 over the circular area, determine the maximum and minimum illumination produced on the area. [6]



Total No. of Questions : 6]

SEAT No. :

**P3634**

[Total No. of Pages : 2

**APR-15/ENGG.-119**

**T.E. (Electrical) (In Sem - Semester - II)**

**DESIGN OF ELECTRICAL MACHINES**

**(2012 Pattern)**

*Time : 1 Hour]*

*[Max. Marks : 30*

*Instructions to the candidates:*

- 1) *Answer Q1 or Q2, Q3 or Q4, Q5 or Q6.*
- 2) *Neat diagrams must be drawn wherever necessary.*
- 3) *Figures to the right indicate full marks.*
- 4) *Use of logarithmic table, slide rule, Mollier chart, electronic pocket calculator and steam table is allowed.*
- 5) *Assume suitable data, if necessary.*

- Q1)** a) What are the various specifications of transformer as per IS 2026? [4]  
b) An induction motor has a final steady temperature rise of 40° C when running at its rated output. Calculate its half hour rating for the same temperature rise if the copper losses at rated output are 1.25 times its constant losses. The heating time constant is 90 minutes. [6]

OR

- Q2)** a) Write the functions of tap changer, pressure release valve, conservator and breather? [4]  
b) A 100 kVA transformer has an efficiency of 98 percent at full load and 0.8 power factor. For the purpose of cooling, the transformer may be considered to be 1200 kg of homogeneous material having a specific heat of 700 J/kg-°C and a surface area of 10 m<sup>2</sup>, the surface emitting heat at 12 W/m<sup>2</sup>-°C. Find the thermal time constant and the full load temperature rise. [6]

- Q3)** a) Derive output equation of 3-phase transformer with usual notations. [4]  
b) The tank of a 1250 kVA natural oil cooled transformer has the dimensions length, width and height as 1.55 m × 0.65 m × 1.85 m respectively. The full load loss is 13.1 kW. Find the number of cooling tubes for this transformer assuming: W/m<sup>2</sup>-°C due to radiation = 6; W/m<sup>2</sup>-°C due to convection = 6.5; improvement in convection due to provision of tubes = 40 percent; temperature rise = 40°C; length of each tube = 1 m; diameter of tubes = 50 mm. Neglect the top and bottom surfaces of the tank as regards cooling. [6]

**P.T.O.**



OR

- Q4)** a) List the assumptions made while deriving the equation for leakage reactance of three phase core type transformer. [4]
- b) Determine the dimensions for core and yoke for a 5kVA, 50 Hz, single phase core type transformer. A rectangular core is used with long side twice as long as short side. The window height is 3 times the width. Voltage per turn = 1.8 V; space factor = 0.2; current density = 1.8 A/mm<sup>2</sup>; flux density = 1 Wb/m<sup>2</sup>; stacking factor = 0.9. [6]
- Q5)** a) Derive the expression of average radial force produced in case core type transformer. [4]
- b) A 220/110 V, 1 kVA, 50 Hz single phase transformer has a core with a uniform cross sectional area of 2500 mm<sup>2</sup>, an effective magnetic core length of 0.4 m and a core weight of 8 kg. If the core is worked at a maximum flux density of 1.2 Wb/m<sup>2</sup>, the corresponding magnetizing force is 200 A/m and the specific core loss is 1.0 W/kg, determine the transformer no load current when the h.v. is fed at 220 V. [6]

OR

- Q6)** a) Derive the expression for calculation of no load current of three phase core type transformer. [5]
- b) Write a generalized flow chart for design of electrical machines. [5]



Total No. of Questions : 3]

SEAT No. :

**P3635**

[Total No. of Pages : 2

**APR-15/ENGG.-120**  
**T.E. (Electrical) (In Sem - Semester - II)**  
**ENERGY AUDIT & MANAGEMENT**  
**(2012 Pattern)**

*Time : 1 Hour]*

*[Max. Marks : 30*

*Instructions to the candidates:*

- 1) *Attempt all questions.*
- 2) *All questions carry equal marks.*
- 3) *Neat diagrams must be drawn wherever necessary.*
- 4) *Assume suitable data, if necessary.*

**Q1) a)** Explain long term energy policies suitable for growing Indian economy. **[6]**

OR

Give salient features of Electricity Act 2003.

b) With suitable example classify energy sources. **[4]**

OR

Explain briefly impact of uncontrolled use of commercial energy sources on environment.

**Q2) a)** Discuss principles of successful energy management. **[6]**

OR

What is energy policy? Give format of energy policy.

b) What are the responsibilities of energy manager? **[4]**

OR

Give the structure of energy management division in process industry.

**P.T.O.**

**Q3) a)** Explain various load curve shaping tools used in demand management.[7]

OR

Explain utility side management avenues for management of power network.

b) Explain features of SCADA system. [3]

OR

State limitations of Supply Side Management.



Total No. of Questions : 6]

SEAT No. :

P3636

[Total No. of Pages : 2

**APR-15/ENGG.-121**

**T.E. (E & TC ) (In Sem - Semester - II)**

**Information Theory & Coding Techniques  
(2012 Pattern)**

*Time : 1 Hour]*

*[Max. Marks : 30*

*Instructions to the candidates:*

- 1) *Answer Q.1 or Q.2, Q.3 or Q.4, Q.5 or Q.6.*
- 2) *Neat diagrams must be drawn wherever necessary.*
- 3) *Figures to the right indicate full marks.*
- 4) *Use of logarithmic tables slide rule, Mollier charts, electronic pocket calculator and steam tables is allowed.*
- 5) *Assume suitable data, if necessary.*

**Q1) a)** A source generates four types of symbols A, B, C, D with probabilities 0.5, 0.25, 0.125 and 0.125 respectively **[6]**

- i) Using Huffman coding technique design source encoder.
- ii) Find coding efficiency.
- iii) If following message is generated by source, What will be output of the source encoder ABADCABA.

b) What is Lempel-Ziv compression technique? Explain with suitable example. **[4]**

OR

**Q2) a)** What is mutual information? State and prove any one property of mutual information. **[4]**

b) Find all entropies, mutual information of channel where channel matrix is given as

$$P(Y / X) = \begin{bmatrix} 0.7 & 0.3 \\ 0.3 & 0.7 \end{bmatrix}$$

Take  $P(x_1) = 0.6$  and  $P(x_2) = 0.4$ . **[6]**

**P.T.O.**

**Q3) a)** A voice grade telephone channel has a bandwidth 3400 Hz. If the signal-to-noise ratio is 30 dB; determine the capacity of the channel. If above channel is used to transmit data at a rate 48 kbps, What is minimum required SNR? [4]

b) For a (6, 3) linear block code, following generator matrix is used. [6]

$$G = \begin{bmatrix} 1 & 0 & 0 & 1 & 1 & 0 \\ 0 & 1 & 0 & 0 & 1 & 1 \\ 0 & 0 & 1 & 1 & 1 & 1 \end{bmatrix}$$

- i) Find error correction & detection capability of the code
- ii) Is this a perfect code? Justify.

OR

**Q4) a)** Prove that the capacity of noiseless channel is  $\log_2^m$ , where m is number of symbols generated by the source. [6]

b) State Shannon's second theorem. A Gaussian channel has a bandwidth of 1 MHz. Calculate capacity of channel if signal-to-noise power spectral density ratio is  $10^5$  Hz. [4]

**Q5) a)** Using generator polynomial  $g(x) = x^3 + x + 1$  generate systematic cyclic code for following messages. [6]

i) 1011

ii) 1010

b) Using primitive polynomial  $P(x) = x^3 + x + 1$ , find all elements of  $GF(2^3)$ . [4]

OR

**Q6) a)** For a (7, 4) cyclic code, generator polynomial  $g(x) = x^3 + x + 1$  is used. Draw the circuit for generating syndrome. Find syndrome for received code word 0011000. [6]

b) What is Galois field? Write properties finite field. [4]



Total No. of Questions : 6]

SEAT No. :

P3637

[Total No. of Pages : 2

**APR-15/ENGG.-122**

**T.E. (Electronics & Telecommunication) (In Sem - Semester - II)**

**ANTENNA AND WAVE PROPAGATION**

**(2012 Pattern)**

*Time : 1 Hour]*

*[Max. Marks : 30*

*Instructions to the candidates:*

- 1) *Solve any three questions (Q1 OR Q2, Q3 OR Q4 and Q5 OR Q6).*
- 2) *Figures to the right indicate full marks.*
- 3) *Assume suitable data wherever necessary.*

- Q1)** a) What is polarization & Explain polarized wave and unpolarized wave. **[4]**  
b) A uniform plane wave with 25v/m electric field is normally incident on an infinitely thick slab of material of dielectric constant 5. Find electric and magnetic fields inside the slab surface. How much power penetrates the material slab? **[6]**

OR

- Q2)** a) State Poynting theorem for time varying Electromagnetic wave. **[5]**  
b) Write Maxwell's Equation in phasor form of time varying Electromagnetic wave. **[5]**

- Q3)** a) Explain in detail factors affecting the performance of Wireless Channel. **[6]**  
b) Two planes 15 km apart are in radio communication. The transmitting plane delivers 500 watt. Its antenna gain being 10 in the direction of other plane, Power observed is 2 microwatts by the receiving antenna of the second plane. Find the effective area. **[4]**

OR

- Q4)** a) With reference of sky wave define, **[6]**  
i) Virtual height  
ii) Critical frequency  
iii) MUF  
b) Derive the Friis transmission equation for free space propagation. **[4]**

**P.T.O.**

- Q5) a)** Explain radiation mechanism of antenna. **[4]**
- b) A lossless antenna has input impedance of  $75\Omega$ , maximum effective aperture of  $2.147 \text{ (m}^2\text{)}$  at a operating frequency of 100 MHz. Antenna is connected to  $50\Omega$  transmission line. Find directivity of the antenna assuming no polarization loss. **[6]**

OR

- Q6) a)** Explain the following term with respect to antenna. **[5]**
- i) Gain
  - ii) Radiation intensity
  - iii) Radiation power density
- b) Derive vector potential 'F' for an magnetic current source 'M'. **[5]**



Total No. of Questions : 6]

SEAT No. :

P3646

[Total No. of Pages : 2

**APR-15/ENGG.-131**

**T.E. (Instrumentation & Control) (In Sem - Semester - II)**

**DIGITAL SIGNAL PROCESSING**

**(2012 Pattern)**

*Time : 1 Hour]*

*[Max. Marks : 30*

*Instructions to the candidates:*

- 1) *Solve any three questions.*
- 2) *Figures to the right indicate full marks.*

**Q1)** a) Define signal explain the different ways of representation of signal? [5]

b) Justify whether given signal is periodic or not, if periodic find its period.[5]

i)  $x(n) = e^{j7\pi n}$

ii)  $x(n) = \cos(\pi n/4) + \sin(\pi n/8)$

OR

**Q2)** a) Determine the following system is linear & causal  $Y(n) = X(n^2)$ . [2]

b) Determine linear convolution of the following signals [8]

$x(n) = \{1, 2, 1, 1\}$   $h(n) = \{3, 2, 1, 1\}$ .

**Q3)** a) Explain any two properties of Z-Transform & find Z-Transform of the Term  $K^2$ . [5]

b) Find inverse Z-Transform of the following response [5]

$$X(z) = \frac{Z^{-1}(1 - Z^{-2})}{(1 + Z^{-2})^2}$$

**P.T.O.**



OR

**Q4) a)** Explain the concept of ideal frequency selective filter with neat diagram?[4]

b) Determine the magnitude & phase response of LTI system given by  $y(n)+1/2y(n-1)+x(n-1) = x(n)$  use angular frequency  $w = (0,\pi/2)$ . [6]

**Q5) a)** Explain any two properties of DFT with proof? [4]

b) Compute 4-Point DFT of following sequence [6]

$$X(n) = \{1, -1, 1, -1\}.$$

OR

**Q6) a)** Find IDFT of the given sequence  $X(k) = \{1\ 3\ 2\ 4\}$ . [5]

b) Find Circular convolution using Graphical method of the given two Sequence  $X_1(n) = \{1\ 2\ 2\ 1\}$  &  $X_2(n) = \{3\ 2\ 1\ 1\}$ . [5]



Total No. of Questions : 6]

SEAT No. :

**P3649**

[Total No. of Pages : 2

**APR - 15 / Engg. - 134**

**T.E. (Instrumentation & Control Engineering) (In Sem - Semester - II)**

**INSTRUMENT AND SYSTEM DESIGN**

**(2012 Pattern)**

*Time : 1 Hour]*

*[Max. Marks : 30*

*Instructions to the candidates:*

- 1) Solve one question each from Q.1 or Q.2, Q.3 or Q.4, and Q.5 or Q.6.*
- 2) Each question should be solved on a new page.*
- 3) Neat labelled diagrams are expected.*
- 4) Assume suitable data if required.*

- Q1)** a) Briefly explain the different phases of product life cycle. [7]
- b) What is the need of instrument specifications? Give functional requirements. [3]

OR

- Q2)** a) Write a short note on prototyping. [4]
- b) Define standards. Explain Ingress Protection standard. [6]

- Q3)** a) Prove that thermal noise is independent of composition of resistor under thermal equilibrium. [6]
- b) What is the need of Ergonomics? State its three principle domains. [4]

OR

- Q4)** a) Define tribo-electric effect. Explain ESD minimization guidelines for enclosures. [5]
- b) Define grounding and its types. Explain hybrid grounding technique. [5]

**P.T.O.**

- Q5)** a) Draw internal diagram of AD 594 and explain its operation. [6]  
b) How AD 620 IC can be used as precision voltage to current converter?  
Also enlist features of IC. [4]

OR

- Q6)** a) With appropriate circuit diagram, explain how IC HCNR 201 can be configured for positive input and positive output. [4]  
b) Design pressure transmitter for  
i) Output of pressure transducer and signal conditioning = 0 to 5V for input pressure 0 to 20 psi  
ii) Output current = 0 to 20 mA  
Draw the circuit connections. [6]



Total No. of Questions : 6]

SEAT No. :

**P3650**

[Total No. of Pages : 2

**APR - 15 / Engg. - 135**

**T.E. (Instrumentation & Control Engineering) (In Sem - Semester - II)**

**BIOMEDICAL INSTRUMENTATION**

**(2012 Pattern)**

*Time : 1 Hour]*

*[Max. Marks : 30*

*Instructions to the candidates:*

- 1) *Answer Q.1 or Q.2, Q.3 or Q.4, Q.5 or Q.6.*
- 2) *Neat diagrams must be drawn wherever necessary.*
- 3) *Figures to the right indicate full marks.*
- 4) *Assume suitable data if necessary.*

**Unit - I**

- Q1)** a) Define bio electrode? Name various types of basic bio electrodes used for bioelectric potential measurements. Explain the necessity of micro-electrode, Micropipette electrode. **[4]**
- b) Define any three of following:  
half cell potential, offset potential, action potential. Resting potential, Evoked potential. **[3×2=6]**

OR

- Q2)** a) Why silver - silver chloride electrode is suitable in biomedical applications. **[4]**
- b) Explain Physiological parameters & suitable transducers for its measurements, operating principles (Any Two) **[6]**

**Unit - II**

- Q3)** a) Explain different Chambers of heart. Explain an Electrical conduction system of heart. **[5]**
- b) Discuss the various Bio-polar ECG leads configuration in detail. **[5]**

OR

**P.T.O.**

- Q4)** a) Enlist various preamplifiers used in bio signal conditioning? What are limitations of differential amplifier and explain how it overcomes with improved version of the same [5]
- b) Draw and explain Heart Rate meter. [5]

**Unit - III**

- Q5)** a) Enlist two important techniques used in sphygmomanometer BP measurement. Explain its advantages and disadvantages. [5]
- b) Define Cardiac output And Calculate the cardiac output for heart rate of 85 beats / min. and stroke volume of 65 ml. [5]

OR

- Q6)** a) What are various blood flow measurement techniques? What are the problems faced by magnetic blood flow meters if they using permanent magnets or DC excitation. [5]
- b) Explain phonocardiography with neat diagram [5]



Total No. of Questions : 6]

SEAT No. :

**P3651**

[Total No. of Pages : 2

**APR - 15 / Engg. - 136**

**T.E. (Chemical) (In Sem - Semester - II)**

**CHEMICAL REACTION ENGINEERING - I**

**(2012 Pattern)**

*Time : 1½ Hour]*

*[Max. Marks : 30*

*Instructions to the candidates:*

- 1) *Answer Q.1 or Q.2, Q.3 or Q.4, Q.5 or Q.6.*
- 2) *Neat diagrams must be drawn wherever necessary.*
- 3) *Figures to the right indicate full marks.*
- 4) *Assume suitable data if necessary.*

**Unit - I**

- Q1)** a) Define molecularity, order of reaction and rate constant. [5]  
b) On doubling the concentration of the reactant, the rate of reaction triples. Find the reaction order. [5]

OR

- Q2)** The pyrolysis of ethane proceeds with an activation energy of about 75000 cal/mole. How much faster is the decomposition at 650 °C than at 500 °C. [10]

**Unit - II**

- Q3)** For first order reaction with variable volume show that [10]  
$$-\ln [1 - \Delta V/\epsilon_A V_0] = k.t$$

OR

- Q4)** a) Explain the differential method of analysis of batch reactor data in detail. [5]  
b) Liquid A decomposes by first order kinetics and in a batch reactor 50% of A is converted in a 5 minute run. How much longer would it take to reach 75% conversion? [5]

**P.T.O.**

**Unit - III**

**Q5)** Develop performance equation for the plug flow reactor with its graphical representation. **[10]**

OR

**Q6)** Pure gaseous A at about 3atm and 30°C (120mmol/lit) is fed into 1 liter mixed flow reactor at various flow rates. There it decomposes, and the exit concentration of A is measured for each flow rate. From the following data find a rate equation to represent the kinetics of the decomposition of A. Assume that reactant A alone affects the rate.  $A \rightarrow 3R$ . **[10]**

$v_0$ , lit/min	0.06	0.48	1.5	8.1
$C_A$ , mmol/lit	30	60	80	105

❖❖❖

Total No. of Questions : 6]

SEAT No. :

**P3652**

[Total No. of Pages : 2

**APR - 15 / Engg. - 137**

**T.E. (Chemical) (In Sem - Semester - II)**

**TRANSPORT PHENOMENA**

**(2012 Pattern)**

*Time : 1½ Hour]*

*[Max. Marks : 30*

*Instructions to the candidates:*

- 1) *Answer Q.1 or Q.2, Q.3 or Q.4, Q.5 or Q.6.*
- 2) *Neat diagrams must be drawn wherever necessary.*
- 3) *Figures to the right indicate full marks.*
- 4) *Assume suitable data if necessary.*
- 5) *Use of logarithmic tables sliderule, Mollier charts, electronic pocket calculator and steam tables is allowed.*

**Q1)** Derive Hagen Poiseuille equation for flow of a Newtonian fluid through the tube. **[10]**

OR

**Q2)** a) Explain Bingham model of non-Newtonian fluid. **[4]**

b) A horizontal annulus is 27 ft long. Outer radius of inner cylinder is 0.495 in., and inner radius of outer radius is 1.1 in. An aqueous solution of sucrose is to be pumped having viscosity of  $136.8 \text{ lb}_m \text{ ft}^{-1} \text{ hr}^{-1}$ . What is volumetric flow rate if pressure drop is 5.39 psi. **[6]**

**Q3)** Derive expression of heat flux and temperature distribution for electrical heat source. **[10]**

OR

**Q4)** a) Explain Fourier's law of heat conduction. **[4]**

b) Explain procedure to set up and solve heat transfer problems. **[6]**

**P.T.O.**



**Q5)** Derive the expression of molar flux and concentration profile for diffusion through stagnant gas. **[10]**

OR

**Q6)** a) Explain mass balance equation at steady state. **[4]**

b) The solute HCl is diffusing through a thin film of water 2 mm. Conc. of HCl at point 1 is 12 wt% (density = 1061 kg/m<sup>3</sup>) and at point 2 is 6 wt% (density = 1030kg/m<sup>3</sup>). Diffusivity of HCl in water is  $2.5 \times 10^{-9}$ m<sup>2</sup>/s. Calculate flux of HCl in kmol/m<sup>2</sup>s. **[6]**



Total No. of Questions : 6]

SEAT No. :

**P3653**

[Total No. of Pages : 2

**APR - 15 / Engg. - 138**

**T.E. (Chemical Engineering) (In Sem - Semester - II)**

**CHEMICAL ENGINEERING DESIGN - I**

**(2012 Pattern)**

*Time : 1 Hour]*

*[Max. Marks : 30*

*Instructions to the candidates:*

- 1) *Answer Q.1 or Q.2, Q.3 or Q.4, Q.5 or Q.6.*
- 2) *Neat diagrams must be drawn wherever necessary.*
- 3) *Figures to the right indicate full marks.*
- 4) *Assume suitable data, if necessary.*
- 5) *Use of log table, calculator and steam table is permitted.*

- Q1)** a) Discuss the various losses in storage vessels. **[4]**
- b) A storage vessel is to be covered by using a conical roof. Check the suitability of 10 mm thick plates for the construction of conical roof with permissible slope of 1 in 5. Superimposed load = 1250 N/m<sup>2</sup>, density of steel = 7700 kg/m<sup>3</sup>. Diameter of vessel = 10 m. If the plates are not suitable, suggest the required thickness for roof plates. **[6]**

OR

- Q2)** a) A storage tank has to store 30,000 kg of benzene having density 800 kg/m<sup>3</sup>. Due to space limitations the maximum tank diameter can be 2.4 m. Estimate the height of the tank if the liquid is filled upto 90 % of the capacity of storage tank. **[4]**
- b) Discuss the stresses in cone roof. **[6]**

- Q3)** a) Discuss the stresses in shell of tall vertical column. **[6]**
- b) Give the step by step method for designing the skirt thickness due to dead weight of vessel and due to wind load. **[4]**

OR

**P.T.O.**

**Q4)** Design the saddle support with help of following data. **[10]**

Material of construction = low carbon steel.

Vessel diameter = 1230 mm.

Length of shell = 8000 mm.

Torispherical head:

Crown radius = 1250 mm.

Knuckle radius = 6 % of diameter.

Total depth = 257 mm.

Working pressure = 0.5 N/mm<sup>2</sup>.

Shell thickness = 10 mm.

Head thickness = 12 mm.

Corrosion allowance = 1.5 mm.

Permissible Stress = 95 N/mm<sup>2</sup>.

Load of vessel and its contents = 12000 kg.

Distance of saddle centerline from shell end = 320 mm.

For  $\theta = 120^\circ$ ,  $k_1 = 0.107$  and  $k_2 = 0.192$

**Q5)** a) What are the advantages of plate heat exchangers ? With neat sketches show the various flow patterns in plate heat exchangers. **[5]**

b) What do you mean by LMTD? Why it is used in heat exchanger design? **[5]**

OR

**Q6)** 3000 kg/hr of furnace oil is to be heated from 10° to 90° C in a shell and tube heat exchanger. Heating is done by steam available at 120° C. Oil is circulated through the tubes while steam is circulated in shell. Tubes of 16.5 mm ID & 19 mm OD are available. Length of tubes is 3 m. The film coefficient of heat transfer for oil is 90 W/m<sup>2</sup> °K, while film coefficient of heat transfer for condensing steam is 7400 W/m<sup>2</sup> °K.

Density of furnace oil = 900 kg/m<sup>3</sup>.

Specific heat of furnace oil = 1970 J/kg °K.

Fouling resistance for furnace oil = 0.0009m<sup>2</sup> K/W.

Fouling resistance for steam side = 0.00005m<sup>2</sup> K/W.

Suggest a suitable design of the shell and tube heat exchanger. Maximum oil velocity that can be used is 0.05 m/sec. Estimate the number of passes on tube side required in heat exchanger. **[10]**



Total No. of Questions : 6]

SEAT No. :

**P3654**

[Total No. of Pages : 3

**APR - 15 / Engg. - 139**

**T.E. (Chemical Engg.) (In Sem - Semester - II)**

**MASS TRANSFER - II**

**(2012 Pattern)**

*Time : 1½ Hours]*

*[Max. Marks : 30*

*Instructions to the candidates:*

- 1) *Answer Q.1 or Q.2, Q.3 or Q.4, Q.5 or Q.6.*
- 2) *Neat diagrams must be drawn wherever necessary.*
- 3) *Figures to the right indicate full marks.*
- 4) *Assume Suitable data if necessary.*
- 5) *Use of logarithmic tables slide rule, Mollier charts, electronic pocket calculator and steam tables is allowed.*

**Q1)** a) Explain in brief extractive distillation and azeotropic distillation. **[5]**

- b) A liquid mixture is subjected to differential distillation containing 50- mole% n-heptane and 50- mole% n-octane at atmospheric pressure until the residual liquid contain 35mole% n-heptane. Find out the % of feed left over as residue **[5]**

X-        0.5    0.46    0.42    0.38    0.34    0.32

Y-        0.689   0.648   0.608   0.567   0.523   0.49

OR

**Q2)** a) A liquid mixture containing 40 wt% benzene and 60 wt% toluene is subjected to flash distillation at pressure 101.325 kPa. If the fraction of feed vaporized is 0.50, calculate the equilibrium composition of vapour and liquid. **[5]**

X:- 0.05   0.1   0.2   0.3   0.4   0.5   0.6   0.7   0.8   0.9   1.0

Y:- 0.13   0.21   0.375   0.5   0.6   0.7   0.77   0.83   0.9   0.95   1.0

- b) What is distillation? Define differential distillation and derive Rayleigh equation. **[5]**

**P.T.O.**

- Q3)** a) A binary mixture of methanol 30 wt% and ethanol 70 wt% is to be separated by fractionation to obtain each of 95 wt % purity. Calculate the min reflux if the feed is 30 % vaporized. The data given is as follows. **[5]**

Temp°C	64	67	70	73	76	78
P°(CH <sub>3</sub> OH)	760	820	920	1020	1150	1260
P°(C <sub>2</sub> H <sub>5</sub> OH)	420	430	470	610	690	760

- b) What are the drawbacks of Mc -Cabe Thiele method? Derive equation of q-line and give its significance. **[5]**

OR

- Q 4)** Partially vaporized feed of composition 42 mole% heptanes and 58 mole% ethyl benzene is to be fractionated at 1 atm to give distillate containing 95 mole % heptanes and bottom containing 95 mole % ethyl benzene. The feed is 40% liquid and 60% vapor (all in mole basis) calculate a) value of q and slope of q-line, b) min. reflux ratio, c) number of plates at R = 2.5, the equilibrium data is **[10]**

X - 0	0.08	0.25	0.485	0.79	1.0
Y - 0	0.23	0.514	0.730	0.904	1.0

- Q5)** a) 1000 kg/hr of nicotine in water solution containing 1% nicotine is to be extracted with kerosene at 20°C. Kerosene counter currently to reduce nicotine concentration to 0.1%. How many theoretical stages are required? Use equilibrium data is **[5]**

X = 0	0.001011	0.00246	0.00502	0.00751	0.00998	0.0102
Y = 0	0.000807	0.001961	0.00456	0.00686	0.00913	0.00935

Where

$$Y = \text{kg nicotine} / \text{kg kerosene}$$

$$X = \text{kg nicotine} / \text{kg water}$$

- b) Explain the selection criteria for solvent for liquid liquid extraction. **[2]**  
 c) Discuss in brief about use of triangular diagram. **[3]**

OR

**Q6)** 1000 kg of pyridine - water solution containing 50% pyridine is to be extracted with equal amount of pure chlorobenzene. The raffinate from the first extraction is to be extracted with a weight of solvent equal to raffinate weight and so on ( $S_2=R_1$ ,  $S_3=R_2$ ). What is the exit concentration and percentage recovery of pyridine after three stages? The equilibrium data and tie line data is as given below. **[10]**

Chlorobenzene Layer (C.B.)			Water Layer		
Pyridine	C.B.	Water	Pyridine	C.B.	Water
0.0	99.95	0.05	0	0.08	99.92
11.05	88.28	0.67	5.02	0.16	94.82
18.95	79.90	1.15	11.05	0.24	88.71
24.10	74.28	1.62	18.90	0.38	80.72
28.60	69.15	2.25	25.50	0.58	73.92
31.55	65.58	2.87	36.10	1.85	62.05
35.05	61.00	3.95	44.95	4.18	50.81
40.60	53.00	6.40	53.20	8.50	37.90
49.00	37.8	13.2	49.00	37.8	13.20



Total No. of Questions : 6]

SEAT No. :

**P3655**

[Total No. of Pages : 1

**APR - 15 / Engg. - 140**

**T.E. (Chemical) (In Sem - Semester - II)**

**PROCESS INSTRUMENTATION AND CONTROL**

**(2012 Pattern)**

*Time : 1 Hour]*

*[Max. Marks : 30*

*Instructions to the candidates:*

- 1) *Figures to the right indicate full marks.*
- 2) *Your are advised to attempt not more than 3 questions.*
- 3) *Your answers will be valued as a whole.*
- 4) *Use of logarithmic tables slide rule, Mollier charts, electronic pocket calculator and steam tables is allowed.*
- 5) *Assume suitable data if necessary.*

**Q1)** Define Instrumentation and classify the Instruments Based on function. **[10]**

OR

**Q2)** Explain Static and Dynamic characteristics of a measuring instruments. Give a suitable example. **[10]**

**Q3)** a) Explain the working of the mercury glass thermometer with the help of neat diagram. **[5]**

b) Evaluate the temperature at which Fahrenheit and centigrade scales coincide. **[5]**

OR

**Q 4)** a) Explain RTD with neat diagram. **[5]**

b) Explain optical pyrometer with neat diagram. **[5]**

**Q5)** a) Enlist various pressure measuring instruments and explain U - tube manometer in detail. **[5]**

b) Enumerate the desirable characteristics of manometric liquids. **[5]**

OR

**Q6)** a) Explain Bourdon pressure gauge. **[5]**

b) Explain LVDT as pressure measuring device. **[5]**



Total No. of Questions : 6]

SEAT No. :

**P3656**

[Total No. of Pages : 2

**APR - 15 / Engg. - 141**

**T.E. (Computer Engineering) (In Sem - Semester - II)**  
**PRINCIPLES OF CONCURRENT AND DISTRIBUTED**  
**PROGRAMMING**  
**(2012 Pattern)**

*Time : 1 Hour]*

*[Max. Marks : 30*

*Instructions to the candidates:*

- 1) *Answer Q.1 or Q.2, Q.3 or Q.4, Q.5 or Q.6.*
- 2) *Neat diagrams must be drawn wherever necessary.*
- 3) *Figures to the right indicate full marks.*
- 4) *Assume suitable data if necessary.*

- Q1)** a) Explain declarative computation model with suitable example. [4]  
b) Discuss the features and applications of Lisp. [4]  
c) Explain the following methods with respect to MPI Java : - [2]  
i) MPI. COMM\_WORLD. Send ( )  
ii) MPI. COMM\_WORLD. Receive ( ).

OR

- Q2)** a) Explain Open CL Programming environment tool for concurrent programming. [4]  
b) Explain the following with respect to declarative computational model. [4]  
i) The single assignment store.  
ii) Data flow variables.  
iii) Declarative variables.  
iv) Value store.  
c) What will be the output of following with respect to LISP. [2]  
i) (CAR (CDR (CDR' (P Q R S T ))))  
ii) (CDR (CAR' (' (P Q) R )))

**P.T.O.**



- Q3)** a) What are different types of dependencies. Explain with suitable example. [4]
- b) What Java interface must be implemented by all threads for multithreading in concurrent Java? Illustrate with suitable example. [3]
- c) Write a short note on concurrent grammar. [3]

OR

- Q4)** a) What is process migration? Explain the major steps in process migration and enlist desirable features of a good process migration. [4]
- b) Explain how global data, variables are used for Interthread communication with an example. [3]
- c) Write a short note on multithreading using Concurrent Lisp. [3]

- Q5)** a) What is CUDA? Draw a diagram showing the details of CUDA hardware. [4]
- b) Explain how the performance analysis of parallel algorithm is done. [4]
- c) List the various types of parallel architecture and architectural classification scheme. [2]

OR

- Q6)** a) What is synchronization? Describe suitable example of use of synchronization with respect to concurrent Java. [4]
- b) What are the properties of object oriented programming model? Explain with suitable example. [4]
- c) What is semaphore? Explain how concurrency is achieved with semaphore. [2]



Total No. of Questions : 6]

SEAT No. :

**P3657**

[Total No. of Pages : 2

**APR - 15 / Engg. - 142**

**T.E. (Computer Engg.) (In Sem - Semester - II)**

**EMBEDDED OPERATING SYSTEMS**

**(2012 Pattern) (Theory)**

*Time : 1 Hour]*

*[Max. Marks : 30*

*Instructions to the candidates:*

- 1) *Answer Q.1 or Q.2, Q.3 or Q.4, Q.5 or Q.6.*
- 2) *Neat diagrams must be drawn wherever necessary.*
- 3) *Figures to the right indicate full marks.*
- 4) *Assume Suitable data if necessary.*

- Q1)** a) Differentiate Hard, soft and firm real time systems. State one example of each. **[4]**
- b) What are the layers of an operating system. Explain with diagram. **[3]**
- c) Differentiate periodic, aperiodic and sporadic tasks. **[3]**

OR

- Q2)** a) What are the qualities of good RTOS? **[4]**
- b) Explain with example deadline scheduling and rate monotonic scheduling. **[6]**

- Q3)** a) What are the seven operating modes of ARM? Describe each one of them in short. **[4]**
- b) Differentiate RISC Vs CISC. **[2]**
- c) Explain ARM- SOC core with peripherals. **[4]**

OR

- Q4)** a) Explain bit configuration of CPSR of ARM **[3]**
- b) Explain the features of BBB revision C with the help of neat diagram. **[4]**
- c) Explain multiple Load/Store instructions with example. **[3]**

**P.T.O.**

- Q5)** a) Differentiate between BIOS and Boot loader. [2]  
b) What is Embedded System? Draw and explain anatomy of embedded system. [4]  
c) Give the steps involved in composite kernel image construction. [4]

OR

- Q6)** a) Define following terms with reference to RTOS. [3]  
i) Release Time  
ii) Completion Time  
iii) Dead line  
b) Compare Standalone processor with Integrated Processor. [3]  
c) Write any four features of ARM Cortex-M3. [4]



Total No. of Questions : 6]

SEAT No. :

**P3658**

[Total No. of Pages : 2

**APR - 15 / Engg. - 143**

**T.E. (Computer Engg.) (In Sem - Semester - II)**

**COMPUTER NETWORKS**

**(2012 Pattern)**

*Time : 1 Hour]*

*[Max. Marks : 30*

*Instructions to the candidates:*

- 1) *Answer Q.1 or Q.2, Q.3 or Q.4, Q.5 or Q.6.*
- 2) *Neat diagrams must be drawn wherever necessary.*
- 3) *Figures to the right indicate full marks.*
- 4) *Assume suitable data, if necessary.*

**Q1)** a) What is the difference between persistent & non persistent HTTP? Also explain HTTP message format. **[6]**

b) Compare IMAP and POP3. **[4]**

OR

**Q2)** a) Compare file transfer using SMTP & HTTP. **[7]**

b) State which transport layer protocol is used by following application layer protocol. **[3]**

HTTP, FTP, DHCP, DNS, SMTP, TELNET.

**Q3)** a) What is QOS? Explain various parameters for QOS in a network. **[6]**

b) List TCP congestion control approaches. Explain any one. **[4]**

OR

**Q4)** a) Explain in detail RTP with packet header format. **[7]**

b) Draw TCP Header format. **[3]**

**P.T.O.**

- Q5)** a) Explain Distance Vector Routing. What are the advantage & disadvantage of DV Routing? [6]
- b) Draw & explain IPv4 Header. [4]

OR

- Q6)** a) Divide the network 220.125.5.192/26 into 8 subnetworks. How many hosts can be connected in each network? Show their IP range, network address and broadcast address. [6]
- b) Describe in short the importance & working of following commands.[4]
- |                 |               |
|-----------------|---------------|
| i) Ping         | ii) IP config |
| iii) Traceroute | iv) Netstat   |



Total No. of Questions : 6]

SEAT No. :

**P3659**

[Total No. of Pages : 2

**APR - 15 / Engg. - 144**

**T.E. (Computer Engineering) (In Sem - Semester - II)**

**SOFTWARE ENGINEERING**

**(2012 Pattern)**

*Time : 1 Hour]*

*[Max. Marks : 30*

*Instructions to the candidates:*

- 1) *All questions are compulsory.*
- 2) *Neat diagrams must be drawn wherever necessary.*
- 3) *Figures to the right indicate full marks.*
- 4) *Assume Suitable data, if necessary.*

- Q1)** a) What are the various umbrella activities applied throughout a software project? [6]
- b) What are different software myths that the customers and practitioners believe in and what are their corresponding realities? [4]

OR

- Q2)** a) Explain Cleanroom process. What are the different key strategies used for Cleanroom approach to software development? [6]
- b) Explain the concept of Software Evolution. Explain the merits and demerits of Agile process model. [4]

- Q3)** a) Explain four desirable components of a good Software Requirements Specification (SRS) document. [6]
- b) What do you mean by requirement negotiation and validation? [4]

OR

- Q4)** a) Explain Scenario Based modeling with suitable example. [6]
- b) What are functional and non functional requirements of software. [4]

**P.T.O.**

- Q5)** a) Explain about the various design concepts considered during design?[6]  
b) Justify “A cohesive design should have high cohesiveness and low coupling”. [4]

OR

- Q6)** a) Explain in detail, the need of ATAM (Architecture Tradeoff Analysis Method) and its steps. [6]  
b) Compare the Data Flow and Data Centred Architecture. [4]



Total No. of Questions : 6]

SEAT No. :

**P3660**

[Total No. of Pages : 2

**APR - 15 / Engg. - 145**

**T.E. (Computer Engineering) (In Sem - Semester - II)**

**DIGITAL SIGNAL PROCESSING APPLICATIONS**

**(2012 Pattern)**

*Time : 1 Hour]*

*[Max. Marks : 30*

*Instructions to the candidates:*

- 1) *Attempt Q.1 or Q.2, Q.3 or Q.4, Q.5 or Q.6.*
- 2) *Neat diagrams must be drawn wherever necessary.*
- 3) *Figures to the right indicate full marks.*
- 4) *Assume suitable data, if necessary.*

**Q1)** a) Why the problem of aliasing is observed during the sampling process? Derive the relationship between analog frequency  $F$  and DT frequency  $f$ . **[5]**

b) State the advantages of Digital Signal Processing and give the classification of DT signals. **[5]**

OR

**Q2)** a) Define the impulse response of a system and obtain it for a system described as **[5]**

$$y(n) = x(n) + 0.5 y(n-1)$$

b) Represent a DT sequence  $x(n)$  using convolution. Obtain the computational complexity of linear convolution of two DT signals having  $N$  samples each. **[5]**

**Q3)** a) State and prove : **[5]**

- i) time reversal and
- ii) time shifting property of a FT.

b) State the necessary condition for the existence of FT. Explain how the magnitude response of a FT is obtained? Obtain DT frequencies  $\{\omega_k\}$  for 8-point DFT. **[5]**

OR

**P.T.O.**



- Q4)** a) Obtain 4 point DFT for a sequence  $x(n) = \{1, -2, 2, 1\}$  and plot the magnitude spectrum. [5]
- b) Discuss the periodicity and circular shifting property of N point DFT. How convolution property of DFT is different than FT? [5]

- Q5)** a) Obtain ZT of a DT signal using ZT properties where, [5]  
 $x(n) = 2^n \cdot u(n-1)$
- b) Derive the relationship between ZT and FT. [5]

OR

- Q6)** a) Obtain ZT of two standard signals  $u(n)$  and  $\delta(n)$ . Plot its ROCs. [5]
- b) Define a system function  $H(Z)$ . How it describes the properties of DT system? What is pole zero plot? [5]



Total No. of Questions : 6]

SEAT No. :

[Total No. of Pages : 2

**P3661**

**APR - 15 / Engg. - 146**

**T.E. INFORMATION TECHNOLOGY (In Sem - Semester - II)**

**Design & Analysis of Algorithms**

**(2012 Pattern)**

*Time : 1 Hour]*

*[Max. Marks : 30*

*Instructions to the candidates:*

- 1) *Answer Q.1 or Q.2, Q.3 or Q.4, Q.5 or Q.6.*
- 2) *Neat diagrams must be drawn wherever necessary.*
- 3) *Figures to the right side indicate full marks.*
- 4) *Assume suitable data if necessary.*

- Q1)** a) Define best-case, worst-case and average-case efficiency. Is average-case efficiency is an average of best-case and worst-case efficiencies? [5]
- b) State tiling problem and prove it by mathematical induction. [5]

OR

- Q2)** a) With the help of example, explain general strategy for analyzing time efficiency of non-recursive algorithm. [5]
- b) Solve following recurrence relation using backward substitution method. [5]

$$T(n) = T(n-1) + 1$$

$$T(0) = 0$$

- Q3)** a) Explain the concept of divide and conquer technique. Write Master theorem. [5]
- b) Give recurrence relation for binary search and solve the same. [5]

OR

**P.T.O.**

- Q4)** a) What is Huffman code? [2]  
 b) Construct Huffman tree for following data and obtain its Huffman code. [8]

Character	A	B	C	D	E	F
Frequency	0.5	0.35	0.5	0.1	0.4	0.2

- Q5)** a) What is travelling salesperson problem? How it can be solved by dynamic programming strategy? [5]  
 b) Apply the bottom-up dynamic programming algorithm to the following instance of the knapsack problem where capacity of knapsack i.e.  $W = 5$  [5]

Item	Weight	Value
1	2	12
2	1	10
3	3	20
4	2	15

OR

- Q6)** a) What is optimal binary search tree? [2]  
 b) Let  $N=3$ , and  $\{a_1, a_2, a_3\} = \{\text{do, if, while}\}$ . Let  $p(1:3) = \{0.5, 0.1, 0.05\}$  and  $q(0:3) = \{0.15, 0.1, 0.05, 0.05\}$ . Compute and construct OBST for above value using Dynamic Programming. [8]



Total No. of Questions : 6]

SEAT No. :

[Total No. of Pages : 2

**P3662**

**APR - 15 / Engg. - 147**  
**T.E. (IT) (In Sem - Semester - II)**  
**SYSTEMS PROGRAMMING**  
**(2012 Pattern)**

*Time : 1 Hour]*

*[Max. Marks : 30*

*Instructions to the candidates:*

- 1) *Answer Q.1 or Q.2, Q.3 or Q.4, Q.5 or Q.6.*
- 2) *Neat diagrams must be drawn wherever necessary.*
- 3) *Figures to the right indicate full marks.*
- 4) *Assume suitable data, if necessary.*

**Unit - I**

**Q1) a) Design a macroprocessor? Explain Nested Macro Call. [6]**

b) Show content of symbol table at the end of pass I and generate intermediate code. [4]

	START	100
A	DS	3
L1	MOVER	AREG,B
	ADD	AREG,C
	MOVEM	AREG,D
D	EQU	A+1
L2	PRINT	D
	ORIGIN	A-1
C	DC	'5'
	ORIGIN	L2+4
	STOP	
B	DC	'19'
	END	L1

OR

**P.T.O.**

- Q2)** a) Explain data structures of 2 pass assembler. [6]  
b) What is language processor explains with diagram. [4]

**Unit - II**

- Q3)** a) What are the types of cards used in direct linking loader? Explain with example. [6]  
b) Differentiate between absolute loader & relocatable loader. [4]

OR

- Q4)** a) Explain the concept of overlay with example. [4]  
b) Explain compile and Go Loader scheme with its advantages and disadvantages. [6]

**Unit - III**

- Q5)** a) Write short note on LEX. [4]  
b) Explain first three phases of compiler for given example (b2-4ac)/2a [6]

OR

- Q6)** a) Give regular expression/ definition for while space identifier and simple integer constant. Explain how they are used in recognizing the corresponding tokens. Support your answer with transition diagram. [4]  
b) Convert RE to DFA for (a/b)\*abb. [6]



Total No. of Questions : 6]

SEAT No. :

**P3664**

[Total No. of Pages : 2

**APR-15/ENGG.-149**

**T.E. (Information Technology) (In Sem - Semester - II)**

**MULTIMEDIA TECHNOLOGIES**

**(2012 Pattern)**

*Time : 1 hr. 30 Min.]*

*[Max. Marks : 30*

*Instructions to the candidates:*

- 1) *Solve Q1 or Q2, Q3 or Q4, Q5 or Q6.*
- 2) *Neat diagram must be drawn wherever necessary.*
- 3) *Figures to the right indicates full marks.*
- 4) *Assume suitable data, if necessary.*

**Q1)** a) What is Authoring Tool? Which authoring tools are most suited for web-based application and e-learning? **[5]**

b) A document contains letters A through F with frequencies as shown in table. **[5]**

Symbol	Frequency
A	0.25
B	0.1
C	0.2
D	0.15
E	0.26
F	0.04

Use Huffman coding to derive codeword set.

OR

**Q2)** a) Explain different building blocks of Multimedia. **[5]**

b) What are the features, requirements and issues related to multimedia databases? **[5]**

**P.T.O.**

- Q3)** a) What is the need of compression? List the parameters to measure compression. [4]
- b) Draw and explain the JPEG encoding and decoding in brief. [6]

OR

- Q4)** a) What is the need of image enhancement? Explain any one image enhancement technique. [5]
- b) What is bitmap? Explain BITMAPFILEHEADER of BMP file. [5]

- Q5)** a) What is sound wave? What are the characteristics of sound wave? [5]
- b) State different audio file formats which supports Android OS. Explain any one briefly. [5]

OR

- Q6)** a) What is MIDI? In relation to MIDI, distinguish between channel messages and system messages giving examples. [5]
- b) What are various audio compression techniques? Explain any one in brief. [5]



Total No. of Questions : 6]

SEAT No. :

P893

[Total No. of Pages : 2

APR - 15 / In. SPL - 1

T.E. (Civil) (In Sem.) (Semester - I)

**HYDROLOGY AND WATER RESOURCE ENGINEERING  
(2012 Pattern)**

*Time : 1 Hour]*

*[Max. Marks :30*

*Instructions to the candidates :*

- 1) *Answer Q1 or Q2, Q3 or Q4, Q5 or Q6.*
- 2) *Neat diagrams must be drawn wherever necessary.*
- 3) *Figures to the right side indicate full marks.*
- 4) *Assume suitable data if necessary.*

**UNIT - I**

- Q1)** a) Explain stream flow measurement by area-velocity method. [6]
- b) The normal annual precipitation of five raingauge stations P, Q, R, S, and T are respectively 125, 102, 76, 113 and 137 cm. During a particular storm the precipitation recorded by stations P, Q, R, and S are 13.2, 9.2, 6.8 and 10.2 cm respectively. The instrument at station T was inoperative during that storm. Estimate the rainfall at station T during that storm.[4]

OR

- Q2)** a) A 6 hr storm produced rainfall intensities of 7, 18, 25, 12, 10 and 3 mm/h in successive one hour intervals over a basin of 800 sq km. The resulting runoff is observed to be 2640 ha-m. Determine  $\Phi$ -index for the basin. [6]
- b) Draw neat sketch of hydrologic cycle showing all components and define throughfall. [4]

P.T.O.



## UNIT - II

- Q3)** a) Define : **[4]**
- i) duty ii) cumec day
  - iii) kor depth iv) paleo irrigation
- b) Find the frequency of irrigation if **[6]**
- i) Field capacity of soil is = 29 %
  - ii) Permanent wilting point = 15 %
  - iii) Density of soil is = 1300 kg/m<sup>3</sup>
  - iv) Effective depth of root zone = 75 cm
  - v) Daily consumptive use of water for the given crop = 14 mm
  - vi) Readily available moisture = 75 % of available moisture

OR

- Q4)** a) Explain drip irrigation with a neat layout sketch. **[5]**
- b) List various methods of assessing canal revenue. Explain volumetric basis method with merits and demerits. **[5]**

## UNIT - III

- Q5)** a) Define : **[2]**
- i) Specific yield ii) Specific retention
- b) Derive Thiem's formula for confined aquifer. State the assumption made. **[8]**

OR

- Q6)** a) A 20 cm diameter well is sunk fully in an unconfined aquifer whose saturated thickness is 20 m. The coefficient of permeability is 0.005 m/s. At a steady state flow condition the drawdown is 5 m at well face and its radius of influence is 200 m. Calculate the steady state discharge of the well. **[4]**
- b) Enlist different types of tube wells and dug wells and explain strainer type with a neat sketch. **[6]**



**P905**

**APR - 15/In. SPL - 13**  
**T.E. (Civil) (In Sem.) (Semester - I)**  
**Fluid Mechanics - II**  
**(2012 Pattern)**

*Time : 1 Hour]*

*[Max. Marks : 30*

*Instructions to the candidates:*

- 1) Answer Q.1 or Q.2, Q.3 or Q.4, Q5. or Q6.*
- 2) Neat diagrams must be drawn wherever necessary.*
- 3) Figures to the right side indicate full marks.*
- 4) Assume suitable data if necessary.*

**Unit - I**

- Q1) a)** Experiments were conducted in wind tunnel with a wind speed of 51 km/hr on a flat plate of size 2.1m long and 1.1m wide. The density of air is  $1.15 \text{ kg/m}^3$ . The coefficient of lift and drag are 0.76 and 0.16 respectively. Determine : **[5]**
- i) the lift force.
  - ii) the drag force.
  - iii) the resultant force.
  - iv) direction of resultant force and
  - v) power exerted by air on plate.
- b)** Explain in brief: **[5]**
- i) Water hammer phenomenon in pipes and
  - ii) Types of unsteady flow.

OR

- Q2) a)** Discuss in brief: **[6]**
- i) Magnus effect and
  - ii) Polar diagram.

**P.T.O.**

- b) A valve is provided at the end of a cast iron pipe of diameter 160 mm and of thickness 12mm. The water is flowing through the pipe, which is suddenly stopped by closing the valve. Find the maximum velocity of water, when the rise of pressure due to sudden closure of valve is  $198.2 \text{ N/cm}^2$ . Take  $K$  for water as  $19.62 \times 10^4 \text{ N/cm}^2$  and  $E$  for the cast iron pipe as  $11.772 \times 10^6 \text{ N/cm}^2$ . [4]

### Unit - II

**Q3)** a) Explain in brief “classification of channel” with neat sketches. [4]

- b) The rectangular channel of width 9m, carries discharge of  $16 \text{ m}^3/\text{s}$  with the depth of flow of water is 1.3 m.

Calculate: [6]

- i) Specific energy of flowing water.
- ii) Critical depth.
- iii) Critical velocity.
- iv) Value of minimum specific energy.
- v) The discharge per unit width.

OR

**Q4)** a) Water flows over rectangular weir 1.1m wide at a depth of 160mm and afterwards passes through a triangular right-angled weir. Taking  $C_d$  for the rectangular and triangular weir as 0.63 and 0.60 respectively, find the depth over triangular weir. [4]

b) Explain in brief the following: [6]

- i) Specific Energy Curve and
- ii) Channel Transitions.

### Unit - III

- Q5) a)** Define the following terms: [5]
- i) Normal depth.
  - ii) Conveyance.
  - iii) Section Factor.
  - iv) Most Economical Channel.
  - v) Hydraulic Mean Depth.
- b) The depth of flow of water, at a certain section of a rectangular channel of 2.1m wide is 0.35m. The discharge through the channel is  $1.6 \text{ m}^3/\text{s}$ . Determine whether a hydraulic jump will occur, and if so, find its height and loss of energy per kg of water [5]

OR

- Q6) a)** Prove that for most economical trapezoidal channel section; half of top width equal to one of sloping side of the channel. [5]
- b) Derive the expression for loss of energy due to hydraulic jump with usual notations. [5]





Total No. of Questions : 6]

[Total No. of Pages : 2

**P906**

**APR - 15/In. SPL/14**

**T.E. (Mechanical) (Semester - I)**

**HYDRAULICS AND PNEUMATICS**

**(2012 Pattern) (In Sem.)**

*Time : 1 Hour]*

*[Max. Marks : 30*

*Instructions to the candidates:*

- 1) Answer 3 questions.*
- 2) Neat diagrams must be drawn wherever necessary.*
- 3) Figures to the right indicate full marks.*
- 4) Use of electronic pocket calculator is allowed.*
- 5) Assume suitable data, if necessary.*

**Q1) a)** State advantages and limitations of Hydraulics and Pneumatics system with Mechanical System. **[5]**

b) Classify Hydraulic Fluids & explain any four important properties. **[5]**

OR

**Q2) a)** Explain any four fields of application of Fluid Power system with suitable example. **[5]**

b) Explain Pascal's law with hydraulics jack. **[5]**

**Q3) a)** What are the different applications of accumulators? Explain any one with the help of a circuit. **[5]**

b) A pump has a displacement volume of 88.4 cc. It delivers 0.00150 m<sup>3</sup>/s at 1100 RPM and 75 bar. **[5]**

If the prime mover input torque is 124.5 N-m, find

- i) Overall Efficiency.
- ii) Theoretical Torque required to operate Pump.

OR

**P.T.O.**

- Q4) a)** Explain with neat sketch any one axial piston pump. [5]
- b) A  $N_2$ -gas charged accumulator supplies energy to a system with 15 liters of oil within the range of 125 bar (abs) to 175 bar (abs). If the accumulator has pre-charged pressure of 90bar (abs). Size the accumulator for [5]
- Isothermal,
  - Adiabatic pressures.

- Q5) a)** Classify linear actuators & explain construction of double acting cylinder with neat sketch. [5]
- b) A mass of 2500 kg is to be accelerated horizontally up to velocity 1.1 m/s from rest over distance of 60 mm using double acting cylinder. The coefficient of friction between the load and guide is 0.2. Calculate the bore of the cylinder required to accelerate the load if the maximum allowable pressure at cap end side is 120 bar. Assume the back pressure at rod end side of the cylinder as zero and seal friction to be equivalent to a pressure drop of 6 bar. [5]

OR

- Q6) a)** Classify rotary actuators and define various efficiencies of hydraulic motor. [5]
- b) A hydrostatic transmission operating at 70 bar has the following characteristics: [5]

PUMP	MOTOR
$V_D = 92 \text{ cm}^3$	$V_D = ?$
$\eta_v = 85\%$	$\eta_v = 91\%$
$\eta_m = 89\%$	$\eta_m = 90\%$
$N = 600 \text{ rpm}$	$N = 500 \text{ rpm}$

- Find :
- Displacement of motor.
  - Motor output torque.



**P907**

**APR - 15/In. SPL/15**

**T.E. (Computer Engineering) (Special) (In Semester)**

**Computer Forensic & Cyber Applications**

*Time : 1 Hour]*

*[Max. Marks : 30*

*Instructions to the candidates:*

- 1) Solve any 3 questions from (Q.1 or Q.2) and (Q.3 or Q.4) and (Q.5 or Q.6).*
- 2) Figures to the right indicate full marks.*
- 3) Assume suitable data, if any.*

- Q1)** a) Explain Protocol and Standard in Networking. [4]  
b) What is OSI Model? Explain in detail. [4]  
c) Explain TCP/IP model with diagram. [2]

OR

- Q2)** a) What are different network topologies? [4]  
b) Why Switching is used? [4]  
c) Importance of hub in networking. [2]

- Q3)** a) What is Digital Forensics? Explain in detail. [4]  
b) Write short note on Language of computer crime investigation. [4]  
c) How to produce digital evidence in court room? [2]

OR

- Q4)** a) Explain the importance of cyber crime law. [4]  
b) Explain the cyber crime law with US perspective. [4]  
c) How to handle digital crime scene? [2]

**P.T.O.**



- Q5)** a) Explain digital evidence as alibi. [6]  
b) Explain Gender offender on internet. [4]

OR

- Q6)** a) What is Computer Intrusion in networking? [4]  
b) Explain Violent Crime. [4]  
c) Explain Gender offender on internet. [2]



Total No. of Questions : 6]

SEAT No. :

P894

[Total No. of Pages : 2

APR - 15 / In. SPL - 2

TE (Mechanical) (In Sem.) (Semester - I)

DESIGN OF MACHINE ELEMENTS - I

(2012 Pattern)

*Time : 1 Hour]*

*[Max. Marks :30*

*Instructions to the candidates :*

- 1) *Answer Q1 or Q2, Q3 or Q4, Q5 or Q6.*
- 2) *Neat diagrams must be drawn wherever necessary.*
- 3) *Figures to the right indicate full marks.*
- 4) *Assume suitable data if necessary.*

**UNIT - I**

- Q1)** a) Derive an expression for bending stress in the cotter of a cotter joint? [4]  
b) Define factor of safety? Explain the factors to be considered while selecting the factor of safety. [6]

OR

- Q2)** A foot lever is 900 mm from the centre of shaft to the point of application of 800 N load. Find i) Diameter of the shaft, and ii) Dimensions of rectangular arm of the foot lever at 100 mm from the centre of shaft assuming width of the arm as 3 times thickness. The allowable tensile stress may be taken as 80 N/mm<sup>2</sup> and allowable shear stress 65 N/mm<sup>2</sup>. [10]

**UNIT - II**

- Q3)** a) What is torsional and lateral rigidity of shaft? State the applications where rigidity is the design criteria. [4]  
b) Classify the coupling and give the difference between flange and flexible coupling. [6]

OR

**P.T.O.**

**Q4)** A shaft supported between two bearings 750 mm apart, receives 12.5 KW power at 300 rpm through a coupling located to the left of left hand bearing. It transmits the power to a belt pulley of weight 300N and diameter 450 mm, which is located at a distance of 200 mm to the right of right hand bearing. The ratio of belt tension of tight and slack side is 2:1. The belt tension acts in vertically downward direction. The shaft material has yield strength of 300 N/mm<sup>2</sup> and an ultimate tensile strength of 550 N/mm<sup>2</sup>. **[10]**

The combined shock and fatigue factor for bending and torsion are 1.5 and 1.0 respectively. Determine:

- i) The shaft diameter using ASME code.
- ii) The various stresses in a rectangular key, if key selected has 12 mm width, 10 mm height and 60 mm length.

### UNIT - III

**Q5) a)** Draw the following diagrams and write their equations. **[4]**

- i) Goodman diagram
- ii) Soderberg diagram

b) What is stress concentration? What are the causes of stress concentration? Explain any two methods to reduce stress concentration. **[6]**

OR

**Q6)** The work cycle of a shaft subjected to completely reverse bending stresses consists of the following three elements : **[10]**

- i)  $\pm 350$  N/mm<sup>2</sup> for 35 % of time,
- ii)  $\pm 400$  N/mm<sup>2</sup> for 40 % of time, and
- iii)  $\pm 500$  N/mm<sup>2</sup> for remaining time.

The material for shaft is 50C4 ( $S_{ut} = 660$ N/mm<sup>2</sup>). There is no stress concentration. The diameter of shaft is 6 mm. Assume following data: Surface finish factor = 1, Reliability factor = 0.8485 ,Size factor 0.85. Determine the life of component.



Total No. of Questions : 6]

SEAT No. :

P895

[Total No. of Pages : 2

APR - 15 / In. SPL - 3

T.E. (Computer) (In Sem.) (Semester - I)

THEORY OF COMPUTATION

(2012 Pattern)

Time : 1 Hour]

[Max. Marks :30

Instructions to the candidates :

- 1) Answer Q1 or Q2, Q3 or Q4, Q5 or Q6.
- 2) Neat diagrams must be drawn wherever necessary.
- 3) Figures to the right side indicate full marks.
- 4) Assume suitable data if necessary.

UNIT - I

- Q1)** a) Design FA to check, whether given unary number is divisible by three. [4]
- b) Is NFA more powerful than DFA? Justify. [2]
- c) Define : [4]
- i) Symbol
  - ii) String.
  - iii)  $L^*$  and  $L^+$

OR

- Q2)** a) Write regular expressions for each of the following languages : [6]
- i) For  $\Sigma = \{a, b\}$ , set of all strings with no consecutive 'a's and 'b's.
  - ii) For  $\Sigma = \{0, 1\}$ , set of all strings in which every 0 is immediately followed by at least two 1's
  - iii)  $L = \{1^{(2n+1)} \mid n \geq 1\}$
- b) Construct DFA to accept a language L over input set  $\{a, b\}$  and consisting of strings that always begins with "aa". [4]

P.T.O.

## UNIT - II

- Q3)** a) Design Mealy machine to find 2's complement of a given binary number. [6]  
b) Construct NFA without  $\epsilon$  moves from given NFA with  $\epsilon$  moves. [4]

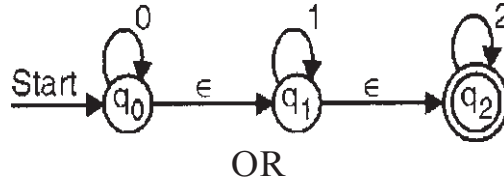

OR

- Q4)** a) Show that language  $L = \{ a^p / p \text{ is prime number} \}$  is not regular. [6]  
b) State applications for Regular Expressions. [4]

## UNIT - III

- Q5)** a) Convert the following right-linear grammar to its equivalent left-linear form. [6]

$$S \rightarrow 0A \mid 1B$$

$$A \rightarrow 0C \mid 1A \mid 0$$

$$B \rightarrow 1B \mid 1A \mid 1$$

$$C \rightarrow 0 \mid 0A$$

- b) Write Left Most and Right Most derivation for the string "aaabbabbba" using following grammar. [4]

$$S \rightarrow aB \mid bA$$

$$A \rightarrow a \mid aS \mid bAA$$

$$B \rightarrow b \mid bS \mid aBB$$

OR

- Q6)** a) Convert the following grammar to Chomsky Normal form (CNF) [6]

$$S \rightarrow aSa \mid bSb \mid a \mid b \mid aa \mid bb$$

$$S \rightarrow ABA$$

$$A \rightarrow aA \mid \epsilon$$

$$B \rightarrow bB \mid \epsilon$$

- b) Give context free grammars for the following languages [4]

i)  $L = \{ x \mid x \in \{a, b\}^* \text{ with strings of starting with 'b' and ending in 'a'} \}$

ii)  $L = \{ x \mid x \in \{a, b\}^* \text{ with strings of odd length palindrome} \}$



Total No. of Questions : 6]

SEAT No. :

P896

[Total No. of Pages : 2

**APR - 15 / In. SPL - 4**  
**T.E. (Civil) (In Sem.) (Semester - I)**  
**INFRASTRUCTURE ENGINEERING**  
**(2012 Pattern)**

*Time : 1 Hour]*

*[Max. Marks :30*

*Instructions to the candidates :*

- 1) Answer Q1 or Q2, Q3 or Q4, Q5 or Q6.*
- 2) Neat diagrams must be drawn wherever necessary.*
- 3) Figures to the right side indicate full marks.*
- 4) Assume suitable data if necessary.*

**UNIT - I**

- Q1)* a) Enlist various sectors of infrastructure. Explain in brief any one sector. [5]
- b) Discuss the merits and demerits of mechanized construction operations. [5]

OR

- Q2)* a) Write note on public private partnership. [5]
- b) Discuss METRO – a new approach in public transport. [5]

**UNIT - II**

- Q3)* a) What do you understand by Feasibility study? For construction of a new railway line, what are the feasibility studies that have to be undertaken? [5]
- b) Enlist various types of rail joints. Explain one of them with neat sketch. [5]

OR

**P.T.O.**

- Q4)** a) What do you understand by welding of rails? State merits and demerits of welding of rails. [5]
- b) What are the requirements of an ideal sleeper. [5]

### UNIT - III

- Q5)** a) With the help of neat labeled sketch, explain the electro osmosis dewatering. [5]
- b) Differentiate between tunnel formwork and slip form. [5]

OR

- Q6)** a) Explain the selection criteria for cranes. With a neat labeled sketch explain in brief boom placers. [5]
- b) With the help of neat labeled sketch explain pneumatic dredging. [5]



Total No. of Questions : 6]

SEAT No. :

P897

[Total No. of Pages : 2

APR - 15 / In. SPL - 5

T.E. (Mechanical) (In sem.) (Semester - I)

HEAT TRANSFER

(2012 Pattern)

Time : 1 Hour]

[Max. Marks :30

Instructions to the candidates :

- 1) Solve Q.1 or Q.2, Q.3 or Q.4 and Q.5 or Q.6.
- 2) Draw neat diagrams wherever necessary.
- 3) Use of scientific calculator is allowed.
- 4) Assume suitable data wherever necessary.
- 5) Figures to the right indicate full marks.

**Q1)** a) Derive three dimensional heat conduction equation in Cartesian coordinates. [6]

b) A steel pipe ( $k=50$  W/mK) of 100 mm I.D and 110 mm O.D is to be covered with two layers of insulation each having thickness of 50 mm. The thermal conductivity of first insulation material is 0.06 W/mK and that of the second is 0.12 W/mK. Estimate heat loss per meter length of pipe when temperature of inside tube surface is 523 K and that of surface is 323 K. [4]

OR

**Q2)** a) Prove that critical radius of insulation for sphere is given by  $r_c = 2k/h$  where  $k$  is conductivity of material and  $h$  is heat transfer coefficient. [6]

b) Will the rate of heat loss decrease if foam insulation ( $k= 0.09$  W/ m. K), is added to a 5 cm. outer diameter pipe carrying hot water? Take heat transfer coefficient on outer surface as  $10$  W/m<sup>2</sup> K. [4]

**Q3)** a) Derive an expression for maximum temperature in a plane slab having insulated surface on one side and convective heat transfer on the other side. The wall has conductivity  $k$  (W/ m. K) and uniform internal heat generation  $q$  (W/ m<sup>3</sup>). [6]

P.T.O.



- b) A plane wall of thickness 0.1m and  $k=25 \text{ W/mK}$ , having uniform volumetric heat generation of  $0.3 \text{ MW/m}^3$  is insulated on one side and is exposed to a fluid at  $92^\circ\text{C}$ . the convective heat transfer coefficient between the wall and the fluid is  $500 \text{ W/m}^2 \text{ K}$ . Determine : **[4]**
- Maximum temperature in the wall,
  - Draw temperature profile.

OR

- Q4)** a) Derive the following relation  $(T - T_\infty)/(T_0 - T_\infty) = e^{-(Bi Fo)}$  with usual notations. What is the criteria for validity of lumped system analysis?**[7]**
- b) Explain time constant and response of thermocouple. **[3]**

- Q5)** a) Define: Fin Efficiency & Effectiveness of Fins. **[3]**
- b) Derive an expression for temperature distribution of an infinitely long fin. **[7]**

OR

- Q6)** a) Derive an expression for fin efficiency of a fin with insulated tip. **[7]**
- b) What are extended surfaces? Why they are used? **[3]**



Total No. of Questions : 6]

SEAT No. :

P898

[Total No. of Pages : 2

APR - 15 / In. SPL - 6

T.E. (Computer Engg.) (In Sem.) (Semester - I)

OPERATING SYSTEMS DESIGN

(2012 Pattern)

*Time : 1 Hour]*

*[Max. Marks :30*

*Instructions to the candidates :*

- 1) *Answer Q1 or Q2, Q3 or Q4, Q5 or Q6.*
- 2) *Neat diagrams must be drawn wherever necessary.*
- 3) *Figures to the right side indicate full marks.*
- 4) *Assume suitable data if necessary.*

**Unit - I**

- Q1)** a) Explain in detail monolithic kernel and micro kernel. [6]  
b) Write short note on GRUB. [4]

OR

- Q2)** a) What is disk inode? Difference between disk inode and in-core inode?[6]  
b) What are system calls? Explain i) fork() ii) open() iii) exec(). [4]

**Unit - II**

- Q3)** a) Explain with neat diagram process states and transition. [8]  
b) Differentiate process and thread. [2]

OR

- Q4)** a) What is a process? Explain Context of Process. [6]  
b) Explain signal handling. [4]

P.T.O.

### Unit - III

- Q5)** a) What are the distinctions among logical, relative, and physical addresses? [6]
- b) Compare paging and segmentation. [4]

OR

- Q6)** a) Why is the principle of locality crucial to the use of virtual memory? Explain with example. [6]
- b) Write short notes on Linux memory management. [4]



**APR - 15 / In. SPL - 7**  
**T.E. (Civil) (In Sem.) (Semester - I)**  
**STRUCTURAL DESIGN - I**  
**(2012 Pattern)**

Time : 1½ Hours]

[Max. Marks :30

*Instructions to the candidates :*

- 1) Answer Q.1 or Q.2, Q.3 or Q.4 Q.5 or Q.6.
- 2) Neat sketches must be drawn wherever necessary.
- 3) Figures to the right indicate full marks.
- 4) Take Fe 410 grade of steel.
- 5) Take ultimate stress in bolt,  $f_{ub} = 400 \text{ N/mm}^2$ .
- 6) Assume suitable data if necessary.
- 7) Use of electronic pocket calculator. IS: 800-2007 and steel table allowed.
- 8) Use of cell phone is prohibited in the examination hall.

- Q1) a)** Draw stress distribution diagram for plastic, semi compact and slender section. Also classify ISHB 400 @ 77.4 kg/m and ISMC 400 @ 49.4 kg/m. **[5]**
- b)** A tension member of roof truss consists of 2 ISA 90 x 90 x 10 mm @ 13.4 kg/m connect to 10 mm thick gusset plate by fillet weld. Design welded connection assuming 5 mm weld size and draw the design sketch. **[5]**

OR

- Q2) a)** Determine the design tensile strength of the plate (250 mm x 8 mm) with the holes as shown in **Fig. 1b**, if the yield strength and the ultimate strength of the steel used are 250 MPa and 410 MPa and 20 mm diameter bolts are used. **[5]**

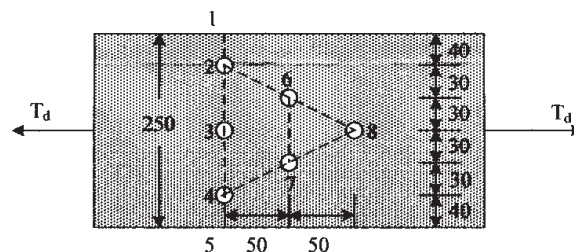
**Fig. 1 b**

- b) A tension member of roof truss consists of 2 ISA 90 x 90 x 12 mm @ 15.8 kg/m connect to 12 mm thick gusset plate by 5 bolt of 20 mm diameter. Determine design tensile strength due to rupture on net area. [5]

- Q3)** a) Determine the design strength of a column section ISLB 500 @ 75 kg/m with the effective length of the column as 5 m. Assume buckling axis as z-z axis and yield stress of steel  $f_y = 250$  MPa. [5]
- b) Differentiate lacing and battening in a built up column section on the basis of general and design consideration. [5]

OR

- Q4)** a) A built up column of length 10 m carries a factored load of 1100 kN. It consists of two channels ISMC 300 @ 35.8 kg/m back to back at a distance of 185 mm. The column is restrained in position but not in direction at both ends. Design the single lacing system of column. [5]
- b) A strut of truss consist of 2-ISA 80 x 80 x 8 mm @ 9.6 kg/m placed back to back on opposite side of gusset plate is to carry factored load of 275 kN. Design the bolted connection and draw design sketch. [5]

- Q5)** Design a slab base for the column consisting of ISMB 400 @ 61.6 kg/m carrying an axial factored load of 450 kN. Use M20 grade of concrete. [10]

OR

- Q6)** A column having effective length of 3.5 m is subjected to factored axial load of 450 kN and factored moment of 50 kNm. Design the column section. Check for section strength only. [10]



Total No. of Questions : 6]

SEAT No. :

P900

[Total No. of Pages : 3

APR - 15 / In. SPL - 8

T.E. (Mechanical) (In sem.) (Semester - I)

THEORY OF MACHINES - II

(2012 Pattern)

*Time : 1 Hour]*

*[Max. Marks :30*

*Instructions to the candidates :*

- 1) *Answer Q.1 or Q.2, Q.3 or Q.4 Q.5 or Q.6.*
- 2) *Neat diagrams must be drawn wherever necessary.*
- 3) *Figures to the right side indicate full marks.*
- 4) *Assume suitable data if necessary.*

**UNIT - I**

**Q1) a) Define the following terms : [4]**

- i) Pressure angle.
  - ii) Circular pitch.
  - iii) Path of contact.
  - iv) Contact ratio.
- b) Two involute gears with  $20^\circ$  pressure angle are in mesh. If the gears have 20 and 60 teeth respectively and module of 5 mm, determine the maximum length of path of approach and path of recess. Also determine the addendum on pinion and gear based on maximum path of contact. [6]

OR

**Q2) A pair of  $20^\circ$  full depth involute gears with a module of 6 mm have 18 and 72 teeth respectively. Taking addendum on pinion and gear as per 20 degree full depth involute system. [10]**

Determine :

- i) Contact ratio.
- ii) Maximum velocity of sliding if pinion rotates at 1440 rpm.
- iii) All dimensions of tooth profile such as addendum, dedendum, base circle diameter and clearance.

**P.T.O.**

## UNIT - II

**Q3) a)** Explain force analysis of Bevel gear with neat sketch. **[4]**

b) The following data relate to two spiral gears in mesh : **[6]**

- Shaft angle  $70^\circ$ ,
- Center distance 160 mm (approx.),
- Normal circular pitch 8 mm,
- Gear ratio 3,
- Friction angle  $5^\circ$ .

For maximum efficiency of drive determine,

- i) The spiral angles of the teeth.
- ii) The number of teeth.
- iii) Exact center distance.
- iv) Pitch diameters.

OR

**Q4)** A three start worm has a pitch diameter of 82 mm and a pitch of 16 mm. It rotates at 1000 rpm and 35 teeth worm gear. If coefficient of friction is 0.06. Find the following : **[10]**

- i) The helix angle of worm.
- ii) The speed of the gear.
- iii) The center distance.
- iv) The efficiency.
- v) The lead angle for maximum efficiency.

**UNIT - III**

**Q5)** Fig. 1 shows a bevel epicyclic gear train used in a lathe headstock. The number of teeth on the wheels B, C, D, E and F are 19, 57, 20, 40 and 76 respectively. If the input shaft on which gear B is mounted rotates at 300 rpm, what will be the speed of output shaft when gear B is fixed and gear F is rotated at 500 rpm opposite to the input shaft. **[10]**

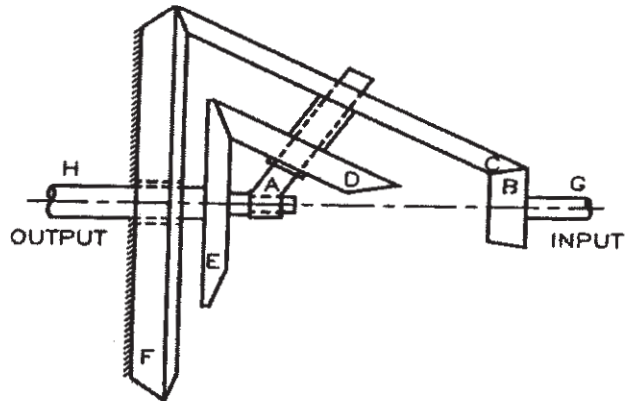

Figure 1

OR

**Q6)** Fig. 2 shows two gear  $S_1$  &  $S_2$  which are integral with driving shaft. The gear  $P_1$  revolves on a pin attached to the arm A which is integral with the driven shaft &  $P_2$  gears with the annular gear  $I_2$  which is co-axial with the driving shaft. The gear  $P_2$  meshes with the gear  $S_2$  & fixed annular gear  $I_2$  & revolves on a pin fixed to annular wheel  $I_1$ . The number of teeth are,  $T_{S_1} = 20$ ,  $T_{S_2} = 22$ ,  $T_{I_1} = 81$  &  $T_{I_2} = 86$ . If the input shaft is rotating at 1500 rpm, find out the output speed. **[10]**

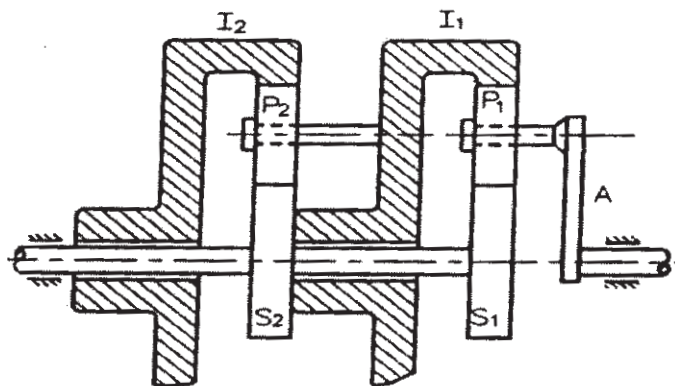

Figure 2

