



[4658] – 158

Seat No.	
-------------	--

**T. E. (Computer) (Semester – II) Examination, 2014
SYSTEMS PROGRAMMING AND OPERATING SYSTEMS
(2008 Course)**

Time : 3 Hours

Max. Marks : 100

- Instructions :** 1) Answer **any three** questions from **each** Section.
2) Answers to the **two** Sections should be written in **separate** books.
3) Neat diagrams must be drawn **wherever** necessary.
4) Black figures to the **right** indicate **full** marks.
5) Assume suitable data, **if** necessary.

SECTION – I

1. a) What are the tasks of analysis and synthesis phase of language translator ? 6
- b) What are the features of assembly language ? 4
- c) Differentiate between literal and immediate operand. 6

OR

2. a) Define Macro. What are the advantages of macro facility ? How they are different from functions ? 6
- b) Draw flow chart for single pass macro processor to handle definitions inside definitions. 10
3. a) With the help of diagram explain the general loader scheme. 6
- b) Draw the flow chart for Pass II of direct linking loader. 10

OR

4. a) What is the use of overlay structure ? Explain with an example. 8
- b) What is the need of DLL ? How dynamic linking can be done with or without import ? 8
5. a) What are system calls ? Enlist major category of system calls. 6
- b) What are different structures of operating system ? Describe. 12

OR

6. a) Describe various processor scheduling methods. 12
- b) Describe the various features of UNIX OS. 6

P.T.O.



SECTION – II

7. a) Explain the concept of monitor with neat diagram. Implement a solution to bounded buffer producer/consumer problem using Monitor. **8**
 b) What are the difficulties that may arise when a process is rolled back as a result of deadlock ? **4**
 c) Explain in brief how message passing mechanism is used for synchronization. **6**
 OR
8. a) What is critical region? Explain in detail. **6**
 b) Explain how mutual exclusion is achieved with hardware support using special machine instructions. State the advantages and disadvantages of using special machine instruction approach. **8**
 c) State the necessary conditions for deadlock occurrence in a system. **4**
9. a) Compare the following memory management techniques on their strengths and weaknesses- fixed partition, dynamic partition, simple paging, simple segmentation, Virtual memory management, Virtual memory segmentation. **10**
 b) State and explain different memory management requirements. **6**
 OR
10. a) Explain the following terms in brief
 i) Working set model ii) Thrashing iii) Lazy swapper iv) Compaction. **8**
 b) Consider the following address register with 100 bytes page.
 0100, 0432, 0101, 0612, 0102, 0103, 0104, 0451, 0256, 0611, 0102, 0103, 0104, 0610, 0103, 0234, 0104, 0321, 0613.
 Calculate page faults 1) LRU 2) FIFO 3) Optimal
 Frame size is 3. Specify which algorithm is better ? **8**
11. a) Describe any four types of file organizations. **8**
 b) Describe the 3 methods of record blocking with the help of neat diagrams. **8**
 OR
12. a) The requested tracks in the order received are
 55, 58, 39, 18, 90, 160, 150, 38, 184.
 Starting track is 100. Perform the computation for the following disk scheduling algorithm : **8**
 i) SSTF ii) FCFS iii) C-SCAN
 b) What is RAID ? Explain the advantages and disadvantages of RAID. Also explain seven RAID levels in brief. **8**



Seat No.	
----------	--

**T.E. (E&TC) (Semester – II) Examination, 2014
SIGNAL CODING AND ESTIMATION THEORY
(2008 Course)**

Time : 3 Hours

Max. Marks : 100

- Instructions :** 1) Answer to the **two** Sections should be written in **separate** answer books.
2) Answer **any three** questions from **each** Section.
3) **Neat** diagrams must be drawn **wherever** necessary.
4) Figures to the **right** indicate **full** marks.
5) Assume suitable data **if** necessary.

SECTION – I

1. a) In fax transmission of picture there are about 2.25×10^6 picture elements per frame. For good reproduction, 12 brightness levels are necessary; assuming all these levels is equiprobable.
- i) Calculate the channel bandwidth required to transmit 1 picture for every 3 minutes for SNR = 30 dB.
 - ii) If SNR requirement increases to 40 dB; calculate bandwidth.
 - iii) Explain the trade off between bandwidth and SNR. 8
- b) Consider the given binary channel. 8

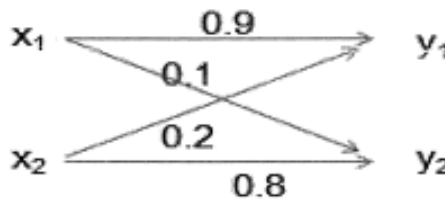

- i) Construct the channel matrix.
- ii) Find out the value of $P(y)$; if the source is equiprobable.
- iii) Calculate all entropies, mutual information and channel capacity.

OR

2. a) A source emits letters from an alphabet $A = \{a_1, a_2, a_3, a_4, a_5\}$ with probabilities $P(a_1) = 0.15$, $P(a_2) = 0.04$, $P(a_3) = 0.26$, $P(a_4) = 0.05$, $P(a_5) = 0.50$.
- i) Calculate the entropy of the source.
 - ii) Find a Huffman code for the source.
 - iii) Find the average length of the code.
 - iv) Redundancy.
 - v) Variance. 10
- b) Explain Differential Entropy and Mutual Information for continuous Ensembles. 6



- 3. a) Explain Shannon third theorem (Information Capacity Theorem or Shannon Hartley theorem) and prove that when $B \rightarrow \infty$ then Channel capacity $= S/No. \log_2 e = 1.44 S/No.$ 8
- b) Find out the encoding performed by the Lempel-Ziv algorithm on the binary Sequence 000101110010100101... 8

OR

- 4. a) Consider (7, 4) LBC with the generator matrix 10

$$G = \begin{matrix} 1 & 0 & 0 & 0 & 1 & 1 & 0 \\ 0 & 1 & 0 & 0 & 0 & 1 & 1 \\ 0 & 0 & 1 & 0 & 1 & 1 & 1 \\ 0 & 0 & 0 & 1 & 1 & 0 & 1 \end{matrix}$$

- i) Find out all possible code vectors, error detection and correction capability.
- ii) Prepare error decoding table (look up table).
- iii) If the received code vector is 1111110, find out corrected code vector.
- iv) State relation between minimum distance and HT matrix.

- b) Explain the following term 6
 - i) JPEG
 - ii) DCT

- 5. a) Diagram an convolution encoder of $O_1 = 110$ and $O_2 = 011$, draw the state table and use viterbi algorithm to decode the encoded sequence 10, 11, 11, 11, 01. 10

- b) Write a short note on Turbo codes. 8

OR

- 6. a) Compared state, tree and Trellis representation of convolution codes with example. 9

- b) Find the Asymptotic Coding Gain for the above TCM Encoder. 9

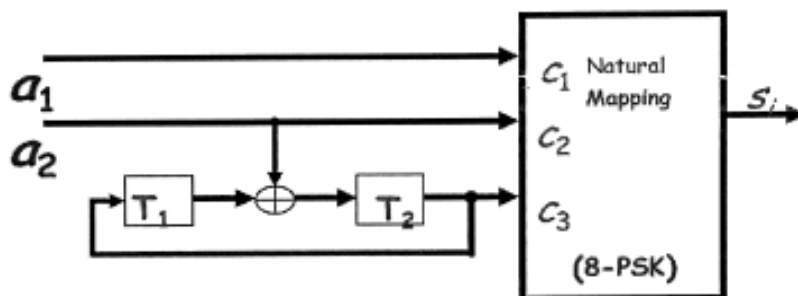



SECTION – II

7. a) Find the generator polynomial for BCH code over GF(8) using primitive polynomial $p(z) = z^3 + z + 1$ over GF(2) codeword. The code should correct $t = 1, 2, \dots$ errors. **10**

b) What is Cryptography ? Explain RSA Algorithm. **8**

OR

8. a) Consider the (31, 15) Reed-Solomon code. **9**

i) How many bits are there in a symbol of the code ?

ii) What is the block length in bits ?

iii) What is the minimum distance of the code ?

iv) How many symbols in error can the code correct ?

b) Define the terms related to BCH Codes Primitive Polynomial, Minimal Polynomial and Generator Polynomial. **9**

9. a) In the received signal under hypothesis H_1 and H_0 was **10**

$$H_1 : Y_k = m + N_k, \quad k = 1, 2, \dots, K$$

$$H_0 : Y_k = N_k, \quad k = 1, 2, \dots, K$$

i) Assuming the constant m is unknown. Obtain the Maximum Likelihood estimation of the mean.

ii) Suppose now mean ' m ' is known but the variance is unknown. Obtain the MLE.

b) Write a note on Bayes Criteria. **6**

OR

10. a) Let Y_1 and Y_2 be two statistically independent Gaussian random variables, such that $E[Y_1] = m$, $E[Y_2] = 3m$, and $\text{var}[Y_2] = 1$; m is unknown. Obtain the ML estimate of m . **8**

b) What are the criteria for the good Estimator, calculate the unbiased Estimation of DC level with ' A ' as unknown in presence of WGN ? **8**

11. a) In a digital communication system, consider a source whose output under hypothesis H_1 is a constant voltage of value m , while its output under H_0 is zero. The received signal is corrupted by N , an additive white Gaussian noise of zero mean, and variance σ^2 .

i) Set up the likelihood ratio test and determine the decision regions.

ii) Calculate the probability of false alarm and probability of detection. **8**

b) Explain the concept of MINIMAX detector in detail. **8**

OR



12. a) A ternary communication system Transmits one of three amplitude signals $\{1, 2, 3\}$ with equal probabilities, the independent received signal samples under each hypothesis are

$$H_1 : Y_k = 1 + N \quad k = 1, 2, \dots, K,$$

$$H_2 : Y_k = 2 + N \quad k = 1, 2, \dots, K,$$

$$H_3 : Y_k = 3 + N \quad k = 1, 2, \dots, K,$$

The additive noise N is Gaussian with zero mean and variance σ^2 , the costs are $C_{ii}=0$, and $C_{ij} = 1$, determine the decision regions. **10**

- b) Write short note on Neyman-Pearson detector. **6**



Seat No.	
----------	--

T.E. (Electronics) (Semester – II) Examination, 2014
DRIVES AND CONTROLS
(2008 Course)

Time : 3 Hours

Max. Marks : 100

SECTION – I

1. a) State the equations that govern the operation of separately excited DC motor, Express speed in terms of other parameters. 5
b) Draw a circuit diagram of separately excited DC motor drive with three phase full converter for armature and three phase semi converter for field control. 5
c) A 15 hp, 220 volts separately excited dc motor controls a load requiring a torque of 45 Nm at a speed of 1200 r.p.m, $R_f = 147 \Omega$. $R_a = 0.25 \Omega$ $K_v = 0.7032$. $V_f = 220$ volts. Calculate back emf E_g , armature voltage V_a and rated armature current of the motor. 8

OR

2. a) State the equations that govern the operation of DC series motor. Express Speed in terms of other parameters. 5
b) Draw a circuit diagram of separately excited DC motor drive with single phase dual converter for armature and three phase semi converter for field control. 5
c) A 30 Hp, 440 volts separately excited dc motor controls a load requiring a torque of 85 N.m at a speed of 1200 r.p.m. $R_f = 294 \Omega$, $R_a = 0.12 \Omega$, $K_v = 0.7032$. $V_f = 440$ volts. Calculate back emf E_g , armature voltage V_a and rated armature current of the motor. 8
3. a) Starting, from the basic control equations develop control block diagram for the open loop control of separately excited DC motor and calculate $\Delta w / \Delta V$ and $w / \Delta T_L$. 10
b) Draw block diagram of closed loop control of separately excited DC motor calculate the transfer function. 6

OR

4. a) Starting, from the basic control equations develop control block diagram for the open loop control of DC series motor and calculate $\Delta w / \Delta V$ and $\Delta w / \Delta T_L$. 10
b) Draw block diagram of closed loop control of s DC series motor and calculate the transfer function. 6
5. a) Derive expression for maximum torque and maximum slip for an induction Motor assuming $R_s = 0$. 4
b) Explain the V/f control drive for an induction motor. 6
c) A 460 volts/60 Hz 3 phase induction motor has $R_s = 0.08 \Omega$, $R_r = 0.1 \Omega$, $X_s = 0.62 \Omega$, $X_r = 0.92 \Omega$, $X_m = 6.7 \Omega$. Caculate synchronous speed w_s , The slip s , input current i_i , input power p_i . 6

OR

P.T.O.



- 6. a) Explain slip power, and methods to recover slip power. 6
- b) Explain stator voltage control drive for an induction motor. 4
- c) A 460 volts/60 Hz 3 phase induction motor has $R_s = 0.08 \Omega$, $R_r = 0.1 \Omega$, $X_s = 0.62 \Omega$, $X_r = 0.92 \Omega$, $X_m = 6.7 \Omega$. Calculate synchronous speed ω_s , The slip s , input current I_i , input power P_i . Use following equivalent circuit of induction motor. 6

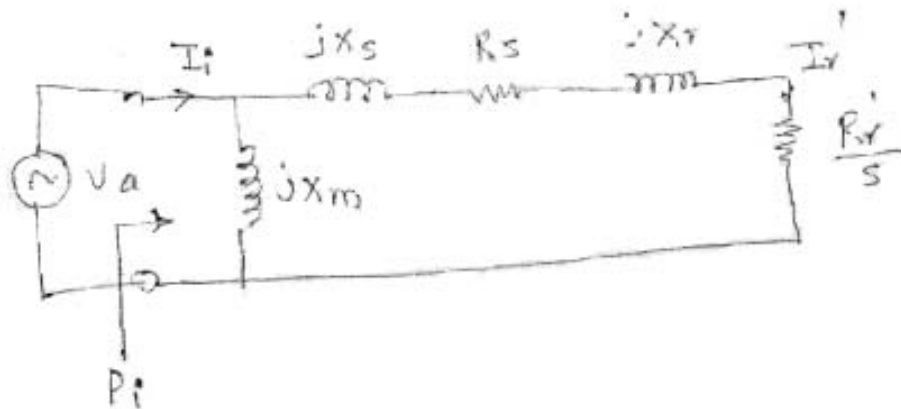

SECTION – II

- 7. a) Explain with necessary diagram, the operation of cylindrical rotor motor. 8
- b) Draw and explain the frame speed characteristics of synchronous reluctance motor at constant voltage and frequency. 10
- OR
- 8. a) Explain briefly the operation of self controlled synchronous motor fed from three phase inverter. 8
- b) Explain the salient pole synchronous motor with vector diagram. 10
- 9. Describe construction and working of variable reluctance stepper motor. List down its advantages and disadvantages. 16
- OR
- 10. a) With the help of neat circuit diagram and waveforms explain the operation of brushless dc motor. 10
- b) Write short note on switched reluctance motor. 6
- 11. a) With relevant diagram explain traction motor drive. 8
- b) Explain operation of fuzzy logic based wind generation system. 8
- OR
- 12. a) Explain 'tuning of a controller' for a drive system. 8
- b) Explain neural network based PWM controller. 8



[4658] – 117

Seat No.	
----------	--

T.E. (Chemical) (Semester – II) Examination, 2014
CHEMICAL REACTION ENGINEERING – I
(2008 Pattern)

Time : 3 Hours

Total Marks : 100

- Instructions :**
- 1) Answer **any three** questions **each** from Section I and II.
 - 2) Answers to the two Sections should be written in **separate** books.
 - 3) **Neat** diagrams must be drawn **wherever** necessary.
 - 4) Black figures to the **right** indicate **full** marks.
 - 5) **Use** of logarithmic tables slide rule, Mollier charts, electronic pocket calculator and steam tables is **allowed**.
 - 6) Assume suitable data, if **necessary**.

SECTION – I

1. a) How kinetic model is tested, explain rules for matching the predicted rate expression and found experimentally. 4
- b) On doubling the concentration of the reactant the rate of reaction triples. Find the reaction order. 4
- c) The rate constant of certain reaction are 1.6×10^{-3} and $1.625 \times 10^{-2} \text{ sec}^{-1}$ at 10°C and 30°C . Calculate the activation energy. 4
- d) Differentiate elementary and non-elementary reaction. 4

OR

2. a) Explain rate of reaction and give various ways of expressing the reaction rate. 6
- b) A certain reaction has a rate given by 6
$$-r_A = 0.005 CA^2, \text{ mol/cm}^3 \cdot \text{min}$$

If the concentration is expressed in mol/lit and time in hours, what would be the value and unit of rate constant ?
- c) Explain the kinetic model for non-elementary reaction. 4

P.T.O.



3. a) The first order reversible liquid reaction $A \rightarrow R$, $C_{A0} = 0.5$ mol/lit, $C_{R0} = 0$ takes place in a batch reactor. After 8 min, conversion of A is 33% while equilibrium is 66%. Find rate equation for this reaction. 10

b) At certain temperature, the half life period and initial concentration for a reaction are

$$t_{1/2} = 420 \text{ sec}, C_{A0} = 0.405 \text{ mol/lit}$$

$$t_{1/2} = 275 \text{ sec}, C_{A0} = 0.64 \text{ mol/lit}$$

Find the rate constant of reaction. 6

OR

4. a) Show that, $C_A = C_{A0} (1 - X_A)$. 4

b) Aqueous A at a concentration $C_{A0} = 1$ mol. lit is introduced into a batch reactor where it reacts away to form product R according to stoichiometry $A \rightarrow R$. The concentration of A in the reactor is monitored at various times as shown below :

t (min)	0	100	200	300	400
C_A (mol/m ³)	1000	500	333	250	300

For $C_{A0} = 500$ mol/m³, find the conversion of reactant after 5 hours in batch reactor. 12

5. a) A homogeneous gas reaction $A \rightarrow 3R$ has reported rate at 215°C
 $-r_A = 10^{-2} C_A^{1/2}$ [mol/lit. sec]. 12

Find the space time needed for 80% conversion of 50% A and 50% inerts feed to a Plug Flow Reactor operating at 215°C and 5 atm ($C_{A0} = 0.0625$ mol/lit).

b) Derive performance equation of Plug Flow Reactor. 6

OR

6. a) Deduce the performance equation for recycle reactor. 12

b) Derive performance equation of Mixed Flow Reactor. 6



SECTION – II

7. a) Liquid phase reactant A decomposes as per following scheme.

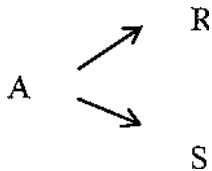

With rates $r_R = K_1 C_A^2$ $K_1 = 0.4 \text{ m}^3/\text{mol} \cdot \text{min}$.

$$r_S = K_2 C_A \quad K_2 = 2 \text{ min}^{-1}$$

Feed contains A with $C_{A0} = 40 \text{ mol/m}^3$ enters the reactor decomposes and mixture of A, R and S leaves the reactor. Find operating conditions (X_A, C_R, ξ) which maximizes C_R in mixed flow reactor.

10

b) Explain in detail

6

a) Instantaneous yield (ψ)

b) Overall yield (ϕ)

OR

8. Often a desired reaction is accompanied by a variety of undesired side reactions, some of higher order some of lower order. To see which type of operation gives the best product distribution. Consider the parallel decomposition of A, $C_{A0} = 2$.

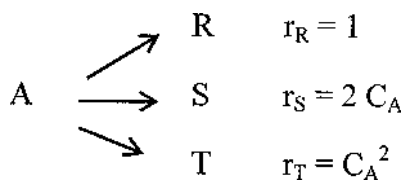

Find the maximum expected C_S for isothermal operations

a) In a mixed reactor

b) In a plug flow reactor.

16

9. Determine the equilibrium conversion for the following elementary reaction between 0°C to 100°C at 298 K

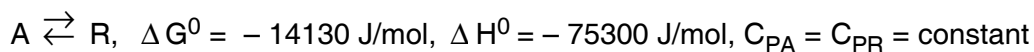

i) Construct a plot of temperature vs conversion

ii) What restrictions should be placed on reactor operating isothermally if conversion of 85% or higher is desired ?

16

OR

[4658] – 117

-4-



10. Calculate the heat of reaction at 600°C of the reaction.

16

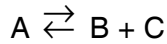

Heat capacities of the reacting species may be expressed as

$$C_p = \alpha + \beta T + \gamma T^2 + \delta T^3$$

Component	α	$\beta \times 10^2$	$\gamma \times 10^5$	$\delta \times 10^9$
A	- 0.24	8.65	- 5.12	12.05
B	- 1.30	8.40	- 5.55	14.25
C	6.45	0.104	- 0.008	0

The heat of reaction at the standard state (25°C) of the reaction is 27.23 k cal/g mol.

11. Write notes on (**any three**) :

18

- Tank in series model
- C and E curve
- Micro and macro mixing of fluids
- Segregation model
- Dispersion flow model.

OR

12. A sample of tracer was injected into a vessel and effluent concentration was measured as function of time. Construct C and E and determine the fraction of material leaving the vessel that has spent 33 and 6 min and fraction of material that has spent 7.75 and 8.2 min in the vessel.

18

t (min)	0	1	2	3	4	5	6	7	8	9	10	12	14	16
C (g/m ³)	0	1	5	8	10	8	6	4	3	2.2	1.5	0.6	0	0



[4658] – 106

Seat No.	
-------------	--

T.E. (Printing) (Semester – II) Examination, 2014
OFFSET MACHINES – II
(2008 Course)

Time : 3 Hours

Max. Marks : 100

Instructions : 1) **All** questions are **compulsory**.
2) Answers to **two** Sections should be written in **separate** books.

SECTION – 1

1. Explain the following related to roll to web processing. **16**
- 1) Different parts of reel
 - 2) Reel stands
 - 3) Festoon
 - 4) Dancer roller.

OR

1. Explain the following :
- 1) What conditions are considered at the time of selection of a specific splice pattern. **8**
 - 2) Explain the significance of the following : **8**
 - 1) Festoon
 - 2) Paster brush
 - 3) Pressure arm
 - 4) Knife.
2. 1) Describe procedure to check roller settings by stripe method. **8**
- 2) Describe problem of glazed rollers. Explain use of durometer. **8**

OR

2. Explain : **16**
- 1) Y type configuration
 - 2) Vertical press
 - 3) Blanket cylinder construction in web offset
 - 4) Satellite press.
3. Explain setting of coldset inks. Describe any high velocity hot air type of dryer. **18**
- OR
3. 1) Explain double former folding mechanism and its use in commercial printing. **10**
- 2) Write significance of Tucker blades and jaws. **8**

P.T.O.



SECTION – 2

4. State effects on web tension due to ink water conditions on press and due to moisture in web. **18**

OR

4. Explain various tension zones in the web press. **18**

5. Explain use of chillers in web offset. How temperature control is done for the web on heatset press ? **16**

OR

5. Explain why : **16**

- 1) Use of Web Preconditioner.
- 2) Web break sensors are placed on the same side.
- 3) Remoisturizer unit.
- 4) Pyrometers are used.

6. Explain following troubles : **16**

- 1) Curved edges
- 2) Blistering
- 3) Tone value increase
- 4) Poor drying of ink.

OR

6. Explain problems occurring due to following defects : **16**

- 1) Damaged end
- 2) Soft end and baggy end
- 3) Telescoped roll
- 4) Water damage.



[4658] – 108

Seat No.	
-------------	--

**T.E. (Printing) (Semester – II) Examination, 2014
DIGITAL WORKFLOW AND IMAGE SETTING
(2008 Course)**

Time : 3 Hours

Total Marks : 100

Instruction : All questions are compulsory.

SECTION – I

1. Which are different types of file formats used in file transfer from client to service provider ? Explain each in details with suitable example. **16**
OR
What is file compatibility ? Why it is significant in print workflow ? Explain in detail. **16**
2. Explain principle and working of Internal drum image setter with neat and labelled diagram. **16**
OR
Explain principle and working of external drum image setter with neat and labelled diagram. **16**
3. What is PDF ? What are its variants ? Explain in detail. **18**
OR
Draw a workflow diagram for conventional and automatic pre-press workflow and explain. **18**

SECTION – II

4. What is file compression ? Explain any type in detail. **16**
OR
Explain following terms : **16**
 - 1) Vector image
 - 2) Raster image
 - 3) Spot size
 - 4) Resolution.
5. What are different beam deviation technologies used in capstan image setter ? Explain in detail. **18**
OR
What are output file formats ? Explain PS and its working in detail. **18**
6. Draw the workflow for commercial printing job, any case and explain in detail. **16**
OR
What is workflow for newspaper production ? Explain in detail. **16**



Seat No.	
-------------	--

T.E. Chemical (Semester – II) Examination, 2014
TRANSPORT PHENOMENA
(2008 Course)

Time : 3 Hours

Max. Marks : 100

- Instructions :** 1) Answers to the **two** Sections should be written in **separate** books.
2) **Neat** diagrams must be drawn **wherever** necessary.
3) **Black figures** to the **right** indicate **full** marks.
4) Your answers will be **valued** as a whole.
5) **Use** of logarithmic tables, slide rule, Mollier charts, electronic pocket calculator and steam tables is **allowed**.
6) **Assume** suitable data, if necessary.

SECTION – I

1. a) Explain time independent fluids and time dependent fluids. 6
b) Compute the mean molecular velocity \bar{u} , and mean free path λ of O_2 at 1 atm and 273°K. Assume $d = 3\text{Å}$, what is the ratio of the mean free path to the molecular diameter in this situation ? 6
c) An horizontal annulus is 27 ft. long. The outside radius of inner cylinder is 0.495 inch. The inside radius of outside cylinder is 1.1 inch. The fluid density is 80.3 lb / ft³ and viscosity is 136.8 lb.m/fts. What is the volume rate of flow, the impressed pressure drop is 5.39 Psi ? 6
- OR
2. a) Derive the expression of velocity and average velocity for flow of falling film with variable viscosity i.e. $\mu = \mu_0 e^{-\alpha x / \delta}$. 12
b) An oil has Kinematic viscosity of $2 \times 10^{-4} \text{ m}^2/\text{s}$ and density 800 kg/m². What should be mass flow rate of this film down a vertical wall in order to have film thickness of 2.5 mm. 6
3. a) A small capillary tube with an inside diameter of $2.2 \times 10^{-3} \text{ m}$ and length of 0.317 m is being continuously used to measure the flow rate of liquid having density of 990 kg / m³ and $\mu = 1.13 \times 10^{-3} \text{ Pa. Sec}$. The velocity of liquid is 0.275 m/s.. Calculate pressure drop. 6
b) Derive Hagen – Poiseuille equation for flow through circular tube. 10

OR



4. a) Explain macroscopic mass balance equation. **4**
 b) Derive Ergun equation for flow of a fluid through packed column. **12**
5. a) Explain thermal energy balance equation. **4**
 b) Derive the expression of heat flux and temperature distribution for nuclear heat source of spherical form surrounded by spherical shell of aluminium cladding. **12**

OR

6. An oil is acting as a lubricant for a pair of cylindrical surfaces. The angular velocity of the outer cylinder is 7908 rpm. The outer cylinder has a radius of 5.08 cm and the clearance between the cylinder is 0.027 cm. What is the maximum temperature in the oil if both wall temperature are known to be 70°C ? Assume cylindrical surface as of concentric type.

The physical properties of oil are

Viscosity 92.0 Cp

Density 1.22 g cm⁻³

Thermal conductivity 0.0055 Cal Sec⁻¹ °C⁻¹. **16**

SECTION – II

7. a) What are the characteristic dimensionless group that arise in the correlations for Nusslet number for forced convection and free convection ? Give their significance. **6**
 b) What are semieprirical expressions for turbulent energy flux and what are their applications ? **10**

OR

8. a) Derive expression for temperature rise, maximum temperature rise, average temperature rise and heat flow at the surface for heat conduction with electrical heat source. **8**
 b) State and explain comparison of forced and free convection in nonisothermal systems. **8**
9. a) Discuss the theory of ordinary diffusion in gases at low density. **8**
 b) Estimate diffusivity for acetic acid in dilute aqueous solution at 12.5°C. The density of acetic acid at its normal boiling point is 0.937 g/cm³

$$\psi_B = 2.6$$

$$M_B = 18.02$$

$$\mu = 1.22 \text{ Cp.}$$

8

OR



10. Show that rise $N_{A_2} | Z = Z_1 = \frac{CD_{AB}}{(Z_2 - Z_1)X_{Bin}} (X_{A_1} - X_{A_2})$

If the rate of mass transfer is related to a characteristic concentration driving force $X_{A_1} - X_{A_2}$ for diffusion through a stagnant gas film. **16**

11. a) Discuss analogies among mass, heat and momentum transfer with suitable example. **9**
b) Explain diffusion in laminar falling film. **9**

OR

12. Write note on :
a) Co-relation of Binary Mass Transfer coefficient in one phase at low mass transfer rates. **6**
b) Chilton and Colburn J. factor analogy. **6**
c) Penetration theory for transfer coefficients at high mass transfer rates. **6**



Seat No.	
-------------	--

**T.E. (Petroleum) (Semester – II) Examination, 2014
PETROLEUM PRODUCTION ENGINEERING – I
(2008 Course)**

Time : 3 Hours

Max. Marks : 100

- Instructions :** 1) Answer Q. No. 1 or Q. No. 2, Q. No. 3 or Q. No. 4, Q. No. 5 or Q. No. 6, from Section – I and Q. No. 7 or Q. No. 8, Q. No. 9 or Q. No. 10, Q. No. 11 or Q. No. 12 from Section – II.
- 2) Answers to the **two** Sections should be written in **separate** answer books.
- 3) **Neat** diagrams must be drawn **wherever** necessary.
- 4) Figures to the **right** side indicate **full** marks.
- 5) **Use** of Calculator is **allowed**.
- 6) Assume **suitable** data **if necessary**.

SECTION – I

1. Explain the working of PCP and Jet pump in brief. 18
- OR
2. Discuss usability of ESP, plunger lift and SRP only in terms of excellent/good/fair/poor in a tabular form for following well conditions. Low PI, Low GOR, adaptability to deviated wells, capability to produce sand, high volume lift capability and ability to handle viscous fluids. 18
3. a) Calculate the casing pressure at 8000 ft, required to open the valve if, $A_b = 0.77 \text{ inch}^2$, $R = 0.085$, $P_d = 730 \text{ psi}$, $P_t = 300 \text{ psi}$. What is the tubing effect caused by tubing pressure? How much pressure it would require to open the valve in the casing if, tubing pressure is zero psi at valve depth. Also explain meaning of spread and find its value for this valve. 8
- b) Draw the schematic sketch and explain in brief operation of intermittent flow unloading process in gas lift system. 8
- OR
4. a) Which method or methods of artificial lifting you will propose for the following requirements and why? Write in brief. 8
- i) low GOR wells with viscous oil
- ii) oil production from unconsolidated formation along with high GOR.
- b) Describe the method to determine depth of point of gas injection for a continuous flow injection and explain steps to calculate daily requirement of total injection gas. 8

P.T.O.



- 5. a) Discuss method to select a suitable electrical submersible pump and necessary details of it. 10
- b) Discuss in brief any one method or procedure for valve spacing used in high bhp, high PI wells. 6

OR

- 6. a) Discuss the effect of following on functioning of ESP, 8
 - i) Viscous oil
 - ii) Medium GOR
- b) Draw schematic sketch of a surface and subsurface ESP Set-up. 8

SECTION – II

- 7. Write in brief the functions of various components required in SRP system. 18

OR

- 8. Calculate : PPRL, MPRL, counter balance required and peak torque for SRP with following well conditions. Pumping depth = 6800 ft, desired fluid production = 190 bpd, Stroke length = 64 in, Volumetric efficiency = 72%, Pumping speed = 17 spm, Pump diameter = 1¼ inch. Rod number = API No. 76 (1.791 lb/ft), Fluid specific gravity = 0.94. Indicate all the components. 18
- 9. Draw neat schematic sketch of a typical petroleum production system and discuss procedure of doing nodal analysis for any two nodes in brief. 16

OR

- 10. Given data : (Relevant) 16

Surface temperature, $T_s = 110$ °F, Gas gravity, $\gamma_g = 0.86$, $C = 0.0006$ inch (Pipe roughness), TVD of wellbore, $H = 11,100$ ft, Reservoir temperature, $T_R = 260$ °F, Gas viscosity, $\mu_g = 0.012$ Cp, Drainage radius, $r_e = 1100$ ft, wellbore radius, $r_w = 0.50$ ft., Skin factor, $S = +2$, Formation thickness, $h = 25$ ft., Perforation diameter = 0.7 inch., $z = 0.97$, Gravel permeability = 40 darcys, Screen O.D. = 3.06 inch., Hole diameter = 12.25 inch, 4 and 12 perforations per foot are to be checked.

Use given bottom hole flowing pressure at sandface Vs production of gas flow rate and pressure drop in 2.441 inch tubing against the said flow rate and well conditions. Workout the operating points to decide the perforation sizing, flow capacity and pressure loss across the sandface.

Q_{sc} Mscfd	Pwfs. Psia	ΔP psi (d = 2.441 inch)
25,000	5200	500
20,000	5340	1500
15,000	5430	2100
10,000	5580	3000
5,000	5730	3600



11. Discuss specific criteria's to consider a wellbore for acidizing job. Also draw and explain typical DST curve Indicate all the features of it. **16**

OR

12. Write short note on : **16**

- a) Formation damage
- b) Fracturing procedure
- c) Reactions in sandstone acidizing job
- d) Fracturing models.



[4658] – 147

Seat No.	
-------------	--

T.E. (Polymer) (Semester – II) Examination, 2014
POLYMER CHEMISTRY – II
(2008 Course)

Time : 3 Hours

Max. Marks : 100

- Instructions :** 1) Answer to the **two** Sections should be written in **separate** answer books.
2) Answer **any three** questions from **each** Section.
3) **Neat** diagrams must be drawn **wherever** necessary.
4) Figures to the **right** side indicate **full** marks.
5) **Use** of Calculator is **allowed**.
6) Assume **suitable** data **if necessary**.

SECTION – I

1. a) Differentiate between Novolaks and Resols w.r.t method of synthesis, structure and curing mechanism. 9
b) What are amino resins ? Explain the synthesis of any one with appropriate chemical reactions. 9
- OR
2. a) Discuss the compounding ingredients and role of each one of them w.r.t phenol formaldehyde resin. 9
b) Write a note on Silicone resins. 9
3. a) Discuss vinyl ester resins w.r.t synthesis and properties. 8
b) With suitable reactions discuss the various ways by which Unsaturated polyesters can be prepared. 8
- OR
4. a) Write a note on alkyd resins. 8
b) Give the properties and uses of saturated polyester resins. 8
5. a) How are epoxy resins characterized ? Discuss. 8
b) Differentiate between rigid and flexible Polyurethane foams. 8
- OR
6. a) Write a note on preparation of DGEBA type of epoxy resin. What is the significance of epoxy value and epoxy equivalent ? 8
b) Discuss the raw material used in the preparation of PU resins. 8

P.T.O.



SECTION – II

7. a) Compare properties of polyamides and polyacetals. 9
b) Why Nylons are hygroscopic ? Between Nylon 66 and Nylon 6, 10 which will be more hygroscopic ? Explain. 9
OR
8. a) Write a note on compounding and processing of Nylons. 9
b) Write a note on PEEK. 9
9. a) Write a note on modified polyimides. 8
b) Discuss the synthesis, properties and applications of PPS. 8
OR
10. a) What are polysulphones ? Comment on its properties. 8
b) Write a note on synthesis, properties and applications of PPO. 8
11. a) Compare smectic, nematic and cholestric phases with suitable diagrams w.r.t Liquid crystalline polymers. 8
b) Write a note on conducting polymers. Give examples. 8
OR
12. a) Write a note on plasma polymerization. 8
b) Discuss polymers used in membrane applications. 8



[4658] – 16

Seat No.	
-------------	--

T.E. (Mechanical) (Semester – II) Examination, 2014
MACHINE DESIGN – II
(2008 Course)

Time : 4 Hours

Max. Marks : 100

- Instructions :** 1) Solve Q. 1 or Q. 2, Q. 3 or Q. 4, Q. 5 or Q. 6 from Section – I and Q. 7 or Q. 8, Q. 9 or Q. 10, Q. 11 or Q. 12 from Section – II.
2) Answers to the **two** Sections should be written in **separate** books.
3) **Neat** diagrams must be drawn **wherever** necessary.
4) Figures to the **right** indicate **full** marks.
5) **Use** of electronic pocket calculator is **allowed**.
6) Assume **suitable** data, **if necessary**.

SECTION – I

1. a) Compare ball bearings with roller bearings. State the applications of rolling contact bearings. 4
- b) A shaft with centrally mounted helical pinion is supported by deep groove ball bearings at both ends. The centre distance between the bearings is 200 mm. the shaft transmits 5 kW power at 3000 r.p.m. The pitch circle diameter of the pinion is 80 mm. The normal pressure angle and helix angle are 20° and 25° respectively. The expected life of the bearings is 10000 hours with a reliability of 95%. Calculate the dynamic load carrying capacity of the bearing which takes up the axial thrust so that it can be selected from the manufacturer's catalogue based on the reliability of 90%. 12

OR

2. a) An equivalent radial load on a bearing varies continuously from 0 to 20 kN in a sinusoidal manner. Determine the dynamic load rating at 90% reliability, if the bearing is to have a life of 20 million revolutions at a reliability of 99%. Assume shaft speed as 1000 r.p.m.

Use life reliability relationship

$$\frac{L}{L_{10}} = \left[9.491 \log_e \left(\frac{1}{R} \right) \right]^{1.17} \quad 12$$

- b) Explain the designation of rolling contact bearing. 4

P.T.O.



3. a) Compare short and Infinitely long bearings. 4

b) The following data is given for a 360° hydrodynamic bearing : 14

Journal bearing = 50 mm

Bearing length = 50 mm

Radial load = 3.2 kN

Journal Speed = 1490 r.p.m.

Radial clearance = 0.05 mm

Viscosity of lubricant = 25 cP

Assuming that the total heat generated in the bearing is carried by the total oil flow in the bearing and Table No. 1 given in Q.4 (b) Calculate :

- I) Minimum film thickness
- II) Coefficient of friction and
- III) Power lost in friction
- IV) Flow requirement in liters/min and
- V) Temperature rise.

OR

4. a) What are the desirable properties of the sliding contact bearing material ? 4

b) The following data is given for a 360° hydrodynamic bearing : 14

Journal diameter = $50_{-0.119}^{-0.080}$

Bearing diameter = $50_{+0.000}^{+0.039}$

Bearing length = 50 mm

Journal speed = 1500 r.p.m.

Radial load 5 kN



The bearing is machined on a lathe from bronze casting, while the steel journal is hardened and ground. The surface roughness (CLA) values for turning and grinding are 3.2 and 0.8 microns respectively. For thick film hydrodynamic lubrication, the minimum film thickness should be 6 times the sum of surface roughness values for the journal and bearing. Determine the quality and quantity of the lubricant required.

Table 1 : Dimensionless performance parameters for 360° journal bearing for $l/d = 1$

$\frac{h_0}{c}$	s	$\left(\frac{r}{c}\right)_f$	$\frac{Q}{rcn_s l}$	$\frac{Q_s}{Q}$
0.9	1.33	26.4	3.37	0.150
0.8	0.631	12.8	3.59	0.280
0.6	0.264	5.79	3.99	0.497
0.4	0.121	3.22	4.33	0.680
0.2	0.0446	1.70	4.62	0.842
0.1	0.0188	1.05	4.74	0.919

5. a) Explain the significance of fatigue stress concentration factor and notch sensitivity. 4
- b) A cantilever beam of circular cross section is fixed at one end and subjected to completely reversed force of 10 kN at free end. The force is perpendicular to the axis of the beam. The distance between free and fixed ends is 100 mm. the beam is made of steel with ultimate tensile strength of 540 N/mm² and yield strength of 320 N/mm². The construction of cantilever beam is such that there is no stress concentration. The size factor, surface finish factor and reliability factor are 0.85, 0.8 and 0.868. The operating temperature is 50° c for which the temperature factor is 1.010. If the diameter of the beam is 35 mm, determine the life of the beam. 12

OR

6. a) Why modified Goodman diagram is widely accepted ? 2
- b) The work cycle of a mechanical component subjected to completely reversed bending stresses consists of the following three elements : 14
- i) ±350 N/mm² for 85% of the time,
 - ii) ±400 N/mm² for 12% of the time, and
 - iii) ±500 N/mm² for 3% of the time.

The material for the component is 50C4 ($S_{ut} = 660$ N/mm²) and the corrected endurance limit of the component is 280 N/mm². Determine the life of the components. Also determine the life of the components if the material is changed from 50C4 to 20C8 ($S_{ut} = 540$ N/mm²).



SECTION – II

7. a) Discuss the properties of friction lining material. **4**
- b) An oil immersed multi plate clutch, consisting of alternate steel and asbestos lining plates, is used to transmit 20 kW power at 3080 r.p.m. The coefficient of friction between the steel and asbestos lining plates is 0.12 and the permissible intensity of pressure is 0.3 N/mm². The radial space restriction limits the outer diameter of the asbestos lining plates to 130 mm. Assuming the suitable operating condition, determine the inner diameter of contacting surfaces, the number of steel and asbestos lining plates and the axial force required to engage the clutch. **12**

OR

8. a) What is the significance of the 'pv' value in the design of brakes ? **4**
- b) A pivoted double block brake has two shoes each of which subtend an angle of 120° at the centre of the brake drum. The diameter of the brake drum is 450 mm. and the width of the friction lining is 75 mm. The coefficient of friction is 0.2 and the maximum intensity of pressure between the lining and the brake drum is 0.5 N/mm². The pivot of each shoe is located in such a manner that the moment of force of friction on shoe about the pivot is zero. Assuming that the same actuating force is applied on both shoes, calculate, the distance of the pivot from the axis of the brake drum, the braking torque capacity of the brake and the pivot reactions. **12**
9. a) The following data given for steel gear pair transmitting 5 kW power from an electric motor running at 720 r.p.m. to a machine **14**
- Number of teeth on pinion = 21
- Number of teeth on gear = 40
- Face width = 10 m



Ultimate and Yield tensile strength for pinion and gear material = 600 N/mm² and 400 N/mm² respectively.

Tooth system = 20° full depth involute

Taking a service factor of 1.25, load concentration factor 1.6 and a factor of safety of 2, calculate :

- i) Module based on velocity factor $C_v = \frac{6}{6+v}$. Take form factor for pinion as 0.326 and for gear 0.389.
- ii) Select the standard module and calculate the main dimensions of the gear.
- iii) Specify the surface hardness of gear.

Use following data

- Load stress factor = $0.16 \left(\frac{\text{BHN}}{100} \right)^2$ N/mm²
- Standard module in mm : 1, 1.25, 2.0, 2.5, 3.0, 4.0, 5.0, 6.0, 8.0, 10.0

Assume pitch line velocity 5 m/s

b) State advantages of 20° pressure angle tooth system.

4

OR

10. The following data is given for the pair of helical gears

18

Power transmitted 20 kW

Pinion Speed 1440 rpm

Number of teeth on pinion 35

Number of teeth on gear 70

Normal pressure angle 20°

Helix angle 23°

Face width 40 mm

Velocity factor $C_v = \frac{5.6}{5.6 + \sqrt{v}}$

Ultimate tensile strength for gears 600 MPa

Service factor 1.5

Factor of safety 1.5



Deformation factor $C = 11400 X_e$

For Grade 6, $e = 8.00 + 6.3\phi$, $\phi = m + 0.25\sqrt{d}$

Estimate :

- i) The normal module and main dimensions of the gears.
- ii) Beam strength.
- iii) Dynamic load using Buckingham’s Equation.
- iv) Surface hardness for the gears and check the wear strength of the gears

Use Buckingham’s equation as
$$P_d = \frac{21v[bC \cos^2 \alpha + P_{tmax}]}{21v + \sqrt{bC \cos^2 \alpha + \alpha P_{tmax}}}$$

11. A pair of straight bevel gear mounted on shafts that are intersecting at right angles consists of a 24 teeth pinion meshing with 32 teeth gear. The pinion shaft is connected to an electrical motor developing 12.5 kW rated power at 1440 r.p.m. The starting torque of the motor is 150% of the rated torque. The pressure angle is 20°. Both the gears are made of the steel $S_{ut} = 750$ MPa. The teeth on gears are generated and finished by grinding and lapping processes to meet the requirements of class 3 grade. The factor of safety in preliminary design stages is 2.

16

- i) In the initial stages of gear design, assume that the velocity factor accounts for the dynamic load and that the pitch line velocity is 7.5 m/s. Estimate the module and determine the main dimensions of the gears.
- ii) Determine the dynamic load using Buckingham’s equation and find out the effective load for the above dimensions. Find the available factor of safety in bending.
- iii) Specify the surface hardness for the gears assuming a factor of safety of 2.

Use following data :

Lewis form factor = $0.485 - \frac{2.87}{Z}$

Load stress factor = $0.16 \left(\frac{BHN}{100} \right)^2$ N/mm²

Buckingham’s equation for dynamic load in tangential direction
$$P_d = \frac{21v(bC + P_t)}{21v + \sqrt{bC + P_t}}$$

Velocity factor $C_v = \frac{5.6}{5.6 + \sqrt{v}}$

Deformation factor $C = 11400 X_e$

Maximum expected error between meshing teeth (mm)

Module (mm)	Up to 4	5	6	7	8
Class 3 grade-error	0.0125	0.0125	0.0150	0.0170	0.0190

OR



12. a) Obtain an expression for the efficiency of a worm gear drive. 6
- b) Sketch and describe the arrangement of a work gear box in which the difference of temperature of the lubricant oil more than 100°C . 4
- c) A worm and worm wheel designated by 2/60/10/6 transmits 5 kW power at 1440 r.p.m. The worm is left handed type and rotates in an anticlockwise direction as viewed from the right side. The coefficient of friction between the worm and worm wheel is 0.05, while the normal pressure angle is 20° . 6
- Determine :
- i) The efficiency of worm gear pair and
- ii) The power lost in friction.



[4658] – 205

Seat No.	
-------------	--

**T.E. (Electronics & Telecommunication/Electronics) Examination, 2014
MECHATRONICS
(2003 Course)**

Time : 3 Hours

Max. Marks : 100

- Instructions :** 1) Answer **any 3** questions from **each** Section.
2) Answers to the **two** Sections should be written in **separate** answer books.
3) **Neat** diagram must be drawn **wherever** necessary.
4) Figures to the **right** indicate **full** marks.
5) Assume **suitable** data, if **necessary**.
6) **Use** of logarithmic calculator and steam tables electronic pocket calculator is **allowed**.

SECTION – I

1. a) Explain the term static characteristics and dynamic characteristics
i) Accuracy
ii) Precision
iii) Resolution 10
b) Explain different types of error involved in the measurement system. How to reduce these error ? 8
- OR
2. a) Define the term Mechatronics. Explain the role of mechatronics in design of robotics. 10
b) With suitable examples, explain scope and importance of mechatronics with respect to interdisciplinary approach. 8
3. a) Explain Ultrasonic transducers application as flow. 8
b) List any four sensors used for pressure measurement. Compare their different characteristics. 8
- OR
4. a) Explain proximity sensors : Inductive and capacitive. 8
b) With design aspect example, explain load cell. 8
5. a) Draw and explain in depth PLC architecture with different functions. Draw the ladder diagram to implement AND gate. 8
b) Explain role of Wien Bridge in signal conditioning circuit. 8
- OR
6. a) Write specifications of ADC and DAC related to mechatronics applications. 8
b) Draw and explain Interfacing of inputs and outputs with 89C microcontroller. 8

P.T.O.



SECTION – II

7. a) Draw block diagram of typical interface of IEEE 488 standard bus. **8**
b) Explain with neat diagram, multichannel DAS. Give typical application of DAS. **8**
OR
8. a) Explain data logger and its functions with neat block diagram. Also explain the function of each block. **8**
b) Draw and explain strip-chart recorder in mechatronics. Explain its working. **8**
9. a) Write selection criteria of control valves and motors. **8**
b) Write selection criteria of stepper motors. Also write specifications. **8**
OR
10. a) Explain construction and working of double acting cylinder. **8**
b) Compare : **8**
i) Power cable and signal cable.
ii) Electro Pneumatic and Electro-Hydraulic valves.
11. a) Write a case study on Rotary optical encoder as mechatronics design approach. **9**
b) Define SKIP control of CD player as a mechatronics design approach. **9**
OR
12. a) Define the term strain guage. Explain in detail how strain gauge is used in weighing machine. **9**
b) Design a Robotics. Walking machine that will execute different motions. **9**



Seat No.	
----------	--

**T.E. (Semester – II) (Mechanical Engineering S/W) Examination, 2014
MECHATRONICS
(2008 Course)**

Time : 3 Hours

Max. Marks : 100

- Instructions :**
- 1) Answers to the **two** Sections should be written in **separate** answer books.
 - 2) Answer Q. No. **1** or Q. No. **2**, Q. No. **3** or Q. No. **4** and Q. No. **5** or Q. No. **6** from Section – I and Q. No. **7** or Q. No. **8**, Q. No. **9** or Q. No. **10**, Q. No. **11** or Q. No. **12** from Section – II.
 - 3) **Neat** diagrams must be drawn **wherever** necessary.
 - 4) Figures to the **right** indicate **full** marks.
 - 5) **Use** of Electronic pocket Calculator is **allowed**.
 - 6) Assume suitable data, if **necessary** and mention it clearly.

SECTION – I

1. a) With respect to principle, measuring range, sensitivity; explain Thermocouple. 6
b) The divider of Figure Q. 1(b) has $R_1 = 100.0\Omega$ and $V_g = 20.00\text{ V}$. Suppose R_2 is a sensor whose resistance varies from 40.00Ω to 80.0Ω as some dynamic variable varies over a range. Then find
a) the minimum and maximum of V_D ,
b) the range of output impedance. 6

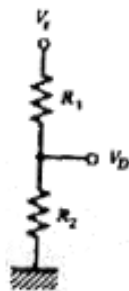

Figure Q.1 (b)

- c) With respect to principle, schematic arrangement and applications explain strain gauge type pressure sensor. 6

OR



- 2. a) Write a short note on angular velocity sensors. 9
- b) With respect to principle, construction, advantages, limitations and applications explain Potentiometer. 9
- 3. a) A Potentiometer is used as position sensor. The voltage applied is 20 V DC. If the maximum angle turned is 300° for potentiometer, calculate the transfer function of the potentiometer and voltage output corresponding to 120° . 8
- b) With respect to construction, advantages and applications explain Load Cell for force measurement. 8

OR

- 4. a) Write a short note on Capacitive type Displacement Measurement Sensor. 4
- b) Compare absolute and incremental encoders. 6
- c) Compare Thermister and RTD with respect to principle, applications and limitations. 6
- 5. a) Derive the transfer function for Mass-Spring-Damper arranged in series. 10
- b) What is the output voltage of a 8-bit DAC with a 10.0-V reference if the input is 6
 - i) $0010110101_2 = 0B5_H$?
 - ii) $20F_H$?
 - iii) What input is needed to get a 8-V output ?

OR

- 6. a) Derive the transfer function of R-L-C arranged in parallel. 8
- b) Write a short note on Analog to digital converters. 8

SECTION – II

- 7. a) A controller outputs a 4-20 mA signal to control motor speed from 140 to 600 rpm with linear dependence. Calculate current corresponding to 200 and 400 rpm and express this respective value as percentage of controller output. 8
- b) Figure Q. 7 (b) shows a block diagram. Simplify and find the relation between Y/X. 8

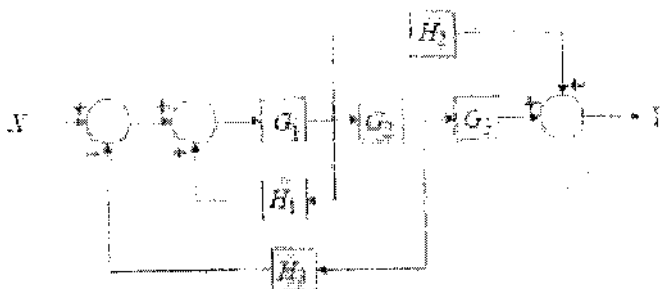

Figure Q.7 (b)

OR



8. a) Simplify the block diagram given in Figure Q. 8 (a) and obtain the expression for Y/X. 8

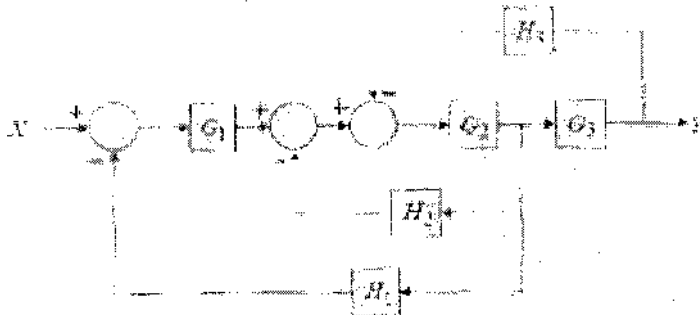

Figure Q.8 (a)

- b) Differentiate between direct action and reverse action w.r.t. controllers. 8
9. a) Given the error of Figure Q. 9 (a), plot a graph of a P controller output as a function of time. $K_p = 10$ and $P_o(0) = 15\%$. 10

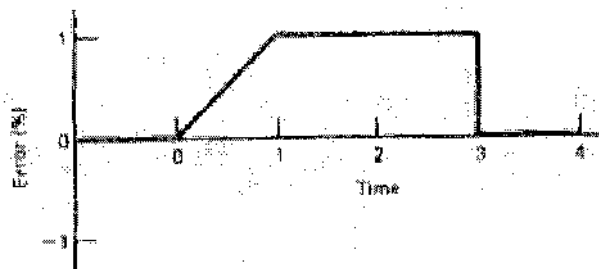

Figure Q.9 (a)

- b) Explain the significance of adding derivative action to proportional controller. Write the mathematical equation for PD controller with description of all the terms involved. 6

OR

10. a) Explain the significance of adding integral action to proportional controller. Write the mathematical equation of PI controller with description of all the terms involved. 6
- b) A proportional controller is used for speed control with a set point of 12 rpm within a range of 10 to 15 rpm. The controller output at zero error is 20%. The proportional constant $K_p = 10\%$. If the speed jumps to 13.5 rpm, calculate the error in % and controller output for next 2 seconds assuming the speed remains at 13.5 rpm. 8
- c) Define Bias Error. 2



11. a) Given two push buttons (S1 and S2) of Normally Open (NO) type, two lamps namely RED (L1) and GREEN (L2). Write the PLC ladder diagram for following objectives. **12**
- i) When S1 is pushed and S2 is not pushed RED lamp is On and latched.
 - ii) When S1 RED lamp is latched On, and S2 is pushed RED lamp is delatched and GREEN lamp is On and latched.
 - iii) When both the buttons are pushed or not pushed, both the lamps are Off and delatched, (Hint : Take third PLC output for delatching both lamps)
- b) Write a short note on use of Timers in PLC. **6**
- OR
12. a) Discuss examine On and examine Off conditions used in ladder program with an example of latching the output. **6**
- b) Write a PLC program to satisfy following objectives. **12**
- i) Start a counter C1 (count up) when S1 (push-to-on switch) is pushed. C1 is set for 10 counts.
 - ii) When counter C1 saturates, the RED lamp goes On .
 - iii) When RED lamp is On and S2 (push-to-On switch) is pushed, the C1 resets and RED lamp is Off.



[4658] – 47

Seat No.	
-------------	--

**T.E. (Production & Industrial Engg.) (Semester – II) Examination, 2014
INDUSTRIAL ENGINEERING AND QUALITY ASSURANCE
(2008 Course)**

Time : 3 Hours

Max. Marks : 100

- Instructions :**
- 1) Answers to the **two** Sections should be written in **separate** books.
 - 2) **Neat** diagrams must be drawn **wherever** necessary.
 - 3) Use of logarithmic tables, slide rule, Mollier charts, electronic pocket calculator and steam table is **allowed**.
 - 4) Assume suitable data.
 - 5) Answer **3** question from Section – I and **3** question from Section – II.
 - 6) You are advised to attempt **not** more than **3** questions in each Section.

SECTION – I

1. a) Discuss the contribution of F.W. Taylor and Gilbreth to Industrial Engineering. **8**
b) What is Industrial Engineering ? In what way it helps to improve productivity ? **8**
OR
2. a) What are the ways to increase productivity ? **8**
b) Explain in detail tools and techniques of Industrial Engineering. **8**
3. a) What are the symbols used in method study ? Explain in detail. **8**
b) What is micro motion study ? Explain in detail steps involved in micro motion study. **8**
OR
4. a) Explain in detail string diagram and flow diagram with their applications. **8**
b) Explain in detail multiple activity chart and SIMO chart. **8**
5. a) Explain in detail the steps used in time study. **10**
b) Explain in detail the any two methods of performance rating in time study. **8**
OR
6. a) What are the allowances in work measurement ? Explain in detail. **10**
b) Explain in detail the procedure to carry out stop watch time study to calculate standard time for the job. **8**

P.T.O.



SECTION – II

7. a) Define the term Quality, Quality of design, Quality of performance, Quality of conformance. **8**
- b) A machine is working to a specification of 12.58 ± 0.05 mm. A study of 50 consecutive pieces shows the following measurement.
- | 1 | 2 | 3 | 4 | 5 | 6 | 7 | 8 | 9 | 10 |
|-------|-------|-------|-------|-------|-------|-------|-------|-------|-------|
| 12.54 | 12.58 | 12.61 | 12.57 | 12.57 | 12.58 | 12.60 | 12.65 | 12.60 | 12.65 |
| 12.58 | 12.57 | 12.60 | 12.61 | 12.60 | 12.59 | 12.62 | 12.57 | 12.59 | 12.61 |
| 12.62 | 12.60 | 12.64 | 12.56 | 12.62 | 12.59 | 12.61 | 12.57 | 12.60 | 12.60 |
| 12.56 | 12.60 | 12.58 | 12.59 | 12.61 | 12.56 | 12.67 | 12.56 | 12.63 | 12.62 |
| 12.59 | 12.61 | 12.64 | 12.59 | 12.58 | 12.57 | 12.60 | 12.61 | 12.56 | 12.62 |
- i) Determine the process capability.
 ii) Determine X and R control limits.
 iii) State whether the machine is capable of meeting the tolerances.
 iv) Calculate % defective, if any.
 v) Suggest possible ways by which the percent defective can be reduced.
- Assume :
- i) Normal distribution.
 ii) d_2 for sub-group size 5 is 2.326. **8**
- OR
8. a) Differentiate value of quality and cost of quality. **6**
- b) A manufacturer purchases small bolts in cartons that usually contain several thousand bolts. Each shipment consists of a number of cartons. As a part of the acceptance procedure for these bolts, 400 bolts are selected at random from each carton and are subjected to visual inspection for certain defects. In a shipment of 10 cartons the respective percentages of defective in the samples from each carton are 0, 0, 0.5, 0.75, 0, 2.0, 0.25, 0, 0.25 and 1.25. Does this shipment of bolts appear to exhibit statistical control with respect to the quality characteristic examined in the inspection ? **6**
- c) What do you mean by term process capability and process capability index ? **4**
9. a) Explain Deming's and Juran's approach about total quality management. **8**
- b) Explain with suitable example quality improvement tool six sigma. **8**
- OR
10. a) Discuss any three quality improvement tools. **8**
- b) What do you mean by term reliability ? **4**
- c) What is design of experiments ? What is its objective ? **4**
11. Write short note on (any 3) : **18**
- a) Operating Characteristic Curve (OC).
 b) ISO 9000 series and ISO 14000.
 c) Quality audit and Quality award.
 d) T.S. 16949.



Seat No.	
----------	--

**T.E. (Production) (Semester – II) Examination, 2014
MACHINE TOOLS ENGINEERING
(2008 Course)**

Time : 3 Hours

Max. Marks : 100

- Instructions :** 1) Answers to the **two** Sections should be written in **separate** answer books.
2) Answer **any three** questions from **each** section.
3) Figures to the **right** side indicate **full** marks.
4) Neat diagram must be drawn **wherever** necessary.
5) **Use** of non programmable calculator is **allowed**.
6) Assume suitable data if **necessary**.

SECTION – I

1. Design and draw cam profile for the component shown in figure below. Also work out the following requirements. 18
- a) Sequence of operation
 - b) Table for cam angle and cycle time
 - c) Cam profile for turret operation.

Data given-Cutting speed - 35 M/min, Feed 0.2 mm/rev, Work piece – MS.

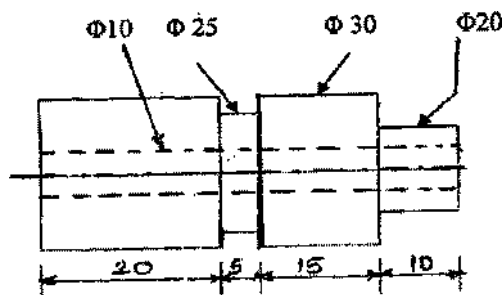

OR

- 2. a) Explain difference between automatic and semi automatic machine and write difference between capstan and turret lathe. 9
- b) With the help of neat diagram, explain the bar feeding mechanism for automatics. 9
- 3. a) Discuss absolute and incremental positioning system. 8
- b) Explain the concept of Direct Numerical Control (DNC). Clarify how it can improve the overall performance of a manufacturing unit. 8

OR



- 4. a) How NC/CNC machines are classified with different considerations ? Explain with neat block diagram NC and CNC machines. 8
- b) What do you understand by axes designation in NC machines ? Describe motion direction on five axes milling machine. 8
- 5. a) Define material handling. Explain principles of material handling. 8
- b) Write short note on Automated Guided Vehicle System (AGVS). 8

OR

- 6. a) Classify material handling equipments with example. 8
- b) Write short note on Automated Storage and Retrieval System (AS/RS). 8

SECTION – II

- 7. a) Compare EBM and LBM for the following points. 8
 - i) Environment
 - ii) Beam Production
 - iii) Beam Focusing
 - iv) Focal Point Traverse.
- b) Suggest suitable unconventional process for the following application and justify it. 8
 - i) Aperture drilling for electronic microscope.
 - ii) Sharpening of carbide tips and tools
 - iii) Drilling small deep holes in nozzles.

OR

- 8. a) Suggest suitable process for following applications with proper justification in unconventional machining. 8
 - i) Holes with curved axis of any shape in glass.
 - ii) Profile cutting of heavy super alloy plates
 - iii) Grinding profile parts such as honey comb.
- b) Explain the process Plasma Arc Machining in brief. 8



9. a) Explain the installation as well as maintenance procedures adopted for machine tools. **8**
b) State the function and requirements of control system in machine tools. **8**

OR

10. a) Discuss preventive and break down maintenance in detail. **8**
b) Explain the installation as well as maintenance procedures adopted for machine tools. **8**
11. a) Explain in brief with neat sketch any two processes used to finishing of spur gear. **9**
b) Explain with neat sketch the setup working of Hobbing machine for cutting a spur gear.
Show setting of Hob in the above case for the Hob having Right Hand helix and Left Hand helix. **9**

OR

12. a) Explain with neat sketch a bevel gear generating process along with advantages. **9**
b) Write note on Worm Wheel by Hobbing. **9**



[4658] – 66

Seat No.	
-------------	--

**T.E. (Semester – II) (Electrical) Examination, 2014
ENERGY AUDIT AND MANAGEMENT
(2008 Course)**

Time : 3 Hours

Max. Marks : 100

- Instructions :** 1) Answers to the **two** Sections should be written in **separate** books.
2) **Neat** diagrams must be drawn **wherever** necessary.
3) **Black** figures to the **right** indicate **full** marks.
4) **Use** of logarithmic tables, slide rule, Mollier charts, electronic pocket calculator and steam tables is **allowed**.
5) Assume **suitable** data, **if necessary**.

SECTION – I

1. a) Explain salient features of Electricity Act, 2003. 8
b) Explain in details various energy sources.
 a) Primary and secondary energy sources.
 b) Conventional and non-conventional energy sources. 10
 OR
2. a) Explain importance of energy conservation and impact on environment. 8
b) What is Green Building ? Explain salient features of Energy Conservation Building Code. 10
3. a) Discuss in detail the various barriers in implementing Demand Side Management. 8
b) What are the duties of Energy Manager ? 8
 OR
4. a) Explain use of DSM to control the agricultural and domestic load. 8
b) Explain the general structure of energy management in an industry. 8
5. a) Explain the following concepts :
 a) Sankey Diagram
 b) CUSUM technique. 8
b) List various instruments and state their use in carrying out energy audit. 8
 OR
6. a) Explain in brief various types of energy audits. 8
b) Discuss typical energy audit report format. 8

P.T.O.



SECTION – II

7. a) Explain tariffs based on power factor. Will implementation of such a tariff help in loss reduction. **8**
- b) Determine the simple back period of the investment for two transformer catering following load

	Option A	Option B
Capacity	315 kVA	315 kVA
Efficiency at rated capacity	98%	99%
Capital cost	Rs. 2.2 lacs	Rs. 3.0 lacs
Operating power factor	0.9 lag	0.9 lag
No load losses	Same for both units	

Energy charges Rs. 4.5/kWh for analysis consider following cases.

- i) 10 hours/day and 250 days/year of operation
- ii) 16 hours/day and 300 days/year of operation. **10**

OR

8. a) For a utility conservative project an investment of Rs. 10 lacs is required. The revenue generation for five years from the project estimated to be Rs. 2 lacs, 2 lacs, Rs. 3 lacs, Rs. 3 lacs and Rs. 3.5 lacs. Calculate internal rate of return from following discounting factors 10%, 12% and 14%. **10**
- b) Explain criteria for financial appraisal of an investment in power project. Also enumerate benefits of net present value method. **8**
9. a) Explain term ILER and its implications in energy conservation. Also explain role of control gears in energy conservation in lighting systems. **8**
- b) Discuss various heat losses taking place in furnaces and methods to minimizing these losses. **8**

OR

10. a) Discuss energy conservation opportunities in fans and blowers. **8**
- b) Write notes on : **8**
- i) Energy efficient compressors
- ii) Selection criteria for DG sets.
11. a) Discuss various alternatives for reduction of power theft in Indian power distribution network. **8**
- b) In a large multiplex energy audit is carried out suggest suitable measures for reduction in energy bills in illumination, central air conditioner and DG sets. **8**

OR

12. a) Explain feasible energy saving options for Municipal Corporations. **8**
- b) Explain energy audit case study of a thermal power plant. **8**



[4658] – 68

Seat No.	
-------------	--

T.E. (Electrical) (Semester – II) Examination, 2014
DESIGN OF ELECTRICAL MACHINES
(2008 Course)

Time : 3 Hours

Max. Marks : 100

- Instructions :** 1) Answer **3** questions from Section I and **3** questions from Section II.
2) Answers to the **two** Sections should be written in **separate** books.
3) **Neat** diagrams must be drawn **wherever** necessary.
4) **Black** figures to the **right** indicate **full** marks.
5) **Use** of logarithmic tables slide rule, Mollier charts, electronic pocket calculator and steam tables is **allowed**.
6) Assume suitable data, **if necessary**.
7) **All** questions are **compulsory**.

SECTION – I

1. a) Explain the differences between electric circuit and magnetic circuit. What is the magnetic leakage in magnetic circuit ? Define magnetic leakage coefficient. How the performance of ac machines depend on leakage Flux of magnetic circuit ? 10
- b) Explain the concept of “Real and Apparent Flux Densities” over the one slot pitch of ac machine. Consider the slots are parallel sided. 8

OR

2. a) Sketch the paths of the following leakage fluxes in relation to a 3-phase induction motor
- i) Slot leakage flux
 - ii) Zig-zag leakage flux
 - iii) Tooth-top leakage flux
 - iv) Overhang leakage flux. 8
- b) Calculate the mmf required for the air-gap of a machine having core length = 0.32 m including 4 ducts of 10 mm each, pole arc = 0.19 m, slot pitch = 65.4 mm, slot opening = 5 mm, air-gap length = 5 mm, flux per pole = 52 mwb. Given Carter’s coefficient is 0.18 for opening/gap = 1 and is 0.28 opening/gap = 2. 10
3. a) Explain the hydrogen cooling system used for turbo-generators. Write the advantages of hydrogen cooling system. 8
- b) Derive the equation for output of single phase transformer. Why the rating of the transformer is mentioned in KVA or MVA ? 8

OR

P.T.O.



4. a) Explain the construction of magnetic core of modern core type power transformers. Explain the significance of mitred joints in construction of core. **8**
- b) A 200 KVA, 6600/440 V, 3-phase, 50 Hz Delta/star core type transformer has the following particulars. Max. flux density = 1.3 wb/m^2 , current density = 2.5 A/mm^2 , window space factor = 0.3, overall height = overall width. Window area = $1 \frac{1}{4}$ times core area, assume 3-stepped core. Calculate the overall core dimensions. **8**
5. a) Explain the procedure to calculate the no-load current in single phase core type transformer. **8**
- b) Calculate the leakage reactance of a 50 Hz transformer with the following data.
Mean length of primary turn = 1.2 m, No. of primary turns = 500, mean length of secondary turns = 1.0 m, No. of secondary turns = 20. Thickness of each winding = 0.025 m, width of duct = 0.014 m, height of each winding = 0.60 m. **8**

OR

6. a) Derive the expression for mechanical force (F_r) developed in oil immersed transformer under short circuit condition. How the windings are designed to withstand the forces in transformer. **8**
- b) Design an adequate cooling arrangement for a 250 KVA, 6600/400 V, 50 Hz, 3-phase, delta/star core type oil immersed natural cooled transformer with the following particulars.
- Winding temp. rise not to exceed 50°C
 - Total loss at 90°C are 5 kW
 - Tank dimensions, height \times length \times width = 125 cm \times 100 cm \times 50 cm
 - Oil level = 115 cm length
- Draw the diagram showing the arrangement of cooling tubes. **8**

SECTION – II

7. A) Derive the Output equation of 3 ph. IM. State the units with meanings of each symbol used. **8**
- B) Determine the main dimensions, turns per phase, number of slots, conductor cross-section and slot area of a 250 hp, 3-phase 50 Hz, 400 v, 1410 rpm slip ring induction motor. Assume $B_{av} = 0.5 \text{ wb/m}^2$, $a_c = 30,000 \text{ A/m}$, efficiency = 0.9 and power factor = 0.9, winding factor = 0.955, current density = 3.5 A/mm^2 . Slot space factor = 0.4 and ratio $L/\tau = 1.2$. The machine is delta connected assume 5 slots per pole per phase. **10**

OR

8. A) With reference to ac windings compare :
- Single layer and double layer winding
 - Fractional slot and integral slot winding. **8**
- B) Discuss factors governing choice of specific electrical loading and specific magnetic loading for 3 ph. IM. **10**



9. A) Discuss factors that affect the choice of length air gap in IM. Why should air gap be as small as possible ? 8
- B) A 90 kw, 500 v, 50 Hz, 3-phase, 8-pole induction motor has a star connected stator winding accommodated in 63 slots with 6 conductors per slot. If the slip-ring voltages on open circuit is to be about 400 V, find a suitable rotor winding, stating :
- i) Number of slots
 - ii) Number of conductors per slot
 - iii) Coil span
 - iv) Slip ring voltage on open circuit
 - v) Approximate full load current per phase in rotor.
- Assume efficiency = 0.9, power factor = 0.86, slots per pole per phase = 3, rotor mmf is 86% of stator mmf. 8
- OR
10. A) Explain various methods to eliminate harmonic torques. 8
- B) Derive the equation for end ring current of squirrel cage IM. 8
11. A) Discuss various losses in case of 3 ph. IM. 8
- B) Explain methods for improving starting torque of Induction motor. 8
- OR
12. A) A 75 kw, 3300 v, 50 Hz, 8-pole, 3 phase star connected induction motor has a magnetizing current which is 35% of the full load current. Calculate the value of stator turns per phase if the mmf required for flux density at 30° from pole axis is 500A. Assume winding factor = 0.95, and full load efficiency and power factor 0.94 and 0.86 respectively. 8
- B) Write short notes on : 8
- a) MMF calculations for air gap of 3 phase Induction motor
 - b) Effect of saturation on calculation of mmf of 3 phase Induction motor
 - c) Performance calculations of 3 ph. IM from circle diagram.



[4658] – 7

Seat No.	
-------------	--

T.E. (Civil) (Semester – II) Examination, 2014
FOUNDATION ENGINEERING
(2008 Course)

Time : 3 Hours

Max. Marks : 100

- Instructions :** 1) Answer **three** questions from Section I and **three** questions from Section II.
- 2) Answers to the **two** Sections should be written in **separate** books.
- 3) **Neat** diagrams must be drawn **wherever** necessary.
- 4) Black figures to the **right** indicate **full** marks.
- 5) Your answers will be valued as a **whole**.
- 6) **Use** of logarithmic tables, slide rule, Mollier charts, electronic pocket calculator and steam tables is **allowed**.
- 7) **Assume** suitable data, if necessary.

SECTION – I

1. a) i) What are the factors that influence the depth and number of exploratory holes.
- ii) What is significant depth ? **(4+2)**
- b) Write a detailed note on standard penetration test. **5**
- c) The inner diameters of sampling tube and that of cutting edge are 70 mm and 68 mm respectively. Their outer diameters are 72 mm and 74 mm respectively. Determine inside clearance, outside clearance and area ratio of the sampler. **6**

OR

2. a) i) Differentiate between DCPT and SCPT.
- ii) What are the factors that effect the sample disturbance ? **(3+3)**
- b) Explain 'Electrical Resistivity Method' for subsurface exploration. **5**
- c) Write a note on 'Pressure Meter Test'. **6**

P.T.O.



3. a) Explain the effect of submergence of bearing capacity for different positions of ground water table. **6**
- b) Explain Skempton's analysis of determination of bearing capacity of clayey soil. **6**
- c) Compute the safe bearing capacity of a continuous footing 1.8 m wide, and located at a depth of 1.2 m below ground level in a soil with unit weight $\gamma = 20 \text{ kN/m}^3$, $C = 20 \text{ kN/m}^3$, and $\phi = 20^\circ$. Assume a factor of safety of 2.5 Terzaghi's bearing capacity factors are $N_c = 17.7$, $N_q = 7.4$ and $N_r = 5.0$. **6**

OR

4. a) Explain presumptive bearing capacity and floating foundation. **(3+3)**
- b) Write a note on 'plate load test'. **6**
- c) A foundation 2.0 m square is installed 1.2 m below the surface of a uniform Sandy gravel having a density of 19.2 kN/m^3 , above the water table and a submerged density of 10.1 kN/m^3 . The strength parameters with respect to effective stress are $C' = 0$ and $\phi' = 30^\circ$. Find the gross ultimate bearing capacity for the following conditions.
- Water table is well below the base of the foundation.
 - Water table rises to the level of base of the foundation; and
 - The water table rises to ground level. **6**
5. a) Differentiate between 'total settlement and 'differential settlement'. What are the harmful effects of differential settlement on structures ? **4**
- b) Explain any one method of determining pre consolidation pressure. **5**
- c) In a consolidation test void ratio decreased from 0.70 to 0.65 when the load was changed from 50 kN/m^2 to 100 kN/m^2 . Compute compression index and coefficient of volume change. **6**

OR

6. a) Define the following :
- Compression index
 - Coefficient of volume compressibility
 - Coefficient of compressibility
 - Coefficient of consolidation. **4**
- b) What is 'contact pressure' ? How does it depend on the type of structure and type of soil ? **5**
- c) For a clayey soil what will be the settlement for rigid rectangular footing $2 \text{ m} \times 3 \text{ m}$ if elastic parameters $E_s = 8000 \text{ kN/m}^2$, $\mu = 0.35$ $I_s = 0.785$ and under a load of 600 kN ? How will the settlement be affected if footing is flexible ? (Assume $I_s = 1.2$ for flexible). **6**



SECTION – II

7. a) Write the effect of negative skin friction on pile foundation and the measures to reduce it. **6**
b) Explain with sketches the following types of Caisson foundations. **6**
 i) Open type ii) Box type
c) A group of 16 piles of 50 cm diameter is arranged with a centre to centre spacing of 1.0 m. The piles are 9 m long and are embedded in soft clay with cohesion 30 kN/m^2 . Bearing resistance may be neglected for the piles – Adhesion factor is 0.6. Determine the Ultimate load capacity of the pile group. **6**

OR

8. a) Determine the efficiency of pile group of 4 piles in 2 rows using Converse Labarre formula and using Feld's rule having arc tan value of 18.3. **6**
b) Explain with figures the following difficulties and their rectification **6**
 i) Tilt ii) Hanging up
c) Explain the adverse effects of pile driving. **6**
9. a) Discuss any 3 types of cofferdams with its importance. **6**
b) Draw a neat sketch of double under-reamed pile and explain how would you decide its load bearing capacity. **6**
c) Explain the preloading technique with a neat sketch. **4**

OR

10. a) Derive an expression for depth of embedment of cantilever pile by making simplified assumptions. **6**
b) Explain the construction procedure for under-reamed piles with sketches. **6**
c) Explain differential free swell index test. **4**
11. a) Enumerate the factors influencing ground motion. **6**
b) What is reinforced earth wall ? Draw a neat sketch of reinforced earth wall. **6**
c) Give the various types of geosynthetics used for ground improvement. **4**

OR

12. a) Explain with sketches component of nailed soil wall and its construction. **6**
b) Give the use of geosynthetics as a separator and reinforcement. **6**
c) Explain phenomenon of liquefaction for sandy soils. **4**



[4658] – 8

Seat No.	
-------------	--

**T.E. (Civil) (Semester – II) Examination, 2014
ENVIRONMENTAL ENGINEERING – I
(2008 Course)**

Time : 3 Hours

Max. Marks : 100

- Instructions :** 1) Solve Q. 1 or Q. 2, Q. 3 or Q. 4, Q. 5 or Q. 6 from Section – I and Q. 7 or Q. 8, Q. 9 or Q. 10, Q. 11 or Q. 12 from Section – II.
2) Answers to the **two** Sections should be written in **separate** books.
3) **Neat** diagrams must be drawn **wherever** necessary.
4) Figures to the **right** indicate **full** marks.
5) Use of logarithmic tables, slide rule, Mollier charts, electronics pocket calculator and steam tables is **allowed**.
6) Assume suitable data, if **necessary**.

SECTION – I

1. a) What is demand of water ? What are various demands of a growing town ? Mention these demands per capita basis. 3
- b) How is the quality of water decided ? State the important tests that are carried out in the laboratory under each category. 3
- c) Forecast the future population of a town for the year 2021 by the incremental increase method with the help of following census data : 12

Year	1931	1941	1951	1961	1971	1981	1991
Population	24000	28500	34800	71900	46700	51500	56500

OR

2. a) What are different types of pipes available for use in water supply system ? Discuss merits and limitations of each. 8
- b) Give the standards as per IS 10500 for the following for drinking water. Also state the ill effects if they are in excess. 6
- i) Hardness
 - ii) Chlorides
 - iii) Nitrates
 - iv) Fluorides
 - v) MPN
 - vi) Turbidity
- c) Explain what do you mean by design period and discuss the factors affecting design period. 4

P.T.O.



3. a) What is turbidity ? Why do colloidal impurity requires chemical assistance for settlement ? Explain how alum reacts with water by giving chemical equation. **3**
- b) Why is the aeration used in water treatment plants ? Is it more commonly used with ground water or surface water ? Why ? **3**
- c) A water treatment plant treats $250 \text{ m}^3/\text{hr}$ of water. Workout the following with respect to flocculator. **10**
- Dimensions of flocculator unit.
 - Power input by paddles to water.
 - Size and number of paddles.
- Assume water temp. = 25°C and absolute viscosity = $0.89 \times 10^{-3} \text{ N-S/mt}^2$.
 Detention time = 30 minutes.
 Given that velocity of water in inlet pipe = 1.2 mt/sec Drag coefficient $C_D = 1.8$, $G = 40 \text{ sec}^{-1}$.
 Velocity at tip of paddle = 0.5 mt/sec .

OR

4. a) A water supply scheme is to be designed for a town. Considering perennial river as a source, sketch a complete water supply scheme, showing all the units in plan. State the function of each unit. **6**
- b) Discuss the various techniques of removing taste and odour from water. **4**
- c) Explain the laboratory method for Jar test with its importance. **6**
5. a) Describe with the help of a neat sketch, the component parts of a rapid sand gravity filter. Explain its working, including the method of washing. **10**
- b) Calculate the amount of bleaching powder required in kg/day , for 10 MLD of water. The filtered water exerts a chlorine demand of 0.6 mg/l to leave residual chlorine of 0.2 mg/l . Chlorine available from bleaching powder is 40%. **6**

OR

6. a) What do you mean by disinfection ? Discuss the factors affecting efficiency of disinfection. Enlist at least four disinfectants used in water treatment plant and discuss Breakpoint Chlorination in detail. **6**
- b) The population of a city is 50,000 and per capita consumption is 135 litres/day. Calculate the following with respect to rapid sand filter for the above data : **10**
- Total are of filters
 - Number and dimensions of each filter
 - Depth of sand bed.
- Assume break through index as 4×10^{-4} .

SECTION – II

7. a) Why defluoridation is necessary ? Explain any three methods of defluoridation. **4**
- b) Explain method of treatment of water for swimming pool. **4**
- c) Write short note on : **8**
- Reverse osmosis.
 - Ion exchange method for water softening.

OR



8. a) Explain the process of demineralization. 4
b) Explain the adsorption process for odour and colour removal. 4
c) Write short note on :
1) Water softening by Lime-soda process.
2) Electrodialysis. 8
9. a) Write short note on : Water Leakage Detection Techniques in distribution network. 4
b) The designed demand of a community is 6 MLD; water is pumped into an elevated reservoir from 6 am to 11 pm. The supply to the community is from 6 am to 10 am and 6 pm to 10 pm at a uniform rate. Design the balancing capacity of the reservoir. 8
c) Explain the design steps for roof rain water harvesting system. 6

OR

10. a) Write short note on : Pressure in the distribution system. 4
b) A clear water tank is receiving water from the treatment plant at a rate of 300 m³/hr for 24 hours. The high lift pumps are lifting water from the same tank at the following rates : 4 to 14 hrs @ 270 m³/hr and 15 to 24 hrs @ 500 m³/hr. Determine the capacity required for the clear water tank. 8
c) Explain any three methods of rain water harvesting system. 6
11. a) Explain following terms :
1) Environmental lapse rate
2) Adiabatic lapse rate
3) Unstable atmosphere
4) Stable atmosphere. 4
b) Draw neat sketches and explain plume behaviour under the different atmospheric condition. 6
c) Explain in brief method of calculating resultant noise level when there are number of source of noise exist. 6

OR

12. a) What is inversion ? Explain the subsidence inversion. 4
b) Enlist the various equipment used for controlling air pollution in industries. Explain working principle of fabric filter. 6
c) Write a short note on : Noise Rating System. 6



[4658] – 87

Seat No.	
-------------	--

T.E. (E & TC) (Semester – II) Examination, 2014
SYSTEM PROGRAMMING AND OPERATING SYSTEM
(2008 Course)

Time : 3 Hours

Max. Marks : 100

- Instructions :** 1) Answers to the **two** Sections should be written in **separate** answer books.
2) **Neat** diagrams must be drawn **wherever** necessary.
3) Assume **suitable** data, if **necessary**.

SECTION – I

1. A) What do you understand by Grammar ? Explain the use of terminal and non-terminal in representing grammar. 4
B) Explain any one data structure used for language processing. 4
C) Explain LEX and YACC. 8
OR
2. A) Define following terms and explain where it is used with examples. 8
i) DFA ii) Regular Expression
iii) Forward Reference iv) Back Tracking.
B) Explain different phases of language processing. 10
3. A) What is compiler ? Describe the different phases of compiler in detail. 8
B) Define macro and explain macro expansion with suitable example of nested macro. 10
OR
4. A) Differentiate : Expansion time loops and Execution time loops. 4
B) Explain Positional Parameters, Keyword Parameters and Default Specification of Parameters. 4
C) Explain Data structures of macro preprocessor. 8
5. A) Why program relocation is required and how is it performed ? 6
B) Explain the function of compiler and go scheme. What are the advantages and disadvantages of the scheme ? 10
OR
6. A) Explain the design of a direct linking loader. Also explain all required data structures. 8
B) List down the components of a programming environment. Explain any two components in detail. 8

P.T.O.



SECTION – II

7. A) Explain IPC. Explain different IPC problems. **10**
B) Write short notes on the following : **8**
 i) Process Control Block
 ii) Critical Section
 OR
8. A) Explain deadlock and explain different methods to avoid deadlock. **9**
B) Draw and explain process state transitions. **5**
C) Explain preemptive and non preemptive concept with example. **4**
9. A) Explain the concept of segmentation. **8**
B) How virtual memory system is utilized in memory management ? Explain in detail. **8**
 OR
10. A) Explain the need for paging. **4**
B) Explain the performance of demand paging. **8**
C) Explain advantages and disadvantages of segmentation. **4**
11. A) Explain the following :
 A) File directories
 B) Disk ARM scheduling algorithm. **8**
B) Draw and briefly explain the file structure. **8**
 OR
12. Write short note on : **16**
 1) Clock software
 2) Graphical user interface
 3) File system and implementation with an example.



Seat No.	
----------	--

T.E. (Instrumentation and Control) (Semester – II) Examination, 2014
DIGITAL SIGNAL PROCESSING FUNDAMENTALS
(2008 Course)

Time : 3 Hours

Max. Marks : 100

- Instructions :** 1) Answers to the **two** Sections should be written in **separate** books.
2) **Neat** diagrams must be drawn **wherever** necessary.
3) **Black** figures to the **right** indicate **full** marks.
4) **Use** of logarithmic tables, slide rule, Mollier charts, electronic pocket calculator and steam tables is **allowed**.

SECTION – I

1. a) Define the following with examples : 8
i) Causal and non-causal systems
ii) Static and dynamic systems
iii) Linear and non-linear systems
iv) Time-variant and time-invariant systems.
- b) Find the fundamentals period and state whether the following signals are periodic or non-periodic. 8
i) $x_1[n] = e^{j3\pi n}$
ii) $x_2[n] = \cos\left(\frac{2\pi n}{7}\right) + \cos\left(\frac{2\pi n}{5}\right)$

OR

2. a) Determine the output of an linear time invariant (LTI) if the input to the system is $x[n] = \{3, 2, 1, 1\}$ and its impulse response is $h[n] = \{1, 2, 1, 1\}$. 8
b) Explain the meaning of linear convolution. Also state the properties of linear convolution. 8
3. a) Determine the system function $H(z)$ and its impulse response of the following causal discrete time LTI system :
$$y[n] = \frac{3}{4}y[n-1] + \frac{1}{8}y[n-2] - x[n]$$

where $x[n]$ = input of the system, and
 $y[n]$ = output of the system. 8
- b) Realize the following difference equation using Direct form I and Direct form II structure
$$y[n] = y[n-1] - \frac{1}{2}y[n-2] + x[n] - x[n-1] + x[n-2]$$
 8

OR

P.T.O.



4. a) Draw the
 i) Direct form I and
 ii) Direct form II structures for the following filter function :

$$y[n] = \frac{-1}{10}y[n-1] + \frac{7}{10}y[n-2] + 0.6x[n] - \frac{1}{5}x[n-2]$$
 8
 b) Plot the magnitude and phase response of the system described by

$$y[n] + 0.5y[n-1] = x[n] - x[n-1]$$
 8
5. a) Determine the circular convolution of $x[n] = \{1, 2, 3, 4\}$ and $y[n] = \{4, 3, 2, 1\}$. 8
 b) Explain any four properties of Discrete Fourier Transform (DFT). 8
 OR
6. a) State and prove any two properties of Discrete Fourier Transform (DFT). 8
 b) Determine 8-point DFT of the following sequence $x[n] = \left\{ \frac{1}{2}, \frac{1}{2}, \frac{1}{2}, \frac{1}{2} \right\}$. 8

SECTION – II

7. a) Describe the 8-point DIT FFT algorithm. 8
 b) Determine 8-point DFT of $x(n) = \{1, 1, 1, 1\}$ using DIT FFT algorithm. 8
 OR
8. a) Explain the 8-point DIF FFT algorithm. 8
 b) Determine the 8-point DFT of signal $x(n) = 1 + \cos(2\pi n)$ using DIF FFT algorithm. 8
9. Design a low-pass FIR filter for cut-off Freq. = $\pi/6$ rad/sample, length $M = 7$. Use the following window functions :
 a) Rectangular b) Triangular
 c) Hamming d) Hanning 18
 OR
10. a) What are the different methods of FIR filter design ? Compare FIR filter and IIR filter. 9
 b) Design a high-pass FIR filter for cut-off Freq. = $\pi/6$, length $M = 7$. Use Rectangular window. 9
11. a) Explain Bilinear Transformation and impulse invariance methods in detail. 8
 b) Obtain the digital transfer function from $H_a(s) = \frac{1}{s+2}$ using bilinear transformation. 8
 OR
12. a) Obtain the transfer function for a Butterworth Filter (low-pass) with cut-off Freq. = 0.707 rad/sec. Order $N = 3$. Using impulse invariance method convert the analog filter to digital filter. 8
 b) Write short note on : 8
 1) Impulse invariance method 2) Bilinear transformation.



[4658] – 107

Seat No.	
-------------	--

T.E. Printing (Semester – II) Examination, 2014
STATISTICAL PROCESS CONTROL
(2008 Course)

Time : 3 Hours

Max. Marks : 100

- Instructions :**
- 1) **All** questions are **compulsory**.
 - 2) Assume suitable data, if **necessary**.
 - 3) Answers to the **two** Sections should be written in **separate** books.
 - 4) Neat diagrams must be drawn **wherever** necessary.
 - 5) Black figures to the **right** indicate **full** marks.
 - 6) Use of logarithmic tables slide rule, Mollier charts, electronic pocket calculator and steam tables is **allowed**.

SECTION – 1

1. A) Explain Brainstorming and check sheet tools used in SPC. 8
B) Explain the concept of Quality with reference to Detection Technique and Prevention Technique in detail with suitable example. 8
- OR
1. Decide the basic symbols and their interpretations and prepare a flowchart for the make ready operations on offset machine. 16
2. A) Explain Histogram in short. 4
B) Explain the various Histogram patterns in short with diagrams and its probable causes. 12
- OR
2. From the given data, arrange the data, prepare frequency distribution table and draw the Histogram only and comment on the same. 16

0.912	0.910	0.904	0.905	0.910	0.911
0.914	0.912	0.910	0.913	0.908	0.914
0.907	0.909	0.913	0.912	0.909	0.913
0.902	0.906	0.909	0.907	0.906	0.908
0.915	0.909	0.910	0.911	0.912	0.909
0.910	0.909				

Note 1: From G Chart, the recommended number of groups should be 7 for number of measurements between 30 to 40.

P.T.O.



- 3. A) Explain process variation concept. And also types of variations with diagram and suitable examples. 10
- B) Explain the concept of distribution of measurement data with reference to the characteristics of distribution. 8

OR

- 3. A) With example, explain the term 'Mean, Median and Mode' along with their advantages and disadvantages. 10
- B) Explain the Measures of Distribution and its application in Statistical Process Control with suitable examples. 8

SECTION – 2

- 4. Prepare X-MR chart from the given data. 16

Sample No.	1	2	3	4	5	6	7	8	9	10
Measurements	.0218	.0243	.0232	.0256	.0247	.0255	.0282	.0261	.0244	.0252

Sample No.	11	12	13	14	15	16	17	18	19	20
Measurements	.0265	.0267	.0254	.0238	.0249	.0275	.0265	.0232	.0294	.0281

Note : Use n = 2

Shewart's Constants: $E_2 = 2.659$

$D_3 = 0$

$D_4 = 3.3$

OR

- 4. Prepare X bar R chart from the given data on graph paper. 16

Sample No.	1	2	3	4	5	6	7	8	9	10
Measurements	933	911	889	882	903	890	892	908	895	916
	897	898	915	913	930	940	912	920	920	890
	885	900	905	930	890	895	895	896	922	891
	900	905	902	900	890	909	896	894	928	920
	879	862	873	871	900	915	902	906	926	915

Note : Take fractional values only up to two digits

Shewart's Constants : $A_2 = 0.577$

$D_3 = 0$

$D_4 = 2.1$



5. Make two Pareto Charts for the data in the following list, one for the number of defectives and one for dollar loss. In each case, include a cumulative percentage graph. **16**

Department	Defectives	Dollar Loss
A	20	100
B	120	60
C	80	850
D	100	550
E	50	250
F	30	90

OR

5. Comment on the following : **16**
- a) Cause and Effect Analysis
 - b) Scatter diagram
6. Explain the concept of DOE, and its various applications with suitable examples from printing industry. **18**

OR

6. Explain in detail Cp and Cpk Analysis with suitable diagrams. **18**



5. a) Design cylindrical storage vessel with conical roof and flat bottom having following data :
- Diameter of vessel = 24 m
 - Superimposed load = 1225 N/m²
 - Tank height = 16 m
 - Specific gravity of liquid = 1.05
 - Permissible stress = 140 N/mm²
 - Density of material = 7.7 kg/cm³
 - Modulus of elasticity = 2×10^5 N/mm²
 - Poisson ratio = 0.3
- Design should include :
- i) Shell (size and arrangement of shell plates)
 - ii) Conical roof and
 - iii) Bottom Design. 12
- b) Explain various losses during storage of volatile liquids. 4
- OR
6. a) Explain the stresses developed in the walls of high pressure vessel. 4
- b) Explain shrink fit construction for high pressure vessels. 4
- c) A high pressure vessel is to be operated at 100 MN/m². The inside diameter of the vessel is 30.5 cm. Steel having yield stress 466 MN/m² is selected for fabrication. Estimate the wall thickness required by various theories with factor of safety 1.6. 8

SECTION – II

7. a) A tall vertical 1.5 m in diameter and 13 m high is to be provided with the skirt support. Weight of the vessel with all its attachments is 80,000 kg. Diameter of skirt is equal to the diameter of the vessel. Height of skirt is 2.2 m. Wind pressure tensile stress of skirt material = 960 kg/m², permissible compressive stress is $\frac{1}{3}$ rd yield of material. Yield stress is 2400 Kg/cm² estimate the thickness of skirt support. 10
- b) Give the procedure for the design of saddle supports for a horizontal vessel. Explain all the terms used. 6
- OR
8. a) What are the various stresses developed in the tall vessels ? 6
- b) Why do we need to support vessels ? What are different types of supports and when do we use the different types ? Draw simple sketches. 10
9. a) A shell and tube heat exchanger is to be constructed with 2.54 cm OD tube. The cold fluid is flowing through the tubes at the rate of 18000 kg/hr. The inlet temperature is 35°C while outlet temperature of cold water is 65°C. The hot water flows outside the tube at the rate of 12800 kg/hr and entering at 100°C. The average velocity of the cold water through the tube is 0.3 m/sec and overall heat transfer coefficient is 1600 w/m² K. Surface area/unit length = 0.0798 m²/m per tube, cross sectional area = 0.0003098 m² per tube. Determine the number of tubes and required length of the tubes for 1 – 1 shell and tube heat exchanger. 12
- b) What is temperature correction factor ? How is it calculated ? Why is it used in design of heat exchanger ? 6

OR



10. a) Why are baffles and tie rods used in shell and tube heat exchangers ? Explain with neat sketch various types of baffles. 6
- b) A heat exchanger with installed heat transfer surface area of 8.1 m^2 is to be used for heating process liquor available at 16.5°C . The heating is to be performed with water available at 93°C from another part of plant. The arrangement of unit is such that the fluids flow in true counter-current manner. The flow rates of the process liquor and water are 3.1 and 1.1 kg/sec respectively. Previous experience indicates that an overall heat transfer coefficient of $450 \text{ W/m}^2 \text{ K}$ is suitable. Estimate the exit temperature of the two fluids and determine the effectiveness of the heat exchanger. 12
11. a) A standard vertical tube evaporator is used to concentrate 6% NaNO_3 solution to 30% solution. The product rate is 6000 kg/hr. The feed enters the evaporator at its boiling point corresponding to a pressure of 0.68 atm. Steam is available at 3.5 atm. If the overall heat transfer coefficient is $2550 \text{ W/m}^2\text{K}$, determine the heat transfer area required.
- The specific heat of feed and products are 3768 and $3894 \text{ J/Kg}^\circ\text{K}$ respectively. Neglect the effect of hydrostatic heat and boiling point rise. Also determine steam consumption per hour. 12
- b) Explain the advantages, disadvantages and applications of plate heat exchanger. 4
- OR
12. Design 1–4 shell and tube condenser for condensation of Ammonia vapors. Following design data is given :
- Saturation temperature of ammonia vapors = 42°C
 - Flow rate of vapors = 0.3 kg/sec
 - Water is available at 28°C
 - 25 mm OD tubes are arranged on triangular pitch of 31 mm and tube length is 5.0 m
 - Overall heat transfer coefficient for condensing vapors = $1800 \text{ W/m}^2\text{K}$
 - Fouling factor on ammonia side = $0.0002 \text{ [W/m}^2 \text{ K]}^{-1}$
 - Fouling factor on water side = $0.0004 \text{ [W/m}^2 \text{ K]}^{-1}$
- Properties of liquid ammonia :
- Density = 600 kg/m^3
 - Viscosity = $0.085 \times 10^{-3} \text{ N.sec/m}^2$
 - Thermal conductivity = 0.052 W/m K
 - Latent heat of ammonia vapors = 1092 kJ/kg
- Properties of water :
- Density = 1000 kg/m^3
 - Viscosity = $0.7 \times 10^{-3} \text{ N.sec/m}^2$
 - Thermal conductivity = 0.63 W/m K . 16
-



[4658] – 126

Seat No.	
-------------	--

T.E. (Petroleum Engineering) (Semester – II) Examination, 2014
PETROLEUM GEOLOGY – II
(2008 Course)

Time : 3 Hours

Max. Marks : 100

- Instructions :**
- 1) Answers to the **two** Sections should be written in **separate** books.
 - 2) Question no. **5** of Section **I** and Question no. **10** of Section **II** is **compulsory**. Solve any other **two** questions from remaining from **each** Section.
 - 3) Figures to the **right** indicate marks.
 - 4) Draw **neat** diagrams **whenever** necessary.

SECTION – I

1. Answer **any five** terms of the following. **15**
 - a) Natural gases and their dominant modes of formation
 - b) Non-hydrocarbon gases
 - c) Stability fields of gas hydrates
 - d) Heterocompounds
 - e) Types of subsurface water
 - f) Geothermal Gradient
 - g) Lithostatic and Hydrostatic pressure.

OR
2. What are hydrocarbons ? Give important chemical and physical properties of crude oil and natural gas. **15**
3. Give a generalized outline of transformation of organic matter into hydrocarbons with the help of a neat diagram. Explain the role of important factors influencing this change. **15**

OR
4. Explain the source rock, reservoir rock and migration of hydrocarbons using suitable examples. **15**
5. Write in brief on **any two** of the following. **20**
 - a) Causes of Abnormal Pressure
 - b) Sand Shale Depositional System
 - c) Stratigraphic Traps
 - d) Effective Sealing Mechanisms
 - e) Kerogen types from Rock Evaluation Process.

P.T.O.



SECTION – II

6. a) Draw a cross sectional view of a sedimentary basin showing genetic increment of strata. **5**
b) Draw and explain characteristic of **any two** depositional system from below. **10**
1) Delta
2) Meandering river
3) Dunes

OR

7. Write in brief about spatial and temporal occurrence of hydrocarbons. **15**
8. How structure contour maps and Isochore maps provide reliable information on subsurface geology ? **15**

OR

9. Describe Petroleum system of **any one** of the hydrocarbon producing basins of India. **15**
a) Cambay Basin
b) Krishna Godavari Basin
c) Mumbai High Basin
10. Write in brief **any two** of the following. **20**
a) Non-conventional hydrocarbon resources
b) Geological heterogeneities
c) Heat flow analysis in sedimentary basin
d) Sources of subsurface data
e) Importance of cutting samples.



[4658] – 127

Seat No.	
-------------	--

**T.E. (Petroleum Engineering) (Semester – II) Examination, 2014
RESERVOIR ENGINEERING – I
(2008 Course)**

Time : 3 Hours

Max. Marks : 100

- Instructions :** 1) Answer **three** questions from **each** Section.
2) Question no. **4** and Q.No. **8** are **compulsory**.
3) Neat diagrams must be drawn **wherever** necessary.
4) Figures to the **right side** indicate **full** marks.
5) Assume **suitable** data **if necessary**.

SECTION – I

1. a) What is reservoir engineering and how are its objectives accomplished ? **8**
b) Explain the significance of material balance equation in reservoir performance prediction. **8**
2. Derive material balance equation for a reservoir producing with a combination of gas cap drive and water drive mechanism. **16**
3. a) Draw and explain the use of p/z graph. **4**
b) Explain in detail classification of reserves and how are they calculated ? **6**
c) Differentiate between identification characteristics of depletion drive and water drive reservoirs. **6**
4. State the different equations for decline curves. Derive the equations for finding cumulative oil in place for each. **18**

SECTION – II

5. Derive the diffusivity equation in Cartesian coordinate system. Assume gas (a compressible fluid) flows through the porous media. **16**
6. For a pressure build up test explain the terms ETR, MTR and LTR on a Horner's plot, log-log plot and on the derivative plot. **16**
7. a) Give five examples of pressure derivative plots for different reservoir models and explain. **10**
b) What is pseudo reduced pressure ? Explain its use. **6**
8. a) Explain effect of rock properties and fluid properties on reservoir performance. **9**
b) Explain in detail techniques for estimating initial oil and gas in place. **9**



[4658] – 136

Seat No.	
-------------	--

T.E. (Petrochemical) (Semester – II) Examination, 2014
PETROCHEMICAL PROCESSES – II
(2008 Course)

Time : 3 Hours

Max. Marks : 100

- Instructions :**
- 1) Answer **3** questions from **each** Section.
 - 2) Answers to the **two** Sections should be written in **separate** answer books.
 - 3) Figures to the **right** indicate **full** marks.
 - 4) Use of logarithmic tables, slide rule, Mollier charts, electronic pocket calculator and steam table is **allowed**.
 - 5) Assume suitable data, **if necessary**.

SECTION – I

1. a) What is catalytic cracking ? Give its significance. Also discuss the various types of catalytic cracking processes. 10
- b) What are the various methods of sulphur recovery in a refinery ? Discuss any one in detail. 8

OR

2. a) What does the term 'Bottom of the Barrel' mean in a refinery ? Explain the process of delayed coking. 10
- b) What is bitumen ? Give the composition and applications of the same. 8
3. a) Explain the significance of introduction of steam to the furnace inlet of VDU. 4
- b) Explain the need for desalting of crude. 4
- c) Write a note on the atmospheric topping unit. 8

OR

4. a) Differentiate between HF and H₂SO₄ alkylation process. 8
- b) What are the important properties considered for lube oil base stock ? Explain. 8
5. a) What are the various components present in petroleum ? Explain. 8
- b) What are the low boiling products in a refinery ? 8

OR

6. a) Draw a neat labeled diagram of the overall refinery flow. 4
- b) Enlist the various non-conventional sources of energy. 4
- c) Define : API gravity, Viscosity gravity constant, Cloud point, Pour point. 8

P.T.O.



SECTION – II

7. a) Explain the semi regenerative process for catalytic reforming. **8**
b) Write a note on xylene isomerisation. **8**

OR

8. a) Explain a typical process of catalytic reforming ? What are the typical feed stocks to the catalytic reformer ? **8**
b) Explain the importance of hydrogen in a refinery. Discuss in brief the methods of generation and recovery of hydrogen. **8**
9. a) Describe in brief the manufacture of melamine formaldehyde resin. **8**
b) Describe in brief the various characteristics of polymers. **8**

OR

10. a) Write a note on addition and condensation polymerization. **8**
b) Describe the Union Carbide processes for the manufacture of polypropylene. **8**
11. a) Write a note on the various routes of manufacture of adipic acid. **9**
b) Describe the process of manufacture of polyester from DMT. **9**

OR

12. a) Give the process steps involved in the manufacture of nylon-66 with a flow diagram. **9**
b) Give the various routes for the manufacture of polyethylene terephthalate (Polyester fibre). **9**



Seat No.	
-------------	--

T.E. (Petrochemical) (Semester – II) Examination, 2014
MASS TRANSFER – II
(2008 Course)

Time : 3 Hours

Max. Marks : 100

- Instructions :** 1) Attempt **any three** questions from **each** Section.
2) Answer to the **two** Sections should be written in **two separate** answer books.
3) Figures to the **right** indicate **full** marks.
4) Assume suitable data **wherever** necessary.
5) **Use** of steam tables and electronic calculator is **allowed**.

SECTION – I

1. Feed to distillation column consists of 40 Mol% Benzene and the rest toluene. The column is supposed to recover 98% of benzene in feed at the purity specification of 99 Mol%. For 1000 Kmol/hr of 80% saturated liquid feed. **18**
 - a) Calculate distillate and bottoms stream rates and their molar compositions.
 - b) Assuming relative volatility of benzene as 3.0 with respect to toluene, calculate minimum reflux ratio. What operating reflux ratio will you use ?
 - c) Calculate the number of theoretical stages required and the optimum feed plate location.
 - d) Calculate the vapor and liquid traffic in rectifying and stripping sections in Kmol/hr.
2. With reference to flash distillation, answer the following : **16**
 - a) Why is it called an equilibrium distillation ?
 - b) A feed to flash vessel consists of mixture of A (60 Mol%) and B (40 Mol%) at the flow rate of 1000 Kmol/hr. Temperature and pressure of the flash chamber are such that V/L ratio for the streams emerging from the chamber is 1:1. Assuming relative volatility of A as 2.33 with respect to B, calculate the product stream flow rates and their compositions.
3. With reference to steam distillation, answer the following : **16**
 - a) Report degrees of freedom.
 - b) Deduce the basic governing equation.
 - c) Draw a pertinent sketch, suitably labelled, describing the graphical procedure to solve the governing equation.
 - d) At the operating steam distillation temperature, vapor pressures of water and the heavy organic (MW 175) are 720 mm Hg and 40 mm Hg respectively. What will be the minimum steam consumption in Kg per Kg of organic recovered ?

P.T.O.



4. Write precise notes (**not** more than **ten** lines **each**) : **16**
- a) Modified Raoult's Law
 - b) Azeotropy
 - c) Operating reflux ratio.

SECTION – II

5. Calculate the number of actual trays required for the absorber designed for removing organic vapors from a gas. Feed gas flow rate is $1.0 \text{ m}^3/\text{s}$ at NTP and contains 4% by volume organic vapors. Expected recovery is 98%. Solvent (MW 200) fed counter-currently is pure and is fed at the rate of 1.5 times the minimum. Henry's law statement is given as : $y = 0.135 x$, where y is gas side mol fraction of the organic and x is solvent side mol fraction at equilibrium. Assume tray efficiency of 80%. **18**
6. Nicotine in water is to be recovered using pure kerosene as solvent. Distribution law for nicotine in water and kerosene at equilibrium is given by : $y = 0.97 x$ where y is kg nicotine/kg kerosene and x is kg nicotine/kg water. Water and kerosene are not miscible with each other. The scheme of extraction is to contact 100 kg of the aqueous solution containing 3 wt% nicotine with 60 kg kerosene in first stage and with another 60 kg kerosene in the second stage. Calculate % recovery of nicotine from the feed solution at the end of the second stage. **16**
7. With reference to absorption as a unit operation write the following notes : **16**
- a) Adsorption equilibrium
 - b) Selection guidelines for adsorbent
 - c) Temperature Swing Adsorption
 - d) Industrial Use.
8. Component X in water is to be recovered using pure Y as solvent. Distribution law for X in water and Y at equilibrium is given by : $y = 0.9 x$ where y is kg X/kg Y and x is kg X/kg water. Water and Y are not miscible with each other. Compare recovery of X using three stages with the recovery obtained using single stage option. The ratio of total Y to feed water remains the same at 1:1 in both the cases. In three stage option, solvent can be assumed to be evenly distributed over the stages. Solve graphically. **16**
-



Seat No.	
----------	--

T.E. (Petrochemical) (Semester – II) Examination, 2014
REACTION ENGINEERING – I
(2008 Course)

Time : 3 Hours

Max. Marks : 100

- Instructions :**
- 1) Answer **any three** questions **each** from remaining questions from Section I and Section II.
 - 2) Answers to the **two** Sections should be written in **separate** answer books.
 - 3) **Neat** diagrams must be drawn and well commented.
 - 4) Use of logarithmic tables and electronic pocket Calculator is **allowed**.
 - 5) Figures to the **right** indicate **full** marks.
 - 6) Assume suitable data, **if necessary**.

SECTION – I

1. Attempt **any three** from the following. **18**
- i) Explain the effect of temperature on reaction rate according following theories :
 - a) Arrhenius Theory
 - b) Collision Theory
 - c) Transition State Theory
 - ii) Determine the order of the reaction and the reaction rate constant for the thermal decomposition of nitrous oxide at 1025 K using following data :

T(K)	590	600	620	650	655
k(cm ³ /gmol.sec)	520	755	1700	4020	5030
 - iii) Derive an expression for a second order irreversible reaction taking place in an isothermal variable volume batch reactor.
 - iv) Using the integral method of analysis, obtain a relationship for determining 'k' for a first order irreversible reaction.
 - v) In a homogeneous isothermal liquid polymerization, 20% of the monomer disappears in 34 minutes for initial monomer concentration of 0.04 and also for 0.8 mole/liter. What rate equation represents the disappearance of the monomer ?

OR

P.T.O.



2. Determine the reaction order and the rate constant for a single reaction of the type $A \rightarrow \text{products}$ based on the following experimental information obtained at isothermal conditions at $V = \text{const}$

t (min)	0	5	10	15	20	25	30	35	40	∞
$C_A \left(\frac{\text{mol}}{\text{lit}} \right)$	1	0.58	0.41	0.32	0.25	0.22	0.19	0.16	0.14	≈ 0

The last data point simply indicates that after a very long time (several hours as compared to minutes) practically no. A is found. Thus, at the experimental conditions used the reaction is practically irreversible.

Note : You may use any method, i.e. Differential or Integral method to solve this problem.

18

3. a) Consider gas phase reaction $2A \rightarrow B + 2C$, for which the rate equation is given by: $r_A = -kC_A^2$. Conversion of A is expected to be 90%. Determine the time required to carry out the above reaction in an ideal batch reactor operated at constant temperature and constant pressure. 8
- b) The first order homogeneous gaseous reaction $A \rightarrow 3.5R$ is carried out in an isothermal batch reactor at 2 atm pressure with 20 mole % inerts present, and the volume increases by 50% in 20 min. In case of constant volume reactor, determine the time required for the pressure to reach 8 atm if the initial pressure is 5 atm, 2 atm of which consists of inerts. 8

OR

4. a) The following elementary, liquid-phase reactions are taking place in a batch reactor operated under isothermal conditions: $A \xrightarrow{k_1} B \xrightarrow{k_2} C$ and $A \xrightarrow{k_2} P$. Find the final concentrations of A and B in terms of k_1 , k_2 , C_{AO} (the initial concentration of A) and t (time). The reactor contains no. B, C or P initially. 8
- b) Find the first-order rate constant for the disappearance of A in the gas reaction $A \rightarrow 1.75B$ if the volume of the reaction mixture, starting with pure A increases by 60% in 6 min. The total pressure within the system stays constant at 1.4 atm, and the temperature is 25°C. 8
5. a) For a first order gas reaction with stoichiometry $A \rightarrow B$, we calculate the size of plug flow reactor for a given duty (99% conversion of pure A feed) to be $V = 39$ liters. The reaction stoichiometry is corrected as $A \rightarrow 3B$. With this corrected stoichiometry, determine required volume of plug flow reactor. 10
- b) Differentiate constant volume and variable volume methods of analysis of reactors. 6

OR



6. Consider the elementary, liquid-phase reactions, $A \xrightarrow{k_1} B \xrightarrow{k_2} C$ and $A \xrightarrow{k_3} P$ taking place in an ideal CSTR operated at steady state conditions.
- Determine the concentrations of A, B, C and P in the exit stream in terms of k_1, k_2, k_3 , space time of the reactor, and concentration of A in the feed stream (C_{AO}). Assume feed stream does not contain B, C or P.
 - Under the condition $k_1 = k_2 = k_3 = k$, show that the space time of the CSTR required to maximize the concentration of B in the exit stream is $1/\sqrt{2k}$.
 - At the space time mentioned in part (b), determine the concentrations of A,B,C and P in the exit stream.

16

SECTION – II

7. Between 0°C and 100°C determine the equilibrium conversion for the elementary aqueous reaction

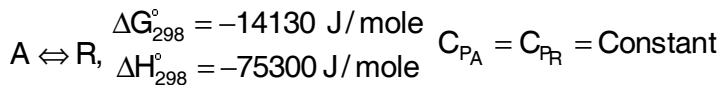

- Present the results in the form of a plot of temperature versus conversion.
- What restrictions should be placed on the reactor operating isothermally if we are to obtain a conversion of 75% or higher ?

18

OR

- What is a Recycle reactor ? Define Recycle ratio and give its significance.
 - Explain the best operating conditions for parallel reactions.
 - How does the concentration level of reactants affect the product distribution in parallel reactions ? Explain with suitable examples.
9. Substance A in the liquid phase produces R and S by the following reactions :

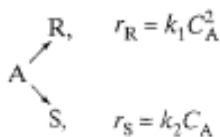

The feed ($C_{AO} = 1.0, C_{RO} = 0, C_{SO} = 0.3$) enters two mixed flow reactors in series ($\tau_1 = 5 \text{ min}, \tau_2 = 15 \text{ min.}$).

Knowing the composition in the first reactor ($C_{A1} = 0.45, C_{R1} = 0.25, C_{S1} = 0.0.65$), find the composition leaving the second reactor;.

16

OR



10. The tracer output concentration and time data are given below in Table 1 represent a continuous response to a pulse input into a closed vessel which is to be used as a chemical reactor. Calculate the mean residence time of fluid in the vessel t , and tabulate and plot the exit age distribution E .

(Table 1. Time verses Tracer output concentration)

Time t , min	Tracer Output Concentration, C_{pulse} , gm/liter fluid
0	0
5	3
10	5
15	5
20	4
25	2
30	1
35	0

16

11. The decomposition of A, given by $A_{(g)} \xrightarrow{k} B_{(g)} + 6C_{(g)}$, is first order with respect to A, with a rate constant of $k = 0.0155 \text{ s}^{-1}$ at a temperature of 953 K. If the decomposition occurs in a constant volume batch reactor at 953 K, calculate the following for 40% conversion of A :
- Time taken to reach 40% conversion of A.
 - Mole fraction of C in the reaction mixture when 40% conversion of A is reached.
 - Percentage increase of pressure within the reactor.

16

OR

12. Write short notes :
- Product distribution and Temperature in Multiple Reactions
 - Causes of Nonideal Flow
 - Optimum Temperature Progression.

16



Seat No.	
-----------------	--

**T.E. (Polymer Engg.) (Semester – II) Examination, 2014
MATHEMATICAL METHODS FOR POLYMER ENGINEERING
(2008 Pattern)**

Time : 3 Hours

Max. Marks : 100

- Instructions :**
- i) Answer Q. 1 or Q. 2, Q. 3 or Q. 4, Q. 5 or Q. 6. from Section I and Q. 7 or Q. 8, Q. 9 or Q. 10, Q. 11 or Q. 12 from Section II.
 - ii) Answers to the **two** Sections should be written in separate answer-books.
 - iii) Black figures to the **right** indicate **full** marks.
 - iv) Neat diagrams must be drawn **wherever** necessary.
 - v) Use of electronics pocket calculator is **allowed**.
 - vi) Assume suitable data if **necessary**.

SECTION – I

1. a) Prove that $\mu\delta = \frac{\Delta}{2} + \frac{\Delta E^{-1}}{2}$ with usual notations. 3
- b) Given the values below, evaluate $f(9.5)$ given $f(7) = 3$, $f(8) = 1$, $f(9) = 1$ and $f(10) = 9$ using Lagrange's formula. 7
- c) Evaluate $\int_1^2 e^{-x/2} .dx$ using Simpson's $\frac{1}{3}$ rule and using four intervals. 7

OR

2. a) Evaluate $\int_0^3 \frac{dx}{1+x}$ with 7 ordinates by using Simpson's $\frac{3}{8}$ rule and hence evaluate $\log 2$. 5
- b) Find $f'(1.1)$ and $f''(1.1)$ from the following table. 6

t	1.0	1.2	1.4	1.6	1.8	2.0
f(t)	0.0	0.1280	0.554	1.296	2.432	4.0

- c) Calculate the value of $\tan 48^\circ 15'$ from the following table. 6

x°	45	46	47	48	49	50
tan x°	1.00	1.03053	1.07237	1.11061	1.15037	1.19175



3. a) Solve $x^3 - 5x + 3 = 0$ by Regula – Falsi method. 6
 b) Solve by Jacobi iteration method the system,
 $8x - 3y + 2z = 20$
 $6x + 3y + 12z = 35$
 $4x + 11y - z = 33$ 5
 c) Using the method of least square, fit a straight line to the following data. 6

x	1	2	3	4	5
y	2	4	6	8	10

OR

4. a) Fit a second degree parabola to the following data using method of least squares. 5

x	0	1	2	3	4
y	1	1.8	1.3	2.5	6.3

- b) Solve by Gausse-Seidal method, the following system of equations.
 $28x + 4y - z = 32$
 $x + 3y + 10z = 24$ and
 $2x + 17y + 4z = 35$ 6
 c) Find a positive real root of $x - \cos x = 0$ by bisection method till four iterations lying between 0 and 1. 6
 5. a) Use Runge-Kutta method of fourth order to solve the following differential equation, in the interval $[0, 0.4]$ and $h = 0.2$
 and $\frac{dy}{dx} = \frac{y+x}{y-x}$ $y(0) = 1$. 8

- b) Solve $\frac{\partial^2 u}{\partial x^2} + \frac{\partial^2 u}{\partial y^2} = 0$ in the following square region with boundary condition as shown in figure. 8

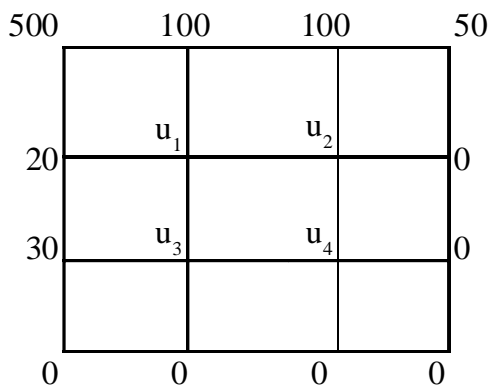

OR



6. a) Solve $\frac{dy}{dx} = y - \frac{2x}{y}$, $y(0) = 1$, in the range $0 \leq x \leq 0.2$ using modified Euler method.
 (h = 0.1). 8
- b) Solve the partial differential equation over the square with sides $x = 0, y = 0; x = 3$ and $y = 3$ with $u = 0$ on the boundary of mesh length 1 and $\frac{\partial^2 u}{\partial x^2} + \frac{\partial^2 u}{\partial y^2} = -15(x^2 + y^2 + 5)$. 8

SECTION – II

7. a) Solve the following LPP by using simplex method
 Maximize $z = 3x_1 + 6x_2 + 2x_3$
 Subject to $3x_1 + 4x_2 + x_3 \leq 2$
 $x_1 + 3x_2 + 2x_3 \leq 1$
 and $x_1, x_2, x_3 \geq 0$ 10
- b) Write the dual of the following LP problem
 Maximize $z = 2x_1 + 3x_2$
 Subject to $x_1 - 2x_2 \leq 4, 4x_1 - x_2 \leq 10$
 $2x_1 + 3x_2 \leq 18, x_1 - x_2 \leq 4$
 and $x_1, x_2 \geq 0$ 6

OR

8. a) Solve the following LPP by using simplex technique
 Minimize $z = x_1 - 3x_2 + 2x_3$
 Subject to $3x_1 - x_2 + 3x_3 \leq 7$
 $-2x_1 + 4x_2 \leq 12$
 $-4x_1 + 3x_2 + 8x_3 \leq 10$
 and $x_1, x_2, x_3 \geq 0$ 10
- b) Write the dual of following LPP
 Maximize $z = 3x_1 + 5x_2 + 4x_3$
 Subject to $2x_1 + 3x_2 \leq 8$
 $2x_2 + 5x_3 \leq 10$
 $3x_1 + 2x_2 + 4x_3 \leq 15$
 and $x_1, x_2, x_3 \geq 0$ 6

9. a) For the following distribution, find
 i) First four moments about the mean and β_1, β_2

x	2	2.5	3	3.5	4	4.5	5
f	5	38	65	92	70	40	10

6



b) Compute the coefficient of correlation for the following data

$n = 25, \sum x = 75, \sum y = 100, \sum x^2 = 250, \sum y^2 = 500, \sum xy = 325$ 5

c) A manufacturer of cotter pins knows that 2% of his product is defective. If he sells catterpins in boxes of 100 pins and guarantees that not more than 5 pins will be defective in a box, using Poisson distribution, find the probability that a box will fail to meet the guaranteed quality. 6

OR

10. a) If a coin is tossed 10 times, find the probability that
 i) at least 6 heads will appear
 ii) exactly 5 heads will appear. 6

b) In a certain examination test 1000 students appeared in a subject of Mathematics. Average marks obtained were 50% with standard deviation 5%. How many students are expected to obtain more than 60% marks, if marks are distributed normally ? [$z = 2, A = 0.4772$]. 5

c) Regression line of y on x is $8x - 10y + 66 = 0$
 and Regression line of x on y is $40x - 18y = 214$
 Find \bar{x}, \bar{y} , correlation coefficient between x and y and the standard deviation of y. 6

11. a) If covariant components of a tensor are $xy, 2y - z^2, xz$ in Cartesian system. Find its covariant components in cylindrical system. 6
 b) Show that dx^k is a contravariant tensor of rank one. 5
 c) Find g^{jk} corresponding to $ds^2 = 5(dx^1)^2 + 3(dx^2)^2 + 4(dx^3)^2 - 6dx^1dx^2 + 4dx^2dx^3$. 6

OR

12. a) If A_r^{pq} and B_r^{pq} are tensors, prove that their sum and difference are tensors. 5

b) If covariant components of a tensor are xy, y^2 in rectangular system, find their covariant components in polar system. 6

c) Show that
 i) $[pq, r] = g_{rs} \left\{ \begin{matrix} s \\ pq \end{matrix} \right\}$
 ii) $\frac{\partial g_{pq}}{\partial x^m} = [pm, q] + [qm, p]$. 6



[4658] – 148

Seat No.	
-------------	--

T.E. (Polymer Engineering) (Semester – II) Examination, 2014
INSTRUMENTATION AND PROCESS CONTROL
(2008 Course)

Time : 3 Hours

Max. Marks : 100

- Instructions :**
- 1) Answers to the **two** Sections should be written in **separate** books.
 - 2) Draw **neat** diagrams **wherever** necessary.
 - 3) Numbers to the **right** indicate **full** marks.
 - 4) Assume suitable data, if **necessary**.
 - 5) **Use** of logarithmic table, electronic pocket calculators is **allowed**.

SECTION – I

1. a) Explain the various Static and Dynamic characteristics of measuring instruments. 12
- b) Explain the role of Calibration in instrumentation. What do you understand by the term Calibration ? 6

OR

2. a) A pressure gauge instrument is specified as having range of 100 – 500 bar and an accuracy of ± 0.5 bar and sensitivity of 0.3 divisions/bar and resolution of 0.1% full scale deflection. Find range, sensitivity and accuracy. 6
- b) Write short note on : 12
 - i) Classification of instruments
 - ii) Transducer
3. a) Explain different principles, effects and laws on which thermoelectric temperature measurements depend. 10
- b) Write short note on Strain Gauge. 6

OR

4. a) List various temperature measuring instruments and describe any one in detail. 10
- b) What are elastic element traducers to measure pressure and explain any one in detail. 6
5. Differentiate between differential pressure flow meters Vs variable area flow meters. Explain in detail capacitance liquid level indicator system. 16

OR

6. a) Draw the diagram and explain construction, working, advantages and disadvantages of orifice meter. 8
- b) Explain the importance of viscosity measurement in polymer industry and suggest suitable instruments for doing so. 8

P.T.O.



SECTION – II

7. a) Explain the term process control and discuss any three benefits that can be achieved via process control system. **10**
- b) Explain the following terms : **8**
- i) set point
 - ii) error
 - iii) time constant
 - iv) dead time
 - v) load.

OR

8. a) Explain the following terms with **one** example : **8**
Input variable, Output variable, Manipulated variable, Disturbances.
- b) A thermometer (first order system) with time constant of 15 sec is placed in temperature bath and after it reaches steady state of 60°C, it is placed into hot fluid which is at 80°C. Find out the response of thermometer. **10**
9. a) Explain with standard block diagram open loop transfer function and closed loop transfer function. **8**
- b) Write a note on servo and regulator problem control system. **8**

OR

10. a) Explain with neat diagram the negative feedback control system with one example and compare with the positive feedback system. **8**
- b) Write a note on controller tuning. **8**
11. a) Discuss with neat diagram the mode of Proportional (P) control action. **8**
- b) Discuss the importance of advanced process control. **8**

OR

12. Write a note on : **16**
- i) Digital control system
 - ii) Programmable logic control.



Seat No.	
-------------	--

**T.E. (Computer) (Semester – II) Examination, 2014
PRINCIPLES OF PROGRAMMING LANGUAGES
(2008 Course)**

Time : 3 Hours

Max. Marks : 100

- Instructions :** 1) Answer **any 3** questions from **each** Section.
2) Answers to the **two** Sections should be written in **separate** books.
3) **Neat** diagrams must be drawn **wherever** necessary.
4) **Black** figures to the **right** indicate **full** marks.
5) Assume suitable data, if **necessary**.

SECTION – I

1. a) Explain in detail following characteristics of a good programming language
1) Orthogonality 2) Uniformity 3) Implementability
4) Readability 5) Writability. 10
b) Explain with suitable example implicit and explicit type conversions. 8

OR
2. a) Explain programming language paradigm in detail. 8
b) What do you mean by Bottom up and Top-down programming approach ? Explain with help of example. 8
c) Explain term binding in short. 2
3. a) What are the benefits and limitations of procedural programming language. 8
b) Explain the basic elements of PASCAL programming language. 8

OR
4. a) What is the use of local and global variables ? Explain with example. 4
b) Compare C with PASCAL programming language. 6
c) Explain with example the concept of referencing environment. 6
5. a) Define Java Package. How to create user defined package ? Explain with suitable code how to implement package with its compilation and execution. 8
b) Compare different features of C++ with Java. 8

OR
6. a) Compare abstract base class and interface in Java. 4
b) Explain Multithreading concept with respect to Java. 8
c) Explain the use of 'instance of' operator. 4

P.T.O.



SECTION – II

7. a) What is a need of a framework ? Draw and explain in brief various components of .NET framework. 8
- b) What is event handler ? How it is designed ? 6
- c) Compare C# with Java. 4

OR

8. a) Explain following object oriented concepts of .NET class object with suitable example 8
- 1) Finalizers
 - 2) IDisposable
 - 3) Delegates
 - 4) Events.
- b) Describe the following significant features supported by C# language. 8
- 1) Strong data typing
 - 2) Name space.
- c) What is assembly and delegates in C# ? 2
9. a) Explain how backtracking works in Prolog. 8
- b) Explain resolution and unification in logic programming with suitable example. 8

OR

10. a) Consider following prolog database of cities and respective states. 8
- Location (Ahmedabad, Gujrath)
- Location (Pune, Maharashtra)
- Location (Nagpur, Maharashtra)
- Location (Mysore, Karnataka)
- Answer the following queries based on above data base.
- 1) Specify goal to list all states
 - 2) Specify goal to find the state of Mysore city.
- b) Explain following conditional predicates with Prolog. 8
- i) CUT
 - ii) If then else.
11. a) Consider List L = (A, B, C). Write the output of following 4
- i) (caar L)
 - ii) (cddr L)
 - iii) (car(cdr(cdrL))).
- b) State various LISP data types. 4



- c) Compare functional and imperative language with respect to following issues 8
- 1) Syntactic structure
 - 2) Semantics
 - 3) Concurrent execution
 - 4) Data structure.

OR

12. a) Write a LISP function to concatenate two lists. 6
- b) Consider 4
- X = (a, b, c, d, e)
- Y = Reverse of X. Write output of
- i) (caddr X)
 - ii) (nth 2(cdr X))
 - iii) (append Y X)
 - iv) (length(append X(nth 2 (cdr X))))
- c) Explain numeric predicate function in LISP. 6
-



[4658] – 157

Seat No.	
----------	--

T.E. (Computer) (Semester – II) Examination, 2014
COMPUTER NETWORKS
(2008 Pattern)

Time : 3 Hours

Max. Marks : 100

- Instructions :**
- 1) Answer **any 3** questions from **each** Section.
 - 2) Answer to the **two** Sections should be written in **separate** books.
 - 3) **Neat** diagrams must be drawn **wherever** necessary.
 - 4) **Black** figures to the **right** indicate **full** marks.
 - 5) **Use** of logarithmic tables slide rule, Mollier charts, electronic pocket calculator and steam tables is **allowed**.
 - 6) Assume suitable data, if **necessary**.

SECTION – I

1. a) What are the two types of transport services that the Internet provides to its applications ?
What are some characteristics of each of these services ? 6
- b) It has been said that flow control and congestion control are equivalent. Is this true for the Internet's connection oriented service ? Are the objectives of flow control and congestion control same. 6
- c) Explain different application layer architectures. 4
- OR
2. a) What is the difference between persistent HTTP with pipelining and persistent HTTP without pipelining ? Which of the two is used by HTTP/1.1 ? 5
- b) When web pages are sent out, they are prefixed by MIME headers. Why ? 5
- c) List and explain services provided by DNS. 6
3. a) Write a pseudo-code for client and server to setup a connection-oriented service between them. 8
- b) Explain TCP header in short. 4
- c) Explain TCP connection release process. 4
- OR
4. a) What are the approaches toward congestion control ? 8
- b) How TCP, a connection-oriented reliable protocol provides reliable service on top of IP, a connectionless unreliable protocol ? 8
5. a) What is class based QoS ? Explain. 8
- b) List and explain the techniques for achieving good QoS. 10

OR

P.T.O.



6. a) How TCP estimates RTT and timeout ? 6
 b) Consider sending a packet from a sending host to a receiving host over a fixed route. List the delay components in the end-to-end delay. Which of these delays are constant and which are variable ? 6
 c) Explain the methods to resolve DNS query. 6

SECTION – II

7. a) Compare link state and distance vector routing algorithms. 4
 b) Explain distance vector routing algorithm with example. What is count to infinity problem ? 8
 c) What are components of a router ? What is the difference between routing and forwarding ? 4

OR

8. a) Compare and contrast the IPv4 and IPv6 header fields. Do they have any fields in common ? 8
 b) Consider sending a 3000 byte datagram into a link that has an MTU of 500 bytes. Suppose the original datagram is stamped with identification number 422. How many fragments are generated ? What are their characteristics ? 8
 9. a) Give taxonomy of routing protocol. 4
 b) What is jumbogram ? What is the maximum size of jumbogram ? Explain the extension header for this option. 4
 c) Suppose an ISP owns the block of addresses of the form 101.101.128.0/17. Suppose it wants to create four subnets of this block with each block having the same number of IP addresses. What are the prefixes for the four subnets ? What are the starting and last addresses for each of the subnet ? What are the broadcast addresses for each subnet ? 8

OR

10. a) What is multicasting ? Explain multicasting routing algorithm. 8
 b) Suppose an application generates chunks of 40 bytes of data every 20 m sec. and each chunk gets encapsulated in a TCP segment and then an IP datagram. What percentage of each datagram will be overhead, and what percentage will be application data ? 6
 c) Why are different inter-As and intra-As routing protocols used in the Internet ? 2
 11. a) Write short note on PPP ? 6
 b) List and explain internetworking devices. 6
 c) What are some of the possible services that a link layer protocol can offer to the n/w layer ? Which of these link layer services have corresponding services in IP ? In TCP ? 6

OR

12. Write short note on : 18
 a) ATM
 b) MPLS
 c) HDLC.



Seat No.	
----------	--

**T.E. (Information Technology) (Semester – II) Examination, 2014
SYSTEM SOFTWARE PROGRAMMING
(2008 Course)**

Time : 3 Hours

Max. Marks : 100

- Instructions :** 1) Answer Q.1 or Q.2, Q.3 or Q.4, Q.5 or Q.6 from Section I and Q.7 or Q.8, Q.9 or Q.10, Q.11 or Q.12 from Section II.
2) Answers to the **two** sections should be written in separate answer books.
3) **Neat** diagrams must be **drawn** wherever necessary.
4) Figures to the **right** side indicate **full** marks.
5) Assume suitable data if **necessary**.

SECTION – I

1. a) What activities are conducted during Analysis and Synthesis phase of a two pass assembler. **8**
b) Explain the Back-patching with suitable example. **6**
c) Explain the term system programming. **2**

OR

2. a) What do you mean by assembler directives ? Explain how assembler directives LTORG, ORIGIN are processed in first pass with example. **8**
b) Distinguish between Variant I and Variant II representations used for Intermediate code of two pass assembler. **8**
3. a) Define the term macro. Explain the terms lexical expansion and semantic expansion with respect to macro. **10**
b) Explain with example following macro facilities. **8**
i) Expansion time loops
ii) Change of flow during macro expansion.

OR

4. a) **MACRO** **12**
ABC &X, &N, ® = AREG
LCL &M
&M SET 0
MOVER ®, =0'
.MORE MOVEM ®, &X + &M
&M SET &M + 1
AIF (&M NE N) .MORE



```

MEND
START 500
MOVER CREG, B
ABC AREA ,10
ADD CREG ,= '1'
END

```

- i) Show the contents of different tables with output after processing of macro definition.
ii) Show the expanded assembly language program.
- b) Explain the actual arguments and dummy arguments with examples. **6**
5. a) Draw and explain the block diagram of phases of compiler. **8**
b) Differentiate between Compiler and Interpreter. **2**
c) What are the advantages and disadvantages of top down parsing. **6**

OR

6. a) Consider following program. **10**

```

void main()
{
    int p,q,r;
    P = 10;
    P = P + 5;
    printf ("10");
}

```

Write down the output of lexical analyzer and also show the contents of different tables.

- b) Explain the role of grammar in Compilers. Give types of grammar and explain the example of Context free grammar. **6**

SECTION – II

7. a) Explain any two issues in code generation. **8**
b) Explain any two intermediate code formats with examples. **8**

OR

8. a) Show the triple and quadruple representation of following three address statements. **8**

```

t1 := - c
t2 := b * t1
t3 := - c
t4 := b * t3
t5 := t2 + t4
a := t5

```

- b) Explain any two machine independent code optimization techniques with example. **8**



- 9. a) Compare absolute loading scheme VS Compile and Go loading scheme. **6**
- b) Explain RLD and TXT cards. **4**
- c) Explain various databases required for Pass I and Pass II of direct linking loader. **8**

OR

- 10. a) Compare linking loader and linkage editor. **4**
- b) Explain following.
 - i) Relocating loaders **6**
 - ii) Overlay Structure **6**
- c) Explain BSS loading scheme with the help of an example. Explain how four basic functions of loader are performed in BSS loading scheme. **8**
- 11. a) Explain Programming Environment in detail. **6**
- b) What are various types of Editors ? With the help of block diagram explain typical Editor structure. **10**

OR

- 12. a) Explain the significance of LEX with example. **8**
- b) Write short notes on
 - i) User Interfaces **8**
 - ii) YACC. **8**



Seat No.	
----------	--

**T.E. (IT) (Semester – II) Examination, 2014
PROGRAMMING PARADIGMS
(2008 Pattern)**

Time : 3 Hours

Max. Marks : 100

- Instructions :** 1) Answers to the **two** sections should be written in **separate** answer books.
2) Answer **any three** questions from **each** Section.
3) Neat diagrams must be drawn **wherever** necessary.
4) Figures to the **right** side indicate full marks.
5) Use of calculator is **allowed**.
6) Assume suitable data if necessary.

SECTION – I

1. a) What is data object ? What is life time of data object ? Explain programmer and system defined data object. 10
b) What is type checking ? What is static and dynamic type checking ? Explain the concepts of type conversions and coercions ? 8
- OR
2. a) State and explain the importance of learning programming languages. 10
b) What is binding and binding names ? What are the different binding times ? 8
3. a) Explain with example the content of code segment and Activation record at run time. 8
b) Compare the programming language 'C' and PASCAL with respect to 8
 - 1) Subprogram declaration
 - 2) Subprogram invocation
 - 3) Variable declaration
 - 4) Control loops
- OR
4. a) What do you mean by activation records ? How this feature is used for implementing recursive function calls ? 8
b) What do you mean by exception ? Explain its use with example. 8
5. a) What is AWT ? Explain Applet life cycle. 8
b) Explain following variables supported by Java with example. 8
 - i) Instance variable ii) Static variable
 - iii) Local variable iv) Parameter variable

OR



6. a) Explain the concept of inheritance. What are different types of inheritance supported in C++ and Java ? 8
- b) Explain the following concept in Java. 8
- i) Panel ii) Frame iii) Canvas iv) Container

SECTION – II

7. a) Consider the following PROLOG database of cities and respective states 10
- Location (Banglore, Karnataka)
Location (Mumbai, Maharashtra)
Location (Pune, Maharashtra)
Location (Surat, Gujrat)
Location (Hyderabad, AP)
- Answer the following queries
- a) Specify GOAL to list all cities
b) Specify GOAL to find the state of Pune city.
- b) What is declarative programming paradigm ? How it is different than imperative paradigm ? 8

OR

8. a) Write a short note on Lambda calculus. 5
- b) Write the mathematical properties of functional programming language. 5
- c) What is Unification and Resolution ? Why these are important in Logic programming ? 8
9. a) What are the design issues for language support for concurrency ? 8
- b) What is meant by parallel programming ? What are the design principles for parallel programming. 8

OR

10. a) State the different Synchronization mechanisms of parallel programming language. Explain any two. 8
- b) Enlist and explain the eight socket primitives required for network connection. 8
11. a) What are the design principles of windows programming ? 8
- b) Explain design principles data flow programming and note firing schemes used in data flow computation. 8

OR

12. a) Explain various types of data types and data structures supported by LISP. 8
- b) How we can handle synchronization mechanism in parallel programming ? 6
- c) What is the concept of node in Data Flow Programming ? 2



Seat No.	
-------------	--

**T.E. (Information Technology) (Semester – II) Examination, 2014
HUMAN COMPUTER INTERACTION AND USABILITY
(2008 Pattern)**

Time : 3 Hours

Max. Marks : 100

- Instructions :** 1) Answer Question 1 or 2, 3 or 4, 5 or 6 from Section – I and Question 7 or 8, 9 or 10 and 11 or 12 from Section – II.
 2) Answers to the **two** Sections should be written in **separate** books.
 3) **Neat** diagrams must be drawn **wherever** necessary.
 4) Figures to the **right** indicate **full** marks.
 5) **Assume** suitable data, **if necessary**.

SECTION – I

1. a) Suggest ideas for an interface, which uses the properties of sound effectively. 6
- b) How does making a phone call differ when using :
 – Public phone box
 – A Cell Phone ?
- How have these devices been designed to take into account
- a) The kind of users
 b) Types of activity being supported
 c) Context of use ? 6
- c) What is ergonomics ? Explain its significance in interface design. 6

OR

2. a) Consider following six layouts for cursor keys

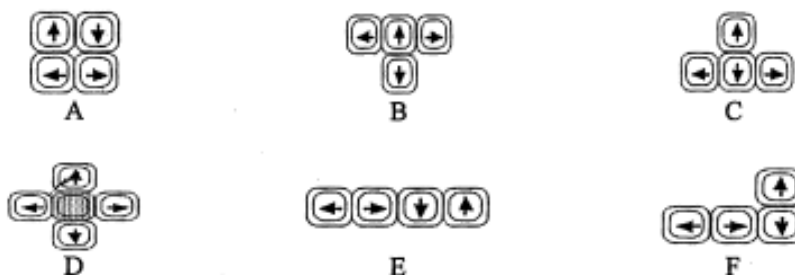

- Comment on each of these layouts. Which one do you think is more suitable ? Also explain why it is more suitable ? 8
- b) Compare STM and LTM of human with respect to capacity, access time and forgetting. 6
- c) Explain Inductive reasoning and Abductive reasoning with example. 4

P.T.O.



3. a) What are the different life cycle models in HCI ? Explain the any one lifecycle model in detail. **8**
- b) Explain following WIMP interface elements with respect to any text editor.
- Icons
 - Menus
 - Toolbars
 - Dialog boxes. **8**

OR

4. a) List different interaction styles. Explain command line interface and menus with advantages and disadvantages. **8**
- b) Explain interaction design process. **8**
5. a) Explain “Eight golden rules of interface design”. **8**
- b) Explain
- Scenarios
 - Expert reviews. **8**

OR

6. a) What is the distinction between a process-oriented and a structure oriented design rationale technique ? Would you classify psychological design rationale as process or structure oriented ? Why ? **6**
- b) With respect to Human Diversity how to accommodate users with disabilities and elderly users. **6**
- c) Consider two different ATM machines. One giving away the cash and then ejecting the bank card and the other ejecting the bank card first and then dispensing the cash. Which is a better interface from interaction design point of view ? Justify. **4**



SECTION – II

7. a) Explain Hutch World case study evaluation framework. 12
b) Explain any two evaluation paradigms for UI design. 4
OR
8. a) Explain DECIDE evaluation framework. 10
b) What usability standards are necessary in designing home page for e-governance websites ? 6
9. a) Explain different dialog design notations. 8
b) Explain GOMS model by taking appropriate task. Also discuss the issue of closure in terms of your GOMS description. 8
OR
10. a) Produce a high-level Hierarchical Task Analysis (HTA) showing how you would find information on a website. Assume the site has a search facility as well as normal links. 8
b) Explain status event analysis with example. 8
11. a) Consider following two shared application-
– Shared PCs and shared window systems
– Shared editors.
What are the main issues that need to be addressed in the design of these applications ? 8
b) Explain centralized and replicated architectures of groupware, identify the strengths and limitations of each. 6
c) What is CSCW ? Explain how it is applicable to education. 4
OR
12. Write a short note (**any three**) : 18
1) Information and data visualization
2) Augmented reality
3) Any three devices for virtual reality
4) Ubiquitous computing.
-



[4658] – 17

Seat No.	
-------------	--

**T.E. (Mechanical) (Semester – II) Examination, 2014
TURBOMACHINES
(2008 Course)**

Time : 3 Hours

Max. Marks : 100

- Instructions :** 1) Answer **any 3** questions from each Section.
2) Answers to the **two** Sections should be written in separate books.
3) **Neat** diagrams must be drawn **wherever** necessary.
4) **Black** figures to the **right** indicate full marks.
5) **Use** of logarithmic tables slide rule, Mollier charts, electronic pocket calculator and steam tables is **allowed**.
6) Assume suitable data, if **necessary**.

SECTION – I

UNIT – I

1. a) A 2-D horizontal water jet impinges on a moving flat vane which is inclined to the vertical at an angle of 30 degrees. The jet flow rate is 10 kg/s and the jet velocity is 20 m/s. The vane moves at 30 m/s in the direction exactly opposite to the jet. Determine the normal force (Perpendicular to the vane itself) exerted by the jet on the vane assuming the flow to be inviscid. Derive the formula that you use. Draw velocity triangles at the inlet and outlet. **8**
- b) Describe with a neat sketch all the important details of a Pelton wheel installation. Describe the use of penstock, surge tank, nozzle, spear, deflector, casing and brake nozzle. What is the typical range of head and specific speed for a Pelton wheel ? How can one improve the specific speed of a Pelton turbine ? **8**

OR

2. a) A Pelton wheel runner works under a net head of 300 meters of water and produces 2 MW of hydraulic power at 500 rpm. What is the diameter of the jet if the velocity coefficient of the nozzle is 0.96 ? Determine the mean pitch circle diameter of the buckets of this turbine if the speed ratio is 0.47. What is the jet ratio in that case ? Also determine the nozzle efficiency. **10**
- b) A jet enters tangentially on a single moving unsymmetrical curved vane. Derive expressions for components of the total force exerted by the jet on the vane in terms of the mass flow rate \dot{m} of the jet, overall turning angle θ of the relative flow, the jet velocity V and the vane velocity u . One component of the force is in the direction of motion of the vane and the other is across it. **6**

P.T.O.



UNIT – II

3. a) Water enters a modern Francis turbine with a flow velocity of 20 m/s. The angle of the guide vanes is 11.31 degree with respect to the tangent to the runner. Runner outer diameter is 5 m and the speed of rotation is 500 rpm. If the discharge from the turbine is axial and whirl-free and the runner develops power of 15 MW, calculate the mass flow rate of water through the turbine. Draw neat inlet and outlet velocity triangles showing necessary details. Determine the inlet blade angle and the velocity of water relative to the runner at inlet and outlet. Determine also the vane outlet angles at radii of 1 m and 2 m. **12**
- b) Describe with a neat sketch the main features of a Kaplan runner. Draw the plot of efficiency versus percentage load for Kaplan turbine and explain its connection to the constructional features of the Kaplan runner. **4**

OR

4. a) Explain the working of a draft tube in the case of hydraulic reaction turbines with the help of Bernoulli's equation. Explain clearly the recovery of head in a draft tube having constant area of cross-section. Then explain the working of a divergent draft tube. **8**
- b) A Kaplan turbine operates under a net head of 10 meters of water and generates 5 MW of hydraulic power. Turbine exit is connected to the tail race by a straight divergent draft tube having circular cross-section. Diameter of the draft tube at the entry is 3 m. If 40% of the velocity head (compared to that at the draft tube entry) is lost to the tail race, determine outlet diameter of the draft tube. If the turbine is installed 4 m above the tail race, determine the gauge pressure set up at the entry to the draft tube (i.e. exit of the runner) in meters of water column. **8**

UNIT – III

5. a) Sensors mounted on a rotor-blade of 50% - reaction steam-turbine stage measure the flow speed at rotor inlet and exit to be 142.9 m/s and 417.9 m/s respectively. The stage comprises of a stator-blade ring followed by the rotor-blade ring. The turbine is axial-flow type, well-insulated and operates at the maximum utilization factor. Static pressure and static temperature of steam at entry to the rotor are measured to be 110 bar (absolute) and 500 degree Celsius. Static pressure at the rotor exit is measured to be 100 bar (absolute) and static temperature at entry to the stage is measured to be 600 degree Celsius.

Determine

- i) Exit angles for the stator and rotor blades
 - ii) Stage specific work
 - iii) Static enthalpy changes in the rotor and the stator
 - iv) Static pressure of steam at inlet to the stage
 - v) Static temperature of steam at exit of the stage
 - vi) Static pressure changes in the rotor and the stator
 - vii) Rotational speed of the turbine.
- Mean diameter of rotor is 1.5 m. Draw neat inlet and outlet velocity triangles for the rotor blades. **14**
5. b) Explain clearly the difference between an impulse stage and a reaction stage with reference to axial-flow steam turbines. **4**

OR



6. a) What is compounding of stages in axial-flow steam turbines ? Explain velocity-compounding and pressure-compounding in the context of reaction-type steam turbines. Show clearly the variations of velocity and pressure in the axial direction. **6**
6. b) A steam turbine is being designed for the following conditions. Boiler steam is expected to enter the turbine at 150 bar (absolute) and 500 degree Celsius. To improve the power output, it is proposed to expand steam in the turbine till the static pressure drops to 10 bar (absolute). Dryness fraction of the steam leaving the turbine should be 0.8. At inlet, the mean diameter is decided to be 1.5 m with the blade height to be kept at 50 mm. Blade height at the outlet is not to exceed 200 mm. Steam enters and leaves the entire turbine axially i.e. without whirl and the velocity of flow at exit is expected to be 5% lower than that at the inlet. Determine the mean diameter of the blades at the exit and the estimated power output of the turbine if the steam mass flow rate is 2000 kg/s. Do not neglect changes in the kinetic energy of steam. **12**

SECTION – II

UNIT – IV

7. A gas-turbine power plant has technical details as follows :

Compressor inlet pressure : 1.013 bar

Compressor inlet temperature : 310 K

Compressor pressure ratio : 8

Compressor isentropic efficiency : 85%

Turbine inlet temperature : 1350 K

Turbine isentropic efficiency : 90%

Combustion chamber pressure loss : 2% of the compressor exit pressure

Turbine exit pressure = 1.013 bar

Calorific value of fuel = 40 MJ/kg

Combustion efficiency = 95%

Mechanical efficiency = 98%

Generator efficiency = 98%

Kinetic energy changes of the flow are negligible throughout. For air take $\gamma_a = 1.4$ and for products of combustion take $\gamma_g = 1.33$. Assume $R = 0.287$ kJ/kgK to be the same for both. Sketch block diagram of the plant and also show the processes on a T-s diagram. For an electrical power output of 120 MW, determine

- i) Air and fuel mass-flow rates
- ii) Gas mass-flow rate and fuel-air ratio
- iii) Thermal efficiency of the plant
- iv) Overall efficiency of the plant.

Note : While calculating mass flow rates, use compressor and turbine powers and not specific works i.e. do not make the approximation of small fuel-air ratio anywhere.

OR



8. a) Derive the expression for optimum pressure ratio for a Brayton cycle in terms of maximum and minimum cycle temperatures, compressor and turbine isentropic efficiencies. Hence show that for the optimum performance of an ideal Brayton cycle, exit temperatures for compressor and turbine must be equal. Express these temperatures in terms of the maximum and minimum cycle temperatures. **8**
8. b) With the help of neat block diagrams and T-s diagrams, explain clearly the purpose of each of following cycle improvement techniques in the context of gas-turbine power plants :
- i) Intercooling
 - ii) Exhaust-gas heat exchange
 - iii) Reheating. **8**

UNIT – V

9. a) A mono-block centrifugal pump works with a suction lift of 3 m and a delivery lift of 20 m. Suction pipe length is 3.5 m and its diameter is 60 mm. Delivery pipe length is 21 m and its diameter is 50 mm. Friction factor for both pipes is 0.02. The pump discharges 30 litres of water every second. Overall efficiency of the unit (pump + motor) is 70%. Determine the manometric head, pressure rise across the pump and electrical power consumption. **8**
9. b) Sketch neat diagram showing different heads associated with a centrifugal pump installation. Then explain the terms : suction lift, delivery lift, suction head, delivery head, manometric head, Euler head, manometric efficiency and NPSH. **8**

OR

10. a) Explain the ideal head-discharge curves (i.e. Euler head versus discharge curves) for forward-curved, straight (radial) and backward-curved vanes of the impeller of a centrifugal pump with the help of outlet velocity triangles. Assume inlet in each case to be whirl-free. Then explain why backward-curved vanes are preferred from operational-stability view point. **4**
10. b) Three pumps, differing only in the type of vanes (forward, backward and radial vanes), are being tested for their performance. Details that are common to all the three pumps are as follows :
- Impeller exit diameter = 300 mm,
 - Axial width at impeller exit = 20 mm,
 - Impeller speed = 3000 rpm,
 - Inlet whirl = zero,
 - Discharge = 50 litres per second



Vane exit angles (measured from tangent to impeller at vane exit) for forward, backward and radial types are respectively 140, 50 and 90 degrees. Draw exit triangles in all the three pumps. If head loss in the casing is 10% of the velocity head at impeller exit, determine the net head imparted to fluid in each case. If mechanical efficiency of each pump is 96% and the driving electrical motor is 98% efficient, determine the electrical power consumption and overall efficiency in each case.

12

UNIT – VI

11. a) The first stage (rotor + stator together after the inlet guide vane ring) of an axial compressor has a stagnation pressure ratio of 1.18 and an isentropic efficiency of 90%. Ambient air temperature is 25 degree Celsius and ambient air pressure is 1 bar. Determine the work input required by the stage per kg of air if $\gamma = 1.4$ and $C_p = 1.005$ kJ/kgK for air. Air enters the rotor with an absolute velocity which is inclined to the axial direction at an angle of 25 degree. The velocity of flow at rotor inlet is 150 m/s. Mean diameter of the rotor is 410.4 mm and compressor runs at 10000 rpm. Determine the inlet and exit angles of rotor blades as well as the inlet angle of stator blades. Assume 50% reaction at the mean rotor diameter. Draw neat inlet and exit velocity triangles for the rotor and determine all the velocities therein.

12

11. b) Explain slip and prewhirl in the context of centrifugal compressors.

6

OR

12. a) Air enters the impeller of a centrifugal compressor axially and leaves out in the radial direction to enter the diffuser. Impeller runs at 15000 rpm with has a stagnation pressure ratio of 4. Ambient air conditions are 25 degree Celsius and 1 bar. Impeller vanes are radial at the exit and slip effect may be neglected. Power input factor (work factor) is 1.04. If the impeller absorbs energy of 153.212 kJ to compress one kg of air, determine the isentropic efficiency of the impeller. Also determine the outer diameter of the impeller if there is no prewhirl. Take $\gamma = 1.4$ and $C_p = 1.005$ kJ/kgK for air. Draw a neat T-s diagram showing the stagnation temperatures and pressures involved in the present problem.

12

12. b) Using Buckingham's Pi theorem, derive various performance related non-dimensional parameters for compressors (neglect viscosity of fluid). Plot qualitatively the graphs of compressor pressure ratio and efficiency as function of dimensionless mass flow rate with dimensionless speed as a parameter.

6



[4658] – 176

Seat No.	
-------------	--

T.E. (Biotechnology) (Semester – II) Examination, 2014
REACTION ENGINEERING
(2008 Course)

Time : 3 Hours

Max. Marks : 100

- Instructions :** 1) Answers to the **two** Sections should be written in **separate** answer books.
2) Answer Q. 1 or 2, Q. 3 or 4, Q. 5 or 6 from Section I and Q. 7 or 8, Q. 9 or 10, Q. 11 or 12 from Section II.
3) **Neat** diagrams must be drawn **wherever** necessary.
4) Figures to the **right** side indicate **full** marks.
5) Use of calculator is **allowed**.
6) Assume suitable **data** if necessary.

SECTION – I

1. a) How temperature dependency influences activation energy ? Discuss. 6
- b) On doubling the concentration of reactant, the rate of reaction triples. Find the reaction order. 6
- c) Differentiate between Elementary and non-elementary reaction. 6

OR

2. a) Explain kinetic model for nonelementary reaction. 6
- b) Differentiate between Molecularity and order of reaction. 6
- c) Write short note with suitable example on i) Rate of Reaction ii) Order of Reaction. 6
3. a) Assuming a stoichiometry $A \rightarrow R$ for a first order reaction, the volume of plug flow reactor for 99% conversion of pure A is calculated to be 32 lit. In fact, however the reaction stoichiometry is $A \rightarrow 3R$. With this corrected stoichiometry, what is the required volume of a reactor ? 9
- b) Derive the performance equation for mixed flow reactor. 7

OR

P.T.O.



4. a) Define space time and space velocity. 3
- b) The liquid phase decomposition of reactant B is studied in mixed flow reactor and plug flow reactor. Determine the holding time required to obtain 75% conversion as initial concentration of reactant B is 0.8 mol/lit. Data given is as below : 13

C_B in Feed mol/lit	C_B in exit stream mol/lit	Holding time sec
2.00	0.65	300
2.00	0.92	240
2.00	1.0	250
1.00	0.56	110
1.00	0.37	360
0.48	0.42	24
0.48	0.28	200
0.48	0.20	500

5. a) Discuss about earliness and lateness of fluid mixing in the vessel. 4
- b) Does the degree of segregation influence conversion and product distribution in plug flow reactor ? Why ? 6
- c) Discuss in detail about tank in series model. 6

OR

6. a) A sample of tracer a dye solution at 220 K was injected as a pulse to a reactor and effective conversion measured as a function of time, resulting the following data. 10

t (min)	0	1	2	3	4	5	6	7	8	9	10	12	14
C (g/m³)	0	1	5	8	10	8	6	4	3	2.2	1.5	0.6	0

The measurement represents an exact concentration at the times listed and not average values between the various sampling tests. Construct a figure shows $E(t)$ as a function of time.

- b) Discuss about state of aggregation. 6



SECTION – II

7. a) Discuss about Ash layer controls. 12
b) What are the factors affecting on heterogeneous reactions ? 6
OR
8. a) Write note on progressive conversion model. 8
b) Write detail note on Chemical reaction controls. 10
9. a) Discuss about the mechanism of solid catalyzed reaction. 6
b) Explain : pore diffusion resistance combined with surface kinetics with example. 10
OR
10. a) Discuss about slurry reactor. 4
b) Write short note on trickle bed reactor. 6
c) Give short note on packed bed catalytic reactor. 6
11. a) Differentiate between microbial and enzyme fermentation. 8
b) Discuss about Substrate limiting microbial fermentation. 8
OR
12. A waste containing carbohydrate A decomposes in presence of enzyme E. Carbohydrate B affects the decomposition. Run were conducted and data is obtained as below. Find : i) Rate equation for the decomposition ii) The role of B in decomposition and iii) Mechanism for the decomposition. 16

$C_{A0}, \text{ mol/m}^3$	$C_A, \text{ mol/m}^3$	$C_{B0}, \text{ mol/m}^3$	$C_{E0}, \text{ mol/m}^3$	$V, \text{ cm}^3/\text{min}$
200	50	0	12.5	80
900	300	0	5	24
1200	800	0	5	48
700	33.3	33.3	33.3	24
200	80	33.3	10	80
900	500	33.3	20	120



[4658] – 177

Seat No.	
-------------	--

T.E. Biotechnology (Semester – II) Examination, 2014
FERMENTATION TECHNOLOGY – II
(2008 Course)

Time : 3 Hours

Max. Marks : 100

- Instructions :**
- 1) Answers to the **two** sections should be written in **separate** answer books.
 - 2) Answer Q. 1 or 2, Q. 3 or 4, Q. 5 or 6 from section I and Q. 7 or 8, Q. 9 or 10, Q. 11 or 12 from section II.
 - 3) **Neat** diagrams must be drawn **wherever** necessary.
 - 4) Figures to the **right** side indicate **full** marks.
 - 5) Use of Calculator is **allowed**.
 - 6) Assume suitable data if **necessary**.

SECTION – I

- 1) Write detailed notes on factors effecting fermenter design and operation. 16
OR
- 2) Give detailed notes on how aeration and agitation effect the mass transfer in Bioreactors. 16
- 3) What is the need of different unit operations for processing fermentation broths ? 16
OR
- 4) Give detailed notes on construction and working of tray dryers. List out its advantages, disadvantages and applications. 16
- 5) Explain in detail the following equipment's with neat sketch : 18
 - i) Pressure Swing Adsorption
 - ii) Temperature Swing Adsorption.OR
- 6) Derive the material balance equations for multistage crosscurrent adsorption operation with proper nomenclature and suitable assumptions. 18

SECTION – II

- 7) Define various types of leaching with suitable examples. What are the factors effecting leaching operations ? Explain in detail. 16
OR
- 8) Vegetable oil seeds containing 100 g insoluble solids and 10 g oil are contacted with 200 g of organic solvent in a single stage leaching operation. The solvent used is fresh. Determine the amount of oil left in the oil seeds after leaching. The equilibrium data can be expressed as : $N = -4y + 8$ where N is gram insoluble per gram solvent and oil and y is gram oil per gram solvent and oil.

P.T.O.



Tie line data is given as :

16

y 0.26 0.28 0.31 0.34

x 0.02 0.04 0.06 0.08

- 9) What do you mean by membrane fouling ? How does it occur ? How fouling effects mass transfer rates within the membrane ? List out the ways of recovering a fouled membrane.

16

OR

- 10) Define a membrane. What are the criteria of a good membrane ? List out the benefits of membrane separation operations compared to conventional methods.

16

- 11) Define solvent extraction. Give the difference and similarities of the two separation methods Distillation and Extraction.

18

OR

- 12) Explain the following equipment with neat sketch and list out their applications :

18

- i) Mixer settler for batch operation
- ii) Gravity settlers.



[4658] – 178

Seat No.	
-------------	--

T.E. (Bio -Technology) (Semester – II) Examination, 2014
BIOSEPARATION – I
(2008 Course)

Time : 3 Hours

Max. Marks : 100

- Instructions :** 1) Answer to the **two** sections should be written in **separate** answer books.
2) Answer **any three** questions from **each** section.
3) **Neat** diagrams must be drawn **wherever** necessary.
4) Figures to the **right** side indicate **full** marks.
5) Use of calculator is **allowed**.
6) Assume suitable data if **necessary**.

SECTION – I

1. a) Give overview of Bioseparation. What is the first step in Bioseparations for intracellular products. Describe the step with its different types. 16
- OR
2. a) Write short note on : (**any two**) 16
- 1) Ultrasonication
2) Homogenization
3) Adsorption
4) Absorption
3. a) Describe importance of column chromatography. Depict theory of chromatography in detail. 16
- OR
4. a) What is the basic difference between analytical and preparative chromatography; explain in detail with example. Write short note on scale up of chromatography ? 16
5. a) What is the membrane separation technique ? Explain the types of membranes and accordingly give examples for application of the technique to biotechnology. 18
- OR
6. a) Explain cross flow filtration with the help of following points : 10
- i) Filter Media
ii) Filter Aids
iii) Equipment
- b) Explain centrifugation and sedimentation in detail with difference in both the techniques and their application. 8

P.T.O.



SECTION – II

7. a) Explain liquid-liquid extraction in detail. Explain the solvent extraction process for antibiotics separation. 16

OR

8. Write **short** notes on : 16

- i) Crystallization
- ii) Lyophilization
- iii) Drying
- iv) A T P S

9. a) What is the scope for bioseparation techniques from research to industry explain any one example with case study ? 8

b) Explain importance of bioseparations in Biotechnology industry. 8

OR

10. Describe the synthesis of bioseparation process with the help of following points. 16

- i) Primary Recovery Stages
- ii) Intermediate Recovery Stages
- iii) Final Purification Stages

11. State the basics of following bioseparation techniques and explain the importance of the technique with the case example. **(any 2, 9 M each)** 18

- i) Cell disruption methods
- ii) Aqueous Two Phase Extraction
- iii) Chromatography
- iv) Membrane Separations.



[4658] – 18

Seat No.	
-------------	--

**T.E. (Mechanical) (Semester – II) Examination, 2014
MECHATRONICS
(2008 Course)**

Time : 3 Hours

Max. Marks : 100

- Instructions :** 1) Answer **three** questions from **each** Section.
2) Answers to the **two** Sections should be written in **separate** books.
3) **Neat** diagrams must be drawn **wherever** necessary.
4) Assume suitable data **wherever** necessary but mention **it clearly**.
5) **Use** of scientific calculator is **allowed**.

SECTION – I

1. a) Explain the three methods for level measurement. 8
- b) For a platinum resistance thermometer, the resistance coefficient of temperature is $0.004\Omega/^{\circ}\text{C}$ resistance at 40°C is 130Ω . Find the following : 8
- i) Resistance at 300°C
- ii) Temperature when resistance is 90Ω .

OR

2. a) Explain different dynamic characteristics of measurement system such as 8
- i) Response Time ii) Rise Time iii) Settling Time.
- b) A strain gauge and bridge circuits are used to measure the tension force in a bar of steel that has a cross sectional area of 10cm^2 . The strain gauge has a nominal resistance of 130Ω , and GF of 2. The bridge is supplied with 10 V. When the bar is unloaded the bridge is balanced so the output is 0 V ? Then force is applied to the bar, and the bridge voltage goes to 0.0005 V. Find the force on the bar. (Young's Modulus = $2 \times 10^5 \text{ N/mm}^2$ for steel). 8
3. a) Compare an LVDT with potentiometer as a position sensor. What are the advantages and disadvantages of using an LVDT ? 6
- b) A Potentiometer with a total range of 360° is supplied with a voltage of 9 V DC. The voltage at the wiper is 3.7 V DC. What is the present angle of the pot ? 6
- c) Describe proximity sensor with application. 4

OR

P.T.O.



4. a) Explain the working principle of optical encoders. 6
- b) The output of LVDT is connected to a 5 V voltmeter through an amplifier of amplification factor 250. The voltmeter scale has 100 divisions and the scale can be read to $1/5^{\text{th}}$ of a division and output of 2 mV appears across the terminals of the LVDT when the core is displaced through a distance of 0.5 mm. 6
- Calculate :
- i) The sensitivity of LVDT
 - ii) The sensitivity of whole set up
 - iii) The resolution of the instrument is in mm.
- c) Explain self inductance principle for displacement measurement. 4
5. a) Explain thermal system building blocks. 8
- b) Obtain the overall transfer function of the block diagram shown in figure Q.5(b) by block diagram reduction technique. 8

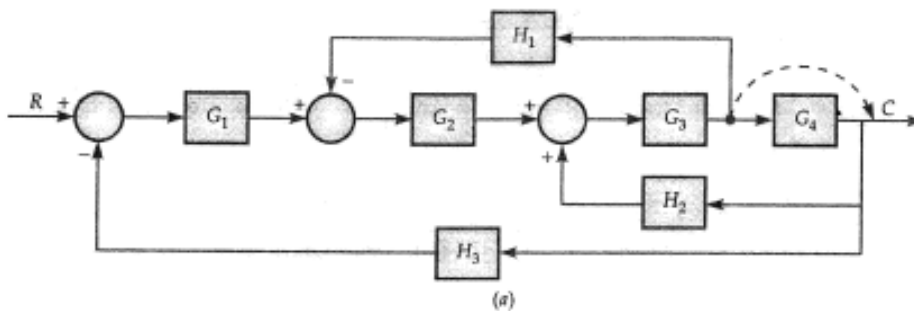

OR

6. a) Explain the detailed functioning of Data Acquisition System with the help of a detailed block diagram. 8
- b) Using block diagram reduction technique for the system shown in figure Q.6(b) find the input - output relationship. 8

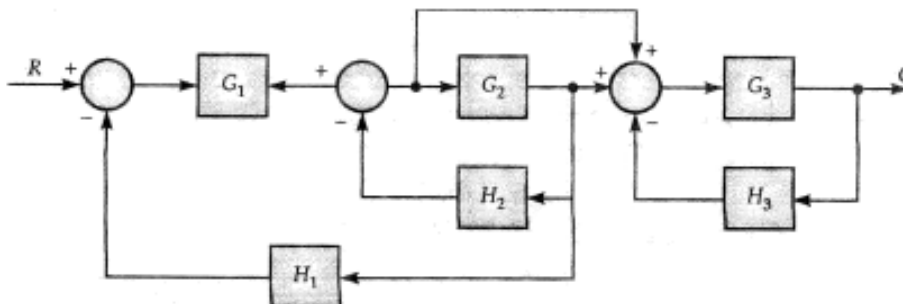



SECTION – II

7. a) Explain Engine RPM control system with accelerator as input and engine speed as output as open loop control system showing input and output and all components involved in between. **8**
- b) Explain the significance of the block diagram with the help of suitable example. **8**

OR

8. a) Define dead lag and process lag. **8**
- b) A proportional controller outputs 4 to 20 mA DC to control the motor from 0 rpm to 1440 rpm. The proportional gain is 5 and controller output at zero error is 50% of the full range and setpoint is 720 rpm. If the motor speed is 650 rpm then calculate **8**
- i) The error in % corresponding to 650 rpm
 - ii) The controller output corresponding to this error.
9. a) Define proportional plus Derivative (PD) controller along with mathematical equation. Explain the advantage of adding D control to proportional controller. What is the limitation of Derivative controller ? **6**
- b) The equation of error is $e = 0.5 t + 0.03 t^2$ with $K_P = 5$, $K_D = 0.5$ and $m(0) = 50\%$, sketch the error time and controller output vs time graph for proportional plus derivative controller from $t = 0$ to $t = 2$ sec. **10**

OR

10. a) Define the proportional band, integral action time and derivative action time. **6**
- b) The equation of error is $e = 0.5 + 0.03t$ with $K_P = 5$, $K_I = 0.5$ and $m_I(0) = 20\%$, sketch the error time and controller output vs time graph for a proportional plus integral controller from $t = 0$ to $t = 2$ sec. **10**
11. a) Write a short note on Applications of PLC in Automation. **6**
- b) Given four push to On buttons (P1, P2, S1 and S2), with two Motors (M1 and M2) write a PLC program to satisfy following objectives. **12**
- i) When P1 (Start Button) is pushed the Cycle shall start. The cycle shall continue to remain on until P2 (Stop Button) is pushed.
 - ii) When S1 is pushed then M1 is ON
 - iii) When S2 is pushed then M2 is ON
 - iv) When S1 and S2 both pushed/not pushed neither M1 nor M2 should be ON.

Draw PLC ladder diagram with PLC ladder symbols. Symbols of the physical components should not be shown in the program.

Write the names of input terminals to which switches are connected as well as output terminal names to which motors are connected.

Write the Boolean (Digital) equations with truth table of each rung you draw.

Draw the ladder diagram using only Examine ON, Examine OFF and output coil symbols.

OR



12. a) Write a short note on Counters used in PLC programming. **6**
- b) Given four push to On buttons (P1, P2, S1 and S2), with DC motor (M) write a PLC program to satisfy following objectives **12**
- i) When P1 (Start Button) is pushed the cycle shall start. The cycle shall continue to remain On until P2 (Stop Button) is pushed.
 - ii) When S1 is pushed and S2 is not pushed then Motor is ON clockwise direction.
 - iii) When S2 is pushed and S1 is not pushed then Motor is ON in counter clockwise direction.
 - iv) When P2 is pushed the program stops.

Draw PLC Ladder diagram with PLC ladder symbols. Symbols of the physical components should not be shown in the program.

Write the names of input terminals to which switches are connected as well as output terminal names to which motor is connected.

Write the Boolean (Digital) equations with truth table of each rung you draw.

Draw the ladder diagram using only Examine ON, Examine OFF and output coil symbols.



[4658] – 202

Seat No.	
----------	--

**T.E. (Civil) Examination, 2014
STRUCTURAL DESIGN – I (2003 Course)**

Time : 4 Hours

Max. Marks : 100

- Instructions :**
- 1) Attempt Q.1 or Q.2, Q.3 or Q.4 from Section I and Q.5 or Q.6, Q.7 or Q.8 from Section II.
 - 2) Answers to the **two** Sections should be written in **separate** answer books.
 - 3) **Neat** diagrams must be drawn **wherever** necessary.
 - 4) Figures to the **right** indicate **full** marks.
 - 5) Assume suitable data, if **necessary** and **clearly** state.
 - 6) **Use** of cell phone is **prohibited** in the examination hall.
 - 7) **Use** of electronic pocket calculator **IS: 800-2007** and steel table is **allowed**.

SECTION – I

1. a) Explain in brief advantage and disadvantage of steel structure. 8
- b) Design a tension member using double angle sections back to back on opposite faces of gusset plate if it carries tensile force of 250 kN. 8
- c) Determine the required weld size to connect a bracket plate to the flange of a column as shown in Fig. 1c. 9

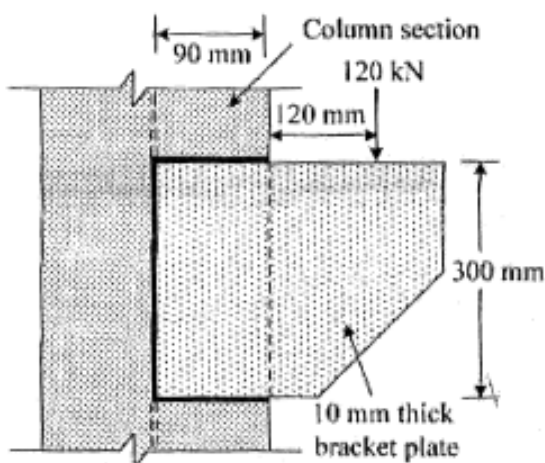

Fig. 1 c

OR

P.T.O.



2. a) Differentiate between bolted and welded connection. **6**
- b) The maximum load carrying capacities of a compression member consist of two ISA 60 mm × 60 mm × 8 mm is 150 kN. Determine the length of members. **9**
- c) An ISLB 325 @ 43.1 kg/m transmit an end reaction of 150 kN to the web of ISHB 300 @ 63 kg/m. Design the bolted connection and draw the design details. **10**
3. a) A beam is carries a uniformly distributed load of 35 kN/m on the entire span of 6 m. Design the beam using I section. Compression flange is laterally supported throughout the span. **12**
- b) A simply supported welded plate girder of span 16 m is subjected to a uniformly distributed load of 75 kN/m inclusive of its self weight. It also carries a two point loads of 100 kN each at 4 m from either ends. Design suitable cross section of girder. **13**

OR

4. a) An ISMB 450 @ 72.4 kg/m is used as a simply supported beam loaded with uniformly distributed load of 25 kN/m. Determine the effective span of the beam, if compression flange is laterally restrained throughout the span. **8**
- b) Design suitable cross section of gantry girder for the following data. **17**
- | | |
|---|----------|
| Crane capacity : | 250 kN. |
| Weight of crane excluding trolley : | 250 kN. |
| Self weight with accessories : | 250 kN. |
| Minimum approach of crane Hook to gantry girder : | 1.3 m. |
| Wheel base : | 03 m. |
| Span of crane girder : | 18 m |
| Span of gantry girder : | 06 m |
| Self weight of rail section : | 300 N/m. |

SECTION – II

5. Design the timber flooring, cross beam and central chord members of foot over bridge for the following data. **25**
- | | |
|-----------------------------|-----------------------|
| i) Type of truss: | N type |
| ii) Span of truss: | 16 m |
| iii) Spacing of cross beam: | 2 m |
| iv) Clear walking width: | 2.5 m |
| v) Live load: | 4.5 kN/m ² |
| vi) Height of truss: | 1.6 m |

OR



6. Determine the panel point dead, live and wind load for the truss shown in Fig. 6 for an industrial building located in Mumbai. The coefficient of external (c_{pe}) and internal (c_{pi}) wind pressure are 0.6 and ± 0.2 respectively. The spacing of truss is 4 m. Also design member L_0L_1 , L_0U_1 and L_1U_1 .

25

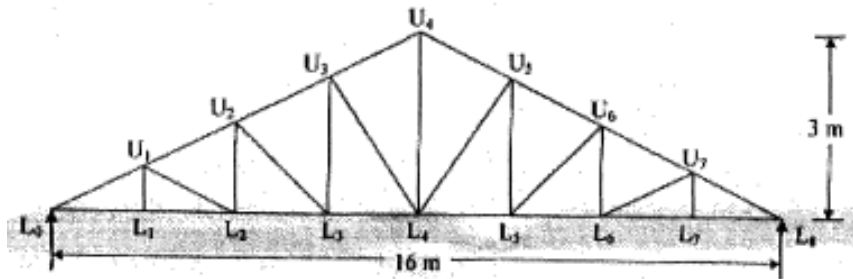

Fig. 6

7. Two channel sections ISMC 350 @ 42.1 kg/m is used as a built up column having a length of 8 m. One end of column is fixed and other end is hinged. Determine the maximum load carrying capacity of the section. Design suitable lacing system and column base for the same column. Also design the connection for lacing and column base.

25

OR

8. a) A column of 6 m effective length is carrying an axial load of 400 kN and bending moment of 50 kNm. The bearing pressure from the concrete is assumed to be 4000 kN/m². Design a suitable base and also design the anchor bolts, if required.
- b) Explain in brief the advantage and disadvantage of cold formed light gauge section.

18

7



Seat No.	
-------------	--

**T.E. (E&TC)/Electronics Examination, 2014
DIGITAL DESIGN AND COMPUTER ORGANIZATION
(2003 Course)**

Time : 3 Hours

Max. Marks : 100

- Instructions :**
- 1) Answer **any 3** questions from Section – I and **3** questions from Section – II.
 - 2) Answers to the **two** Sections should be written in **separate** answer books.
 - 3) Black figures to the **right** indicate **full** marks.
 - 4) Neat diagrams must be drawn **wherever** necessary.
 - 5) Use of logarithmic tables, slide rule, Mollier charts, electronics pocket calculator is **allowed**.
 - 6) Assume suitable data, if **necessary**.

SECTION – I

1. a) Draw ASM chart for 2 bit counter having one enable line E such that **6**
E = 1 (counting enabled)
E = 0 (counting disabled)
- b) State advantage and disadvantage of a FSM. Explain difference between Mealy and Moore machine. Compare combinational and sequential circuit. **10**

OR

2. a) Draw the ASM chart for synchronous ckt. having following description. If c = 1 on every clk. rising edge the code on o/p x, y, z changes from 000-010-100-110-000 and repeats. If c = 0 then ckt holds the present state. **8**
- b) What are the static and dynamic hazards ? Explain how static hazards are eliminated. **8**
3. a) Write VHDL code for 8 : 1 mux and explain any 2 data types in detail. **10**
- b) With suitable example explain. **8**
 - 1) Use
 - 2) Library
 - 3) Entity
 - 4) Architecture.

OR

4. a) Explain synthesis and simulation in VHDL. **6**
- b) Write VHDL code for 4 bit up/down counter and 4 bit bidirectional shift register. **12**

P.T.O.



5. a) Explain carry look ahead addition. 6
b) Carry out following :
Restoring and non-restoring division $(10)_{10}$ divide by $(3)_{10}$. 10

OR

6. a) Perform division of the following numbers using non-restoring division algorithm. 8
Dividend = 1011 ; Divisor = 0011
b) Explain Booth's algorithm for 2's compliment multiplication with the help of suitable example. 8

SECTION – II

7. a) Draw and explain 3 bus organization of the CPU. 8
b) What is subroutine nesting ? What is parameter passing ? Explain one of the methods to pass parameters. 8

OR

8. a) Explain the following : 8
i) Branching
ii) Conditional code.
b) Explain the following in brief with suitable examples. 8
i) Indirect addressing
ii) Indexed addressing.

9. a) Explain brief interrupt structure with an appropriate example w.r.t. any processor. 8
b) Explain the basic input/output operations performed by the processor. 8

OR

10. a) Explain differentiate between I/O Mapped I/O and Memory mapped I/O. 8
b) Explain the concept of following types of arbitrations 8
i) Centralised
ii) Distributed.

11. a) Explain the concept of virtual memory. How is virtual address translated to the physical address ? 10
b) Explain cache memory in detail. 8

OR

12. a) Explain functioning of CD-ROM and DVD. 8
b) Explain with a neat block diagram and timing diagram the synchronous DRAM. 10



[4658] – 24

Seat No.	
-------------	--

**T.E. (Mechanical-Sandwich) (Semester – II) Examination, 2014
THEORY OF MACHINE AND MACHINE DESIGN – II
(2008 Pattern)**

Time : 4 Hours

Max. Marks : 100

- Instructions :**
- 1) Answer **three** questions from **each** Section.
 - 2) Answers to the two Sections should be written in **separate** answer books.
 - 3) **Neat** diagrams must be drawn **wherever** necessary.
 - 4) Figures to the **right** indicate **full** marks.
 - 5) **Use** of logarithmic tables, slide rule and electronic pocket calculator is **allowed**.
 - 6) Assume suitable **data**, if necessary.

SECTION – I

Unit – I

1. A flat faced mushroom follower is operated by a uniformly rotating cam. The follower moves with cycloidal motion during the lift and returning it with uniform acceleration and retardation, acceleration being $2/3^{\text{rd}}$ of the retardation.

- Minimum radius of cam = 25 mm
- Lift of follower = 25 mm
- Angle of ascent = 120°
- Angle of descent = 120°
- Angle of dwell between ascent and decent = 30°
- Speed of cam = 300 r.p.m.

Draw the cam profile and determine maximum velocity and maximum acceleration of the follower during the lift and maximum velocity, the acceleration and retardation during return stroke.

16

OR

2. a) Synthesize the function to solve the equation $y = e^x$ for $0 \leq x \leq 4$ using three precision points chebychev spacing using graphical approach. Also determine the values of θ and ϕ if the starting positions of θ and ϕ are 40° and 50° . Also consider $\Delta\theta = 65^\circ$ and $\Delta\phi = 100^\circ$.
- b) Explain three position synthesis for four bar mechanism.

10

6

P.T.O.



Unit – II

3. a) The distance between two spur gears in mesh is 275 mm. The gear ratio is 10 : 1. The pinion transmits 360 KW at 1800 rpm. The pressure angle of the involute teeth is 20° and the addendum is 1 module. The limiting value of normal teeth pressure is 1 KN/mm of width. Determine,
- 1) Nearest standard module so that interference does not occur
 - 2) No. of teeth on each gear wheel
 - 3) Width of pinion.
- 8
- b) Explain Law of Gearing and derive the expression for velocity of sliding.
- 8

OR

4. a) The arm of an epicyclic gear train rotates at 150 r.p.m. in anticlockwise direction. The arm carries two wheels A and B having 36 and 45 teeth respectively. The wheel A is fixed and the arm rotates about the centre of wheel A. Find the speed of wheel B. What will be the speed of B, if the wheel A instead of being fixed, makes 300 r.p.m. clockwise ? Use tabular method.
- 8
- b) Explain the term interference related to gears.
- 2
- c) Compare involute and cycloidal profile of the gear teeth.
- 6

Unit – III

5. a) Derive the expression for angle of heel θ in case of stability of a two wheel vehicle under gyroscopic effect.
- 9
- b) The total mass of a four wheel trolley car is 1800 kg. The car runs on rails of 1.6 m gauge and rounds a curve of 24 m radius at 36 km/hr. The track is banked at 10° . The external diameter of the wheels is 600 mm and each pair with axle has a mass of 180 kg with radius of gyration of 240 mm. The height of the centre of mass of car above the wheel base is 950 mm. Determine the pressure on each rail allowing for centrifugal force and gyroscopic couple actions.
- 9

OR

6. a) With the help of neat sketch explain working of shoe brake.
- 5
- b) With the help of neat sketch explain working of Rope brake Dynamometer.
- 4
- c) A vehicle moves on a road that has a slope of 15° . The wheel base is 1.6 m and centre of mass is at 0.72 m from the rear wheel and 0.8 m above the inclined plane. The speed of the vehicle is 45 Km/hr and brakes are applied to all of the four wheels and the coefficient of friction is 0.4. Determine the distance moved by the vehicle before coming to rest and time taken to do so. If it move
- 1) Up the Plane
 - 2) Down the Plane.
- 9



SECTION – II

Unit – IV

7. a) Derive the velocity ratio and centre distance of helical gears with the help of sketch. **6**
- b) A pair of spur gears with a 20° full depth involute teeth consists of 21 teeth pinion meshing with a 60 teeth internal gear. The pinion shaft is directly coupled to a 7.35 kW electric motor running at 1440 rpm while the gear shaft is transmitting power to a machine. The application factor is 1.25 and the load concentration factor is 1.2. The gear pair is made of plain carbon steel 55C8 ($S_{ut} = 720$ MPa). The module and the face width are 3 mm and 35 mm respectively. The gear pair is to be heat treated to a surface hardness of 300 BHN. Assuming that the dynamic load is accounted by Barth factor, calculate
- 1) Factor of safety against bending failure
 - 2) Factor of safety against pitting failure

$$\text{Take } K = 0.16 \left(\frac{\text{BHN}}{100} \right)^2 \quad Y = 0.484 - \left(\frac{2.87}{z} \right) \quad \mathbf{12}$$

OR

8. a) A pair of straight bevel gear consists of 24 teeth pinion meshing with 48 teeth gear. The module at the outer diameter is 6 mm and face width of tooth is 50 mm. The gears are made of cast iron FG 220 ($S_{ut} = 220$ MPa). The pressure angle is 20° and the teeth are generated, the bevel pinion rotates at 300 rpm and application factor is 1.5. Assume that the velocity factor accounts for the dynamic load.
- Find :
- 1) Beam strength of the tooth
 - 2) Wear strength of tooth if surface hardness of gear pair is 250 BHN
 - 3) Static load the gears can transmit with factor of safety 2 for bending
 - 4) Rated power the gear can transmit. **12**
- b) Define the following terms in case of a worm gear with neat sketch.
- i) Axial pitch
 - ii) Lead and lead angle. **6**

Unit – V

9. a) A cone clutch is used to transmit 15 kW power at 1440 rpm. Coefficient of friction between the contacting surfaces is 0.3. The permissible intensity of pressure is 0.23 N/mm^2 . The semi cone angle is 12.5° . The mean radius of friction surface is twice the face width. Assuming uniform pressure condition. **10**
- Determine :
- 1) Dimensions of friction surfaces
 - 2) The axial force required
 - 3) Force required to disengage the clutch.



- b) Write short note on following : 6
- i) Dynamic load carrying capacity of rolling contact bearings.
 - ii) Lubrication of rolling contact bearings.

OR

10. a) A transmission shaft is supported by two deep groove ball bearings at two ends. The center distance between bearings is 160 mm. A load of 300 N acts vertically downwards at 60 mm distance from the left hand bearing whereas a load of 550 N acts horizontally at 50 mm distance from the right hand bearing. The shaft speed is 3000 rpm and expected life of the bearing is 7000 hours with a reliability of 95%. Calculate dynamic load rating of the bearing so that it can be selected from manufacturer's catalogue. 8
- b) Derive an expression for torque transmitting capacity of a single plate clutch using
- i) Uniform pressure theory
 - ii) Uniform wear theory. 8

Unit – VI

11. a) A Cantilever beam made of cold drawn steel 40C8 ($S_{ut} = 580 \text{ MPa}$ and $S_{yt} = 350 \text{ MPa}$) as shown in Fig. 01. It is subjected to load at the free end which varies from $-P$ to $3P$. The notch sensitivity factor at the fillet is 0.8. The surface finish factor and size factor are 0.85 and 0.89 respectively. The theoretical stress concentration factor is 1.5. Determine the maximum value of P such that the cantilever beam will withstand for infinite life. Take factor of safety as 2. 16

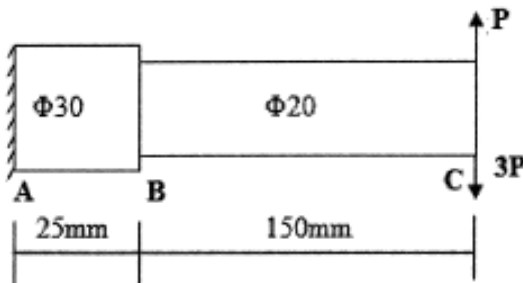

Fig. 01

OR

12. a) A forged steel bar 50 mm diameter is subjected to a completely reversed bending stress of 250 N/mm^2 . The bar is made of steel 40C8 having ultimate tensile strength of 600 N/mm^2 . The surface finish factor and size factors are 0.43 and 0.85 respectively. The required reliability is 90% for which reliability factor is 0.8. Assuming no stress concentration, determine life of bar. 10
- b) Explain Stress concentration, also explain the methods of reducing stress concentration. 6



[4658] – 32

Seat No.	
-------------	--

**T.E. (Automobile) (Semester – II) Examination, 2014
AUTOMOBILE ENGINE DESIGN
(2008 Course)**

Time : 3 Hours

Max. Marks : 100

- Instructions :** 1) Answer 3 question from Section I and 3 questions from Section II.
2) Answers to the **two** Sections should be written in **separate** answer books.
3) **Neat** diagrams must be **drawn wherever** necessary.
4) Use of logarithmic tables slide rule, Mollier charts, electronic pocket calculator and steam tables is allowed.
5) Assume suitable data, if **necessary**.

SECTION – I

1. a) Derive an expression of efficiency of Diesel cycle. 8
b) An engine working in Otto cycle has the following conditions : 8
Pressure at the beginning of compression is 1 bar and pressure at the end of compression is 11 bar. Calculate compression ratio and air standard efficiency of the engine. Assume $r = 1.4$.
- OR
2. a) Compare Otto cycle and Diesel cycle on the basis of compression ratio, peak pressure heat addition, heat rejection and network done. 6
b) In an engine working on diesel cycle inlet pressure and temperature are 1 bar and 17°C respectively pressure at the end of adiabatic compression is 35 bar. The ratio of expansion i.e. after constant pressure heat addition heat rejection and the efficiency of the cycle. 10
Assume $r = 1.4$ $C_p = 1.004$ kJ/kgK $C_v = 0.717$ kJ/kg K.

P.T.O.



3. Write a note on :
- a) Selection of firing order. 6
 - b) Selection of stroke and bore. 6
 - c) Selection of no. of cylinder. 6

OR

4. a) Explain term selection of cooling system. 6
- b) What do you mean by engine balancing ? Why it is necessary ? 6
- c) Write design considerations for combustion chamber. 6
5. a) What are the properties of lubricating oil used in IC engines ? How will you select lubricating oil for any IC engine ? 8
- b) What heat calculation is important ? Explain heat balance sheet in detail. 8

OR

6. a) Explain the terms : Mean effective pressure mechanical efficiency, brake thermal efficiency volumetric efficiency and explain the frictional losses in IC engine. 8
- b) What is function of radiator ? How will you design a radiator ? 8

SECTION – II

7. a) What is buckling of connecting rod ? 4
- b) What is the function of cylinder head and cylinder liner ? 4
- c) The following data is given for piston of a four stroke diesel engine. cylinder bore 250 mm, material of piston ring gray cast iron, allowable tensile stress = 100 N/mm^2 , allowable radial pressure on cylinder wall = 0.03 MPA thickness piston head = 42 mm no. of piston ring = 4.
- Calculate :
- 1) Radial width of piston ring.
 - 2) Axial thickness of piston ring.
 - 3) Gap between free ends of piston ring before assembly.
 - 4) Gap between free ends of piston ring after assembly.
 - 5) Width of top land.
 - 6) Width of ring grooves.
 - 7) Thickness of piston barrel and
 - 8) Thickness of piston barrel at open end. 8

OR



8. a) The following data is given for a connecting rod : 6

Engine speed = 1800 rpm, length of connecting rod = 350 mm, length of stroke 175 mm, density of material = 7800 kg/m^3 , thickness of web or flange = 8 mm. Assume cross-section as a I section and calculate whipping stress in connecting rod.

b) Write the design procedure for center crankshaft at top dead center position. 10

9. How will you measure HC and CO emission of IC engine ? Explain in detail mechanical fuel pump testing. 16

OR

10. a) Explain effect of ignition timing on engine performance. 8

b) Write a note on cylinder power balance. 8

11. Write note on :

a) Variable valve timing.

b) Variable compression ratio engine. 6

c) Wankel Engine. 6

OR

12. a) What is digital Twin Spark. Ignition (DTS-I) engine explain with advantages and disadvantages ? 8

b) Explain four valve engine with its application advantages and disadvantages. 8



Seat No.	
-------------	--

T.E. (Automobile) (Semester – II) Examination, 2014
AUTOMOTIVE TRANSMISSION
(Course 2008)

Time : 3 Hours

Max. Marks : 100

- Instructions :** 1) Answer **any three** questions from **each I** and **three** questions from **Section II**.
2) Answers to the **two** sections should be written in **separate** answer books.
3) **Neat** diagrams must be drawn **wherever** necessary.
4) **Black** figures to the **right** indicate **full** marks.
5) **Use** of logarithmic tables, slide rule, Mollier charts, electronic pocket calculator and steam tables is **allowed**.
6) Assume suitable data, if **necessary**.

SECTION – I

1. a) What are the merits and demerits of integral construction ? Write a short note on two wheeler frames. **8**
b) List out the salient features of different types of vehicle frames with neat sketches. **8**
OR
2. a) Sketch a chassis layout of articulated truck. Explain the function of each part. **8**
b) Explain electromagnetic clutch with neat sketch. Explain the lining materials used for wet clutch with their operational characteristics. **8**
3. a) What is the function of a clutch ? Discuss various factors affecting the torque transmission in a clutch. **8**
b) Explain in detail various causes of clutch troubles. How can these be remedied ? **8**
OR
4. a) What is the necessity of a gear box at all in the automobile when the engine speed can be varied by means of an accelerator ? Explain. **8**
b) Explain Overdrive with neat figure. What are its advantages and disadvantages ? **8**
5. a) Explain constant mesh gear box with neat sketch and compare with synchromesh gear box. **8**
b) A gear box with three speeds forward and one reverse is to provide the speed reduction as follows: top speed 5.5:1, intermediate 8.8:1, low 16.5:1, reverse 19.8:1 with a constant reduction at the rear axle. Assuming that the smallest pinion has not less than 15 teeth and speed of lay shaft is half that of the main driving shaft, find the suitable no. of teeth of different wheels. **10**

OR

P.T.O.



- 6. a) Explain Torque tube drive and Hotchkiss drive. 8
- b) What is gear selector mechanism ? Explain any one gear selector mechanism with its merits and demerits. 10

SECTION – II

- 7. a) Sketch general arrangement of a live rear axle and identify various loads that it has to with stand. 8
- b) Explain briefly, with neat sketches, 8
 - I) Semi floating rear axle
 - II) Three quarter floating rear axle.

OR

- 8. a) Explain non-slip differential with neat sketch. 8
- b) Explain with neat sketch working of final drive and differential unit used in automobiles. 8
- 9. a) Explain with neat sketches and characteristics. 8
 - I) Fluid flywheel
 - II) Torque converter.

- b) Explain methods of lubrication to final drive and axle shafts. 8

OR

- 10. a) Explain construction and working of Wilson Epicyclic gear train. 8
- b) Explain the principle of polyphase torque converters and relationship of speed ratio, torque ratio and efficiency for a polyphase torque converter. 8
- 11. a) Explain construction and working of Continuous Variable Transmission (CVT). 9
- b) Write note on – Clutches and brakes used in Epicyclic gear train. 9

OR

- 12. a) Explain with neat sketch construction and operating principle of automatic transmission. 9
- b) What do you mean by hydramatic transmission ? Explain in detail with neat sketch. 9

—————



[4658] – 52

Seat No.	
----------	--

T.E. (Production S/W) (Semester – II) Examination, 2014
KINEMATICS DESIGN OF MACHINES
(2008 Course)

Time : 3 Hours

Max. Marks : 100

- Instructions :** 1) Answers to the **two** Sections should be written in **separate** answer books.
2) Answer **any three** questions from each Section.
3) **Neat** diagrams must be drawn **wherever** necessary.
4) Figures to the **right** side indicate **full** marks.
5) Use of Calculator is **allowed**.
6) Assume **suitable** data if **necessary**.

SECTION – I

1. a) Explain various kinematic principles used in the operation of gear hobbing machine used to generate helical gear. 10
b) Explain the following kinematic chain representation with figure. 6
i) E-21 ii) C-13 iii) K-25

OR

2. a) Synthesize a four bar mechanism to generate a function $y = x^{1/3}$ for $1 \leq x \leq 4$ at three precision points. The crank rotates from an angle 30° to 120° where as the follower link rotates from an angle 60° to 150° . Assume length of fixed link as 60 mm. 8
b) Explain the following methods of synthesis of mechanism with figure : 8
i) Three position synthesis by Chebychev spacing.
ii) Overlay method.
3. a) Define following terms : 4
i) Notch Sensitivity ii) Fatigue
b) A steel cantilever beam shown in figure is subjected to a transverse loading at its ends that varies from 45 N up to 135 N down. Determine the required diameter at the change of cross section for finite life using a factor of safety 2.0. 12

Assume following data :

- Yield Strength = 470 N/mm²
- Ultimate tensile strength = 550 N/mm²
- Theoretical stress concentration factor = 1.63
- Notch Sensitivity = 0.8
- Reliability Factor = 0.923
- Surface finish factor = 0.9
- Size Factor = 0.85

P.T.O.

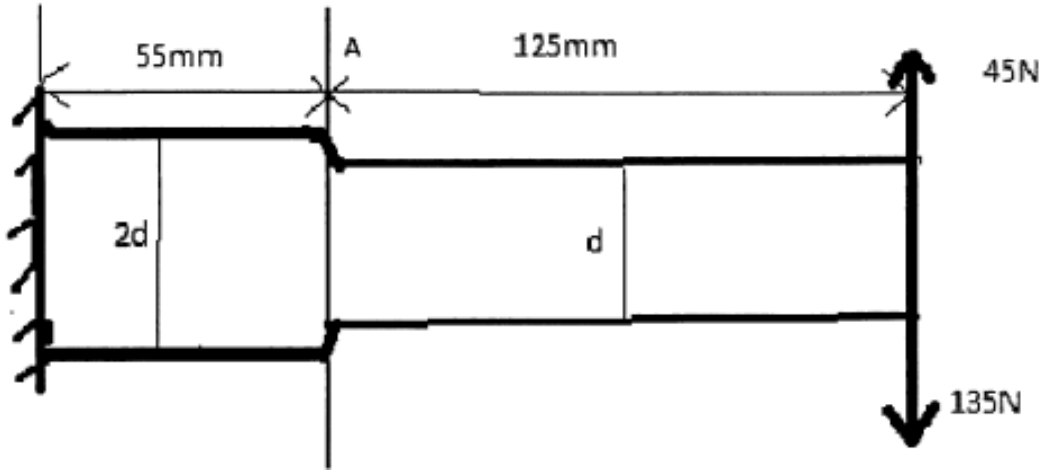

Fig. A Q3(b)

OR

4. a) What is stress concentration ? Discuss the various causes of stress concentration and various methods of reducing the effect of stress concentration. 6
- b) A cantilever beam of circular cross section is fixed at one end subjected to completely reversed force of 10 KN at the free end. The force is perpendicular to the axis of the beam. The distance between the free end and fixed end is 100 mm. The beam is made of steel with ultimate tensile strength of 540 N/mm² and tensile yield strength of 320 N/mm². The construction of the cantilever is such that there is no stress concentration. The size factor, surface finish factor and reliability factor are 0.85, 0.8 and 0.868. The temperature factor is 1.010, if the diameter of the beam is 35 mm. Determine the life of the beam. 10
5. a) A spur pinion having 20 teeth to be made up of plain carbon steel 40C8 (Sut=580 N/mm²) is to mesh with a gear having 85 teeth to be made of gray cast iron FG260. The pinion shaft is connected to 10 KW, 1440 rpm electric motor. The starting torque of the motor is approximately twice the rated torque. The tooth system is 20° full depth involute. The face width is 10 times the module for which the load distribution factor is 1.4. The gears are to be machined to meet the specification of grade 10.
- i) If the factor of safety required against bending failure is 1.5, design the gear pair by using the dynamic factor $K_v = \frac{6}{6 + v}$ and Spott's equation.
- ii) If the factor of safety required against pitting failure is 1.75. Specify the surface hardness.



Use following data :

$$\text{Lewis Factor } 0.484 - \frac{2.87}{Z}$$

$$\text{Dynamic Load } F_d = \frac{e.n.p.Z_p.b.r.p..r_g}{3259\sqrt{r_p^2 + 0.92r_g^2}} \cos \phi$$

$$K = 0.18 [\text{BHN}/100]^2 \text{ N/mm}^2$$

$$\text{For grade 10 } e = 32.0 + 2.5[m + 0.25\sqrt{d}]$$

- b) What is the significance of formative number of teeth in the design of helical gear ?

14

4

OR

6. a) Following data is given for a helical gear pair transmitting 150 KW power from a shaft rotating at 1440 rpm to parallel shaft rotating at 360 rpm.

Centre distance	= Approx. 435 mm
Helix angle	= 24°
Face width	= 14m _n
Number of teeth on pinion	= 20
Permissible bending stress for pinion material	= 152 N/mm ²
Permissible bending stress for Gear material	= 125 N/mm ²
Tooth system	= 20° full depth involute
Service factor	= 1.53
Grade of machining	= 8

Assuming the dynamic load is accounted by the Spott's Equation (Pinion is made of steel material and Gear is made of cast iron)

- The factor of safety against bending failure.
- The surface hardness, if the factor of safety against pitting failure is 1.5

Use following data :

$$\text{Dynamic Load } F_d = \frac{e.n.p.Z_p.b.r.p..r_g}{3259\sqrt{r_p^2 + 0.92r_g^2}} \cos \phi \cos \phi$$

$$\text{For grade 8 } e = 16.0 + 1.25[m + 0.25\sqrt{d}]$$

$$K = 0.18 [\text{BHN}/100]^2 \text{ N/mm}^2.$$

- b) State the difference between scoring and pitting of gear teeth.

14

4



SECTION – II

7. a) A single row deep groove ball bearing is subjected to the following work cycle.

S. N.	Fraction of cycle	Radial Load 'Fr'	Thrust Load 'Fa' KN	Radial Factor 'X'	Thrust Factor 'Y'	Race Rotating	Service Factor	Speed rpm
1	1/10	1.5	0.25	1.0	0	Inner	1.2	500
2	1/5	1.0	0.75	0.56	2.0	Outer	1.8	600
3	3/5	5.0	1.1	0.56	2.0	Inner	1.5	700
4	remaining	1.0	–	1.0	0	Outer	2.0	900

If the desired rating life of the bearing is 15000 hours; select the bearing from the following data :

Bearing No.	6011	6211	6311	6411
Dynamic capacity 'C' KN	28.1	43.6	71.5	99.5

What is the average speed of the bearing ?

12

b) What is preloading of bearing ? How it is achieved ?

6

OR

8. a) A ball bearing operates on a work cycle consisting of three parts. A radial load of 4000 N at 700 rpm for 30% of the work cycle, a radial load of 10000 N at 1550 rpm for 40 % of the cycle and radial load of 6000 N at 900 rpm for remaining part of cycle.

The basic dynamic capacity of the bearing is 40000 N. Calculate

- The rating life of the bearing in hours.
- The average speed of rotation; &
- The life of the bearing with 95% reliability.

13

b) What do you understand by antifriction bearing ? Give detailed classification of rolling contact bearing.

5



9. A punching press executes 20 holes of 20 mm diameter per minute in a plate of 15 mm thickness. This causes the variation of speed in the press flywheel from 250 rpm to 225 rpm. The punching operation takes 1.5 sec/hole. Assume 5 Nm of work to be done to shear 1 mm² of the area and that the frictional losses accounts for 15% of the work supplied for punching. Determine :

16

- i) Power needed to operate the press.
- ii) Mass of the flywheel if its mean rim radius is 0.5 m
- iii) Cross sectional area of the rim if $\rho = 7200 \text{ Kg/m}^3$

OR

10. A single cylinder, single acting, four stroke oil engine develops 20 KW at 300 rpm. The workdone by the gases during the expansion stroke is 2.3 times the workdone on the gases during the compression, and workdone during the suction and exhaust stroke is negligible. The speed is to be maintained within $\pm 1\%$. Determine the mass moment of inertia of the flywheel.

16

11. a) Explain the following terms with suitable example.

- i) Material parameter
- ii) Limited parameter
- iii) Unspecified and unlimited parameter.

10

b) Explain the difference between the design tolerance and natural tolerance. How the designer should select a tolerance for minimum rejection of component ?

6

OR

12. a) Explain the following terms used in Johnson's method of optimum design.

6

- i) Primary design equation
- ii) Subsidiary design equation.

b) The shafts are machined on two deifferent machines. From the samples of the shafts drawn from two machines, it is observed that the shaft diameters are normally distributed with a standard deviation of 0.03 mm for each of the two machines. However the mean of the shaft diameters on two machines are found to be 49.98 & 50.00 mm respectively. If the tolerance specified by the designer on the shaft diameter is $50.00 \pm 0.05 \text{ mm}$.

Determine the percentage rejection of the shaft on these machines and comment on the result.'

Z	1	1.2	1.4	1.6	1.8	
Area	0.3413	0.3849	0.4192	0.4452	0.4641	
Z	2.0	2.2	2.4	2.6	2.8	3.0
Area	0.4772	0.4861	0.4918	0.4953	0.4974	0.4987

10



Seat No.	
----------	--

**T.E. (Production S/W) (Semester – II) Examination, 2014
MATERIAL FORMING AND MOULD DESIGN
(2008 Pattern)**

Time : 3 Hours

Max. Marks : 100

- Instructions :**
- 1) Answer to the **two** Sections should be written in **separate** books.
 - 2) **Neat** diagrams must be drawn **wherever** necessary.
 - 3) Black figures to the **right** indicate **full** marks.
 - 4) **Use** of logarithmic tables, slide rule, Mollier charts, electronic pocket calculator and steam tables is **allowed**.
 - 5) Assume suitable data, if **necessary**.
 - 6) **All** questions are **compulsory**.

SECTION – I

1. a) Define true stress and true strain. Also show that true strains are additive in nature. **8**
- b) Calculate the ratio of true strain to engineering strain for the values of engineering strains of 0.001, 0.01, 0.02, 0.05, 0.1, 0.2 and 0.5. Also show for what values of engineering strain, true strains and engineering strains are equal. **8**

OR

2. a) Compare Tresca and Von Mises criterion. **6**
- b) A bar of 100 mm initial length is elongated to a length of 200 mm by the forming process in three stages. The increase in length in each stage is given below :
Stage 1 : 100 mm length increased to 150 mm.
Stage 2 : 150 mm length increased to 180 mm.
Stage 3 : 180 mm length increased to 200 mm.
 - i) Calculate engineering strain (e) and true strain (E) for each stage. Also calculate overall engineering strain and overall true strain.
 - ii) Show why true strains are more convenient than that of engineering strain. **10**
3. a) Explain forgeability and describe any one forgeability test in detail. **8**
- b) Explain following forging operations with neat sketch (**any two**). **8**
 - i) Drawing Down
 - ii) Fullering
 - iii) Edging
 - iv) Powder Metallurgy.

OR



4. a) Discuss various design considerations in Forging. 8
 b) Explain in detail, effect of grain flow lines in forging. 8
5. a) Show that the drawing stress in a wire drawing process is given by : 10

$$\frac{\sigma_d}{\sigma_o} = \left(\frac{1+B}{B} \right) \left[1 - (1-RA)^B \right]$$

where σ_d = Drawing stress

σ_o = Yield stress before drawing

R_A = Reduction in area.

- b) Write short notes on **(any two)** : 8
- i) Explosive forming
 - ii) Magnetic pulse forming
 - iii) Electro hydraulic forming.

OR

6. a) Explain wire drawing die with neat sketch. Also explain various zones of wire drawing die. Explain how lubrication is carried out in wire drawing. 10
- b) Calculate drawing load for 40% reduction in area of 50 mm × 10 mm annealed mild strip using straight tapered die having semi-die angle 26.5°, coefficient of friction is 0.1 and yield stress of material is 300 N/mm². 8

SECTION – II

7. a) For rolling process, show that : 8
 $(\Delta h)_{\max} = \mu^2 R$
 Where
 h = Draft in rolling
 μ = Coefficient of friction
 R = Roll Diameter.
- b) Determine maximum possible reduction for cold-rolling a 300 mm thick slab when coefficient of friction is 0.08 and roll diameter is 600 mm. What is the maximum reduction on same mill when $\mu = 0.5$ for hot rolling process ? 4
- c) Explain four high roll mill with neat sketch. 4

OR

8. a) A wide strip is rolled to final thickness of 6.35 mm with a reduction of 30%. The roll radius is 500 mm and coefficient of friction is 0.2. Determine the location of neutral plane. 6
- b) A 0.1% Carbon Steel strip is 50 mm wide and 5 mm thick was rolled in one pass to 3.5 mm at 1060°C. When the homogeneous yield stress was 1.05 kN/mm². The roll diameter was 340 mm. Find magnitude of rolling load, taking into account roll flattening, if rolls were made up of CI. Assume Young's modulus $E = 1.005 \text{ MN/mm}^2$. Poissons Ratio $r = 0.35$. 10



9. a) With the help of Chvorinov's equation, show that spherical casting has the maximum solidification time as compared to cubic casting and cylindrical casting. **12**
- b) Explain following for casting process (**any one**) : **4**
- i) Progressive and Directional solidification
 - ii) Elements of Gating system.
- OR
10. Explain following for Die Casting Design (**any eight**) : **16**
- i) Minimum wall thickness
 - ii) Undercuts and Ribs
 - iii) Comer radii and fillets
 - iv) Draft
 - v) Cored holes
 - vi) Combination die
 - vii) Figure showing a typical Die-casting die
 - viii) Preheating of dies
 - ix) Die-lubrication and coatings
 - x) Design of cooling system.
11. a) Explain open die forging and closed die forging with explanatory sketch. **6**
- b) For design of simple die for forging (**any four**) : **12**
- i) Types of allowances and their consideration
 - ii) Heat-transfer considerations
 - iii) Inter-cooling system
 - iv) Cam operated ejectors
 - v) Determination of cavity shapes.
- OR
12. Write short notes on following (**any three**) : **18**
- i) Type of ejectors in mould design.
 - ii) Injection molding of thermosetting plastic.
 - iii) Sketch showing mould construction.
 - iv) Cooling systems and heat transfer considerations for mould design.
-



[4658] – 54

Seat No.	
-------------	--

**T.E. (Production Sandwich Engineering) (Semester – II) Examination, 2014
PRODUCTION AND INDUSTRIAL MANAGEMENT – II
(2008 Course)**

Time : 3 Hours

Max. Marks : 100

- Instructions :** 1) Answers to the **two** Sections should be written in **separate** answer books.
2) Answer **any three** questions from **each** Section.
3) **Neat** diagrams must be drawn **wherever** necessary.
4) Figures to the **right** side indicate **full** marks.

SECTION – I

Unit – I

1. a) Explain the functions of Marketing Management. 8
b) What is Market research ? 6
c) What are the different forms of Money ? 4
- OR
2. a) What happens when an entrepreneur starts his business without conducting a market survey ? 8
b) Explain Law of Diminishing Marginal Utility. 6
c) Explain Law of Supply. 4

Unit – II

3. a) Discuss Time estimate and Time standard. 8
b) What are the functions of Process engineering ? 8
- OR
4. a) Differentiate between special purpose and General purpose machines. 8
b) What are the functions of Process engineering ? 8

Unit – III

5. a) Discuss standard tooling and special tooling. 8
b) Explain Dimensional analysis. 8
- OR
6. a) What is the Purpose and utilization of Tolerance chart ? 8
b) Explain Six Point location system. 8

P.T.O.



SECTION – II

Unit – IV

7. a) Define following terminologies : 8
1) Sampling Plan
2) Sampling Inspection
3) Lot Size
4) Sample size.
- b) Draw and explain Operation Characteristic Curve. 8
OR
8. a) Discuss Double sample plan with the help of flow chart. 8
b) What is meant by variation and discuss the reasons of variations in manufacturing ? 8

Unit – V

9. a) Explain 7 QC Tools. 12
b) What is Quality Circle ? 4
OR
10. a) Discuss in detail Total Productive Maintenance (TPM). 12
b) What is 5'S ? 4

Unit – VI

11. a) Write down the short note on Design of Experiments. 8
b) Explain Taguchi Method. 8
c) Define : Fault Tree Analysis (FTA). 2
OR
12. a) State advantage and disadvantages of ISO 9000. 8
b) State the elements of Quality System. 8
c) What is “continual improvement” ? 2
-



[4658] – 6

Seat No.	
----------	--

T.E. Civil (Semester – II) Examination, 2014
HYDROLOGY AND WATER RESOURCES ENGINEERING
(2008 Course)

Time : 3 Hours

Max. Marks :100

SECTION – I

1. a) Explain with neat sketch hydrological cycle. 4
- b) Define infiltration capacity and explain factors affecting infiltration capacity. 6
- c) Explain any two recording type of rain gauges with neat sketch. 8

OR

2. a) Define hydrology and discuss its importance in the planning of water resources projects. 4
 - b) Explain in brief different infiltration indices. 6
 - c) The following are the rates of rainfall for successive 30 min. period for a storm duration 180 minutes.
4.5, 6.0, 14.5, 12.0, 8.5, 5.0 cm/hr.
Take ϕ -index 4.0 cm/hr Calculate
i) Total rain fall
ii) W-index. 8
3. a) Define Unit hydrograph and discuss its limitations and advantages. 4
 - b) What are the methods of runoff computation ? 4
 - c) Define S-Curve hydrograph and Calculate ordinate of S-Curve hydrograph for 4hr. duration from given 2hr. UH where catchment area is 99.50 km². 8

Time (hrs.)	0	2	4	6	8	10	12	14	16	18	20
Ord. 2hr.UH (Cumecc)	0	5	14	22	28	20	18.6	12	8.5	10.1	0

OR

4. a) Define base flow and explain methods of base flow separation. 4
- b) State and explain type of precipitation 4

P.T.O.



- c) Explain the following with the help of suitable example
- | | | |
|----------------------------|----------------------|----------|
| i) Thiessen polygon method | ii) Isohytal method. | 8 |
|----------------------------|----------------------|----------|
5. a) Explain different types surveys conducted for the planning of reservoirs. **4**
- b) What are the methods of water management ? **4**
- c) Explain causes of sedimentation in reservoir. **4**
- d) How the reservoirs are classified ? **4**

OR

6. a) Define capacity of a reservoir and explain methods of determination. **4**
- b) Explain zones of storage reservoir. **4**
- c) Write a note on useful life of reservoir with reference to trap efficiency. **4**
- d) Explain mass curve diag. with the help of suitable sketch. **4**

SECTION – II

7. a) What are the factors affecting on water requirements of crops ? **5**
- b) Derive the relation between duty and delta. **5**
- c) What a Duty ? State factors affecting on it and explain methods of improving Duty. **8**

OR

8. a) Define the following terms.
- | | | |
|------------------------------|--|----------|
| i) G.C.A. | | |
| ii) C.C.A. | | |
| iii) Intensity of irrigation | | |
| iv) Capacity factor | | |
| v) Crop ratio | | |
| vi) Crop rotation. | | 6 |
- b) What is meant by frequency of irrigation ?

Determine the frequency of irrigation from the following data

- | | | |
|---|--|-----------|
| i) Field capacity 38% | | |
| ii) Permanent wilting point = 16% | | |
| iii) Density of soil 1.45g/cm ³ | | |
| iv) Depth of root zone = 60 cm | | |
| v) Readily available moisture = 80% of available moisture | | |
| vi) Daily consumptive use of water = 16 mm. | | 12 |



9. a) What are the different methods of assessment of water charges ? Explain any one . 4
b) List out methods used for determining yield of open well. Explain any one method. 4
c) What are the different methods of distribution of irrigation water ? Explain any one method. 4
d) Write down merits and demerits of Drip irrigation system. 4

OR

10. a) What are the assumptions made in the Dupuit-Thiem theory ? 4
b) An aquifer of 20 m average thk. Is overlain by an impermeable layer of 30 m thk. A test well of 0.5 m diam. and two observation wells at a distance of 10 and 60 m from the test well are drilled through aquifer. After pumping at rate of $0.1 \text{ m}^3/\text{s}$ for a long time, drawdown's stabilized. First observation 4 m and second observation 3 m. show the arrangement in a diagram. Determine the coefficient of permeability and drawdown in the test well. 8
c) Write down merits and demerits of Sprinkler irrigation system. 4
11. a) State advantages and disadvantages of irrigation and write a note on any one irrigation project in Maharashtra State. 8
b) State and explain the causes of water logging. What safety measures would you adopt to prevent water logging ? 8

OR

12. a) Explain the process of reclamation of waterlogged land. 4
b) What is meant by water logging ? State the effects of water logging. 6
c) Describe the methods of water shed management. 6



[4658] – 67

Seat No.	
-------------	--

T.E. (Electrical) (Semester – II) Examination, 2014
POWER SYSTEMS – II
(2008 Course)

Time : 3 Hours

Max. Marks : 100

SECTION – I

1. a) Derive equation for active and reactive power flow in the transmission line and prove that reactive power flow in the transmission line proportional to voltage drop along the line. 8
- b) A 3 Φ 132 kV overhead line delivers 50 MVA at 132 kV and power factor 0.8 lagging at its receiving end. The constants of line are $A = D = 0.98 \angle 3^\circ$ and $B = 110 \angle 75^\circ \Omega$, $C = 0.0005 \angle 88^\circ$. Find i) sending end voltage, current, PF and power angle ii) sending end active and reactive power. 8

OR

2. a) Explain the procedure for drawing the receiving end circle diagram. What information can be obtained from power circle diagram ? 8
- b) What is surge impedance loading ? Explain different methods used to improve surge impedance loading. 8
3. a) Explain the advantages and disadvantages of EHVAC transmission. 8
- b) How does corona occur ? What is the difference between visual critical voltage and disruptive critical voltage ? 8

OR

4. a) Estimate the corona loss for a three phase, 110 kV, 50 Hz, 150 km long transmission line consisting of three conductors each of 10 mm diameter and spaced 2.5 m apart in an equilateral triangle formation. The temperature of air is 30°C and the atmospheric pressure is 750 mm of mercury. Take the irregularity factor as 0.85. Ionization of air may be assumed to take place at a maximum voltage gradient of 30 kV/cm. 8
- b) Explain power handling capacity and power loss at different voltage levels. 8

P.T.O.



5. a) What is per unit system ? Explain the advantages and applications of per unit system. 9
- b) A 50 MVA 15 kV three phase generator has a sub transient reactance of 0.20 pu. The generator supplies two motors over transmission line having transformers at both ends, as shown in the fig. The motors have rated inputs of 30 MVA and 20 MVA, both 30 kV with 0.15 pu sub transient reactance. The rating of the sending end transformer T_1 is 50 MVA 11 Δ -132 Y with leakage reactance of 0.10 pu. Transformer T_2 at the receiving end has three single phase transformers connected as three phase unit. The rating of each individual transformer is 20 MVA, 33/76 kV with leakage reactance of 0.12 pu. Series impedance of the line is $(25 + j75 \text{ ohms})$. Draw the impedance diagram with all impedances marked in pu. Select the generator rating as the base in the generator circuit. 9

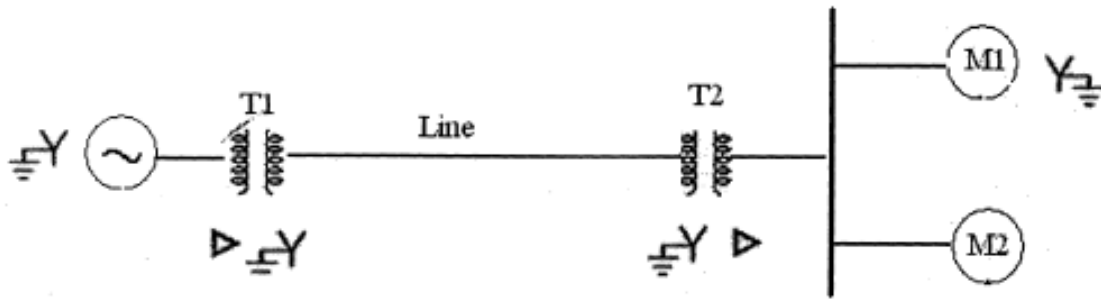

OR

6. a) Explain the concept of sub transient, transient and steady state current and impedances of unloaded alternator under symmetrical fault condition. 9
- b) A three phase transmission line operating at 33 kV and having a resistance and reactance of 5Ω and 20Ω respectively is connected to a generating station bus bar through a 15 MVA step up transformer which has a reactance of 0.08 pu. As shown in fig. Bus bar is connected to two generators one 10 MVA having 0.10 pu and another 5 MVA having 0.075 pu reactance. Calculate the short circuit MVA and the fault current when a three phase short circuit occurs at the load end of the transmission line. 9

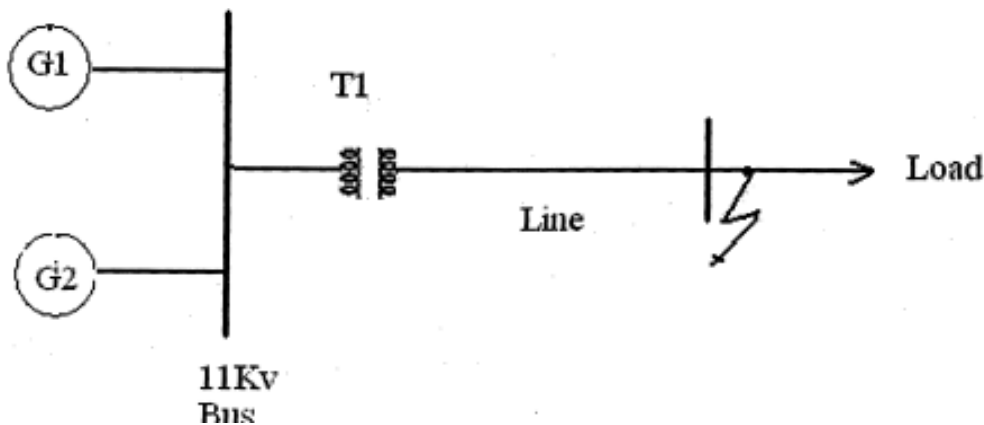



SECTION – II

7. a) Derive the expression for fault current when LLG fault occurs at the terminals of solidly grounded star connected alternator. 8

b) A 50 MVA, 11 kV, 3 phase synchronous generator was subjected to different types of faults. The fault currents are as follows :

LG fault – 4500 amp

LL fault – 3000 amp

LLL fault – 2500 amp

The generator neutral is solidly grounded. Find per unit values of 3 sequence reactance of generator. 8

OR

8. a) Show that fault current $I_f = 3E/Z_1 + Z_2 + Z_0$ when L-G fault occurs at the terminals of solidly grounded star connected alternator. 8

b) A 3 phase, 37.5 MVA, 33 kV alternator having $X_1 = 0.18$ pu, $X_2 = 0.12$ pu and $X_0 = 0.1$ pu based on its rating is connected to a 33 kV overhead line having $X_1 = 6.3 \Omega/\text{ph}$, $X_2 = 6.3 \Omega/\text{ph}$ and $X_0 = 12.6 \Omega/\text{ph}$. A single line to ground fault occur at remote end of the line. The alternator neutral is solidly grounded. Calculate fault current. 8

9. a) Derive static load flow equations for n bus system and give the classification of bus for load flow analysis. 10

b) Determine the Y bus for the three bus system. Neglect the shunt capacitances of the lines. The line series impedances are as follows. 6

Bus Code	Impedance (pu)
1 – 2	$0.08 + j 0.24$
1 – 3	$0.02 + j0.06$
2 – 3	$0.06 + j0.18$

OR



10. a) Explain in brief the procedure for formulation of Y bus using singular transformation. **8**
b) Compare Newton Raphson method with Gauss Seidal method of load flow analysis. **8**
11. a) Explain different types of HVDC links. Name any two HVDC systems in India. **10**
b) Explain constant ignition control method for HVDC transmission system. **8**

OR

12. a) Give advantages and disadvantages of HVDC transmission system. **8**
b) Explain components of HVDC transmission system with single line diagram. **10**



[4658] – 77

Seat No.	
-------------	--

**T.E. (Electronics) (Semester – II) Examination, 2014
SENSORS AND INTERFACES (2008 Pattern)**

Time : 3 Hours

Max. Marks : 100

- Instructions :**
- 1) Answer **any 3** questions from **each** Section.
 - 2) Answers to the **two** Sections should be written in **separate** books.
 - 3) **Neat** diagrams must be drawn **wherever** necessary.
 - 4) Figures to the **right** indicate **full** marks.
 - 5) Use of logarithmic tables slide rule, Mollier charts, electronic pocket calculator and steam tables is **allowed**.
 - 6) Assume suitable data, **if necessary**.

SECTION – I

1. A) i) Explain the following performance terminology of measurement system. Reproducibility, Sensitivity, Hysteresis error, Accuracy. **4**
ii) Explain the selection criterion for choosing a transducer for a particular measurement application. **4**
B) List various temperature sensors. Explain any two. **8**
OR
2. A) Explain the use of load cell for force measurement and its type. **8**
B) Explain the construction and working of absolute and incremental optical encoder. **8**
3. A) Explain the use of Wheatstone bridge and instrumentation amplifier as a signal conditioning circuit. **10**
B) Write a note on guidelines for designing an analog signal- conditioning system. **8**
OR
4. A) Explain with circuit diagram, voltage to current and current to voltage converters. **10**
B) Explain the passive circuits used in analog signal conditioning. **8**
5. A) What are the different types of ADCs ? Explain any one of them. Write a note on specifications of ADC. **8**
B) Describe working of R-2R ladder type DAC. How it is advantageous over weighted resistor DAC ? **8**

OR

P.T.O.



- 6. A) Describe working of a typical flash A/D converter for n bit operation. 8
- B) Enlist different types of DAC and give specifications of DAC. 8

SECTION – II

- 7. A) Explain the HART communication protocol in process control networks along with its modes of operation. 10
- B) Write short notes on I²C bus. 8

OR

- 8. A) Write a short note on IEEE 488 bus and field bus. 10
- B) Explain the block diagram of multichannel data logger system. 8
- 9. A) Draw and explain the symbols of following pneumatic valves. 8
 - i) 2x2 valve ii) 3x2 valve
 - iii) 4x2 valve iv) Pressure limiting valve.
- B) Explain principle of operation of stepper motor. State important specification of stepper motor. 8

OR

- 10. A) Explain the power supply system for pneumatic and hydraulic power supply. 8
- B) Explain a lift system to move the load up and down using pneumatic actuators. 8
- 11. A) With block diagram explain PLC architecture. 8
- B) Explain the PLC operating cycle. 8

OR

- 12. A) Explain current source and current sink configuration of input and output channel. 8
- B) With suitable assumptions draw the block diagram of a bottle filling plant and develop a PLC ladder diagram for the automatic operation of bottle filling plant. 8

—————



[4658] – 78

Seat No.	
-------------	--

**T.E. (Electronics) (Semester – II) Examination, 2014
MICROCOMPUTER BASED SYSTEMS
(2008 Pattern)**

Time : 3 Hours

Max. Marks : 100

- Instructions :** 1) Answer **3** questions from Section – I and **3** questions from Section – II.
2) Answers to the **two** Sections should be written in **separate** answer books.
3) **Neat** diagrams must be drawn **whenever** necessary.
4) Figures to the **right** indicate **full** marks.
5) **Use** of logarithmic tables slide rule, Mollier charts, electronic pocket calculator and steam tables is **allowed**.
6) Assume suitable data, if **necessary**.

SECTION – I

1. A) Draw CPU architecture of 8086 and explain functions of its each section. **10**
B) Explain the function of the following pins of 8086 microprocessor. **8**
i) NMI ii) READY iii) ALE iv) $\overline{\text{TEST}}$
OR
2. A) List the various addressing modes supported by 8086 and explain any four addressing modes with example. **10**
B) Explain address translation process in 8086 with suitable example. **8**
3. A) Explain with suitable examples the following instructions of 8086. **8**
i) MOVSB ii) LEA iii) ROL iv) CLC
B) Write an assembly language program of 8086 to add two 32 bit numbers. And also draw flowchart. **8**
OR
4. A) Draw interrupt vector table and explain the structure of IVT. **8**
B) Write an assembly language program of 8086 to enter a string through user and reverse it. Use suitable DOS Interrupt 21H. **8**
5. A) Enlist the salient features of 80386. **8**
B) Draw and explain the flag register of 80386 microprocessor. **8**
OR

P.T.O.



6. A) Draw and explain the paging mechanism of 80386 microprocessor. **8**
 B) What are the modes of operation of 80386 ? And explain all modes of operation. **8**

SECTION – II

7. A) Draw and explain block diagram of IBM PC Pentium based mother board. **10**
 B) Draw pins and signals of serial COM port and describe each signal. **8**

OR

8. A) List the features of USB interface and describe the different data transfer types in USB. **10**
 B) Write short notes on (**any two**) : **8**
 i) BIOS ii) PS/2 iii) Parallel port

9. A) Draw and explain ARM7TDMI core data flow model. **8**
 B) Explain the following instructions of ARM7TDMI. **8**
 i) STR ii) EOR iii) B iv) STC

OR

10. A) List and explain register structure of ARM core. **8**
 B) With the help of block diagram explain three stage pipelined instruction execution. **4**
 C) Compare FIQ and IRQ modes of ARM7 processor. **4**

11. Design 8086 based path follower using DC motors. **16**
 i) DC motors are connected through processor and 8255 I/O port with suitable driver circuit, assume suitable sensors.
 ii) Explain the important design steps operating logic.
 iii) Draw appropriate interfacing circuitry and flow chart.

OR

12. Design 8086/ARM7 based two channel data acquisition system to measure parameters like water level and temperature in process control industry. Water level range is 0 to 20 meters temperature range is 0° C to 100° C. Display these parameters on LCD. **16**
- Explain important design steps and selection criteria of components.
 - Design suitable signal conditioning circuitry.
 - Draw complete interfacing diagram using 8255 I/O port and suitable ADC. Also develop necessary flow chart.



[4658] – 88

Seat No.	
----------	--

**T.E. (E & TC) (Semester – II) Examination, 2014
COMPUTER ORGANIZATION AND ARCHITECTURE
(2008 Pattern)**

Time : 3 Hours

Max. Marks : 100

- Instructions :** 1) Answer to the **two** Sections should be written in **separate** books.
2) Neat diagrams must be drawn **wherever** necessary.
3) Figures to **right** indicate **full** marks.
4) Assume suitable data.

SECTION – I

1. a) Perform the following division using restoring and non-restoring division algorithms.
Dividend (Q) = 1110 Divisor (M) = 0100 **12**
b) Using Booth's Algorithm multiply the following :
Multiplicand = +15 Multiplier = – 6 **6**
OR
2. a) Multiply + 15 and – 10 with bit pair recoding. **8**
b) Describe IEEE standard for single precision and double precision floating pointing numbers. **4**
c) Compare Vann Neumann and Harvard Architectures. **6**
3. a) Explain different bus organization schemes of processor unit with neat diagram in brief. State its advantages and disadvantages. **8**
b) Draw and explain implementation of one bit register. **8**
OR
4. a) Explain the sequence of operations performing an arithmetic/logical operation. **8**
b) Explain the terms :
a) Data path
b) Control Memory **8**
5. a) Differentiate between Memory mapped I/O and I/O mapped I/O. **8**
b) Explain the serial port interface circuit for the processor. **8**
OR
6. a) Explain the following arbitration techniques.
a) Daisy chaining
b) Polling
c) Independent request **8**
b) What are different cache mapping techniques ? Explain any one with neat diagram. **8**

P.T.O.



SECTION – II

7. a) Explain the function of following pins of 8086. Also explain alternate function
- | | | |
|----------------------------------|-------------------------------------|----------|
| i) $\overline{MN}/\overline{MX}$ | ii) \overline{LOCK} | |
| iii) $QS_0 - QS_1$ | iv) $\overline{RQ}/\overline{GT}_0$ | 8 |
- b) Explain conditional and control flags of 8086. Also explain the instructions related to flag register modification. **10**

OR

8. a) Write an ALP using 8086 for Reversal of a string. Draw flowchart also. **8**
- b) Explain segmentation of 8086 with neat diagram. Discuss its advantages. **10**
9. a) Explain various descriptors of 80386. **8**
- b) Explain privilege levels of 80386. **8**

OR

10. a) Explain
- | | | |
|--------|------------------------------|----------|
| i) TSS | ii) Conforming code segment. | 8 |
|--------|------------------------------|----------|
- b) Explain how the logical address is converted to physical address in 80386 with paging is disabled. **8**
11. a) Explain modes of operation of ARM processor. **8**
- b) Compare RISC and CISC processors. Give examples of both. **8**

OR

12. a) Explain Flynn's classification. **8**
- b) Draw and explain Data Flow Model of ARM. **8**



[4658] – 97

Seat No.	
-------------	--

T.E. (Instrumentation and Control) (Semester – II) Examination, 2014
INSTRUMENTATION SYSTEM DESIGN
(2008 Course)

Time : 3 Hours

Max. Marks : 100

SECTION – I

1. a) What does IP stand for ? State its significance. Explain IP-54. **8**
b) Explain the phases of a product life cycle. **8**

OR

2. a) Compare following standards based on at least 4 points of differentiation : **8**
i) DIN with NEMA ii) BIN with ANSI
b) What is Ergonomics ? State and explain the three principle domains under Ergonomics. **8**
3. a) Elaborate on the mentioned types of noise-Shot noise, Thermal noise, Popcorn noise and Contact noise. **8**
b) Explain the multipoint and hybrid grounds. **8**

OR

4. a) Explain Electrostatic discharge with respect to the Human Body Model. What is tribo electric effect ? **8**
b) What is thermal noise ? Prove that thermal noise is independent of composition of resistance and thermodynamic equilibrium. **8**
5. a) Compare AD620 and AD524 based on atleast 4 points of differentiation. **4**
b) For a temperature measurement application using J type thermocouple, design and draw a circuit using suitable application ICs for following specifications :
Input temperature range: – 50°C to 100°C
Expected output voltage: 0V to + 5V **8**
c) Draw the pin diagram of XTR110 and state function of each pin. **6**

OR

6. a) Draw the pin diagram of AD620 and state the pin functions. For a temperature measurement application using NTC thermistor, design and draw a suitable circuit using AD620 for following specifications :
Input temperature range: 20°C to 80°C
Expected output voltage: 0V to +5V
Thermistor specifications : at 20°C, $R_t = 3500\ \Omega$
at 80°C, $R_t = 500\ \Omega$ **10**
b) With suitable diagrams explain how the LED characteristics are stabilized and made linear in HCNR200. **8**

P.T.O.



SECTION – II

- 7. a) Compare HCNR201 and MCT2E based on four points of differentiation. 4
- b) Using ICM7217 explain with a suitable block diagram, how it is used as a four digit Unit Counter ? 6
- c) Draw neat labeled diagrams for ULN2803 to be used to drive, 6
 - i) a relay
 - ii) a 10 mm red LED
 - iii) a 10V DC motor

OR

- 8. a) Draw the pin diagram of ICM7217. Explain the function of each pin. 6
- b) Draw and explain the pin diagram and internal block diagram of CD4046. 10
- 9. a) What are the rules followed for designing a Printing Circuit Board layout of digital circuits ? 6
- b) What are the advantages and disadvantages of solder mask ? 6
- c) What are SMD's ? 4

OR

- 10. a) State the various types of soldering techniques. Explain wave soldering. 8
- b) What are the rules followed for designing a Printing Circuit Board layout of analog circuits ? 6
- c) State the need of solder flux. 2
- 11. a) Explain intrinsic failure period of instrument by using the bath tub curve. Define MTTF and MTBF. 9
- b) How virtual instrumentation helps in collecting the computerized data in process control ? 9

OR

- 12. a) Write short note on : 10
 - i) Calibration methods
 - ii) Traceability standards
- b) Explain catastrophic failures using the failure rate curve. 8



[4658] – 98

Seat No.	
-------------	--

T.E. (Instrumentation & Control) (Semester – II) Examination, 2014
POWER PLANT INSTRUMENTATION
(2008 Course)

Time : 3 Hours

Max. Marks : 100

- Instructions :** 1) Answer **any 3** questions from **each** Section.
2) Answers to the **two** Sections should be written in **separate** books.
3) **Neat** diagrams must be drawn **wherever** necessary.
4) **Use** of logarithmic tables, slide rule, Mollier charts, electronic pocket calculator and steam tables is **allowed**.
5) Assume suitable data, if **necessary**.

SECTION – I

1. A) What is difference between unit operation and unit process ? 10
B) Explain distillation process with neat sketch. 8
OR
2. A) Explain drying unit operation. What are the different types of dryers ? Explain any one type of dryer in detail. 10
B) Explain Extraction unit operation with neat sketch. 8
3. A) Explain in detail cooling tower with neat sketch. 8
B) Explain the working of double pipe heat exchanger with neat sketch. 8
OR
4. A) Explain in detail Conduction, Convection and Radiation modes of heat transfer. 8
B) Explain evaporator with neat sketch. 8
5. A) Explain the components of Thermal power plant. 8
B) Explain the block diagram of hydro electric power plant. 8
OR
6. A) Explain Drum water level measurement in power plant. 8
B) What is smoke detector ? Explain working of smoke detector. 8

SECTION – II

7. A) Explain different safety interlocks for boiler operations. 10
B) Explain steam pressure control for boiler. 8
OR

P.T.O.



- | | |
|--|-----------|
| 8. A) Explain 1-element and 3-element drum level control for boiler operation. | 10 |
| B) Explain water tube boiler and fire tube boiler with neat diagram. | 8 |
| 9. A) Explain the procedure of startup and shutdown operation for turbine. | 8 |
| B) Explain lubricant oil temperature control for turbine with temperature. | 8 |
| OR | |
| 10. A) Explain flue gas oxygen analyzer in power plant with neat diagram. | 8 |
| B) Explain chromatography technique for power plant. | 8 |
| 11. A) Explain working of tidal power plant. | 8 |
| B) Explain instrumentation in solar power plant. | 8 |
| OR | |
| 12. A) Explain importance of instrumentation for wind power plant. | 8 |
| B) Explain working of nuclear reactor with neat sketch. | 8 |
-