

Total No. of Questions : 10]

SEAT No. :

PA-578

[Total No. of Pages : 3

[5928]-1

M.E. (Civil) (Construction & Management)

APPLICATIONS OF STATISTICAL METHODS IN CONSTRUCTION

(2017 Pattern)

Time : 3 Hours]

[Max. Marks : 50

Instructions to the candidates:

- 1) *Attempt Q.1 or Q.2, Q.3 or Q.4, Q.5 or Q.6, Q.7 or Q.8, Q.9 or Q.10.*
- 2) *Neat diagrams must be drawn wherever necessary.*
- 3) *Figures to the right indicate full marks.*
- 4) *Assume suitable data, if necessary and clearly state.*
- 5) *Use of cell phone is prohibited in the examination hall.*
- 6) *Use of electronic pocket calculator is allowed.*

Q1) a) Define probability and state its rules? [5]

- b) In a bolt factory machines M1, M2, M3 manufactures respectively 25, 35 and 40 per cent of the total. Of their output 5, 4 and 2 per cent respectively are defective bolts. One bolt is drawn at random from the product and is found to be defective. What is the probability that it is manufactured in the machine M2? [5]

OR

Q2) a) A population consists of 5 numbers 2, 3, 6, 8, 11 consider all possible samples of size 2, which can be drawn with replacement from this population. [5]

- i) The mean of the population,
 - ii) Standard deviation of population,
 - iii) The mean of the sampling distributions of means
 - iv) Standard error of means
- b) What do you mean by sampling and what are the various types of sampling. [5]

P.T.O.

- Q3)** a) A die was thrown 9000 times and of these 3220 yielded a 3 or 4. Is this consistent with the hypothesis that the die was unbiased? [5]
- b) Explain the regression analysis with suitable example with respect to construction industry. [5]

OR

- Q4)** a) If $r_{12} = 0.97$, $r_{13} = 0.93$, $r_{23} = 0.90$, find the partial correlation coefficient between x_2 and x_3 , when x_1 is held constant. [5]
- b) Explain the following: [5]
- Binomial probability distribution
 - Normal probability distribution

- Q5)** a) Explain Griffi's model with example from construction industry. Also explain the concept of Downtime cost of equipment. [5]
- b) What is simulation explain with suitable example and what is significance of random numbers? [5]

OR

- Q6)** A standardized procedure is expected to produce washers with very small deviation in their thicknesses. Suppose that 10 such washers were chosen and measured.

If the thicknesses of these washers were, in mm,

0.123, 0.133, 0.124, 0.125, 0.126, 0.128, 0.120, 0.124, 0.130, 0.126

What is a 90 percent confidence interval for the standard deviation of the thickness of a washer produced by this procedure? [10]

- Q7)** Perform sensitivity analysis for the $S = 2$, 50,000 bags, $C_o = \text{Rs. } 4000$, $C_u = \text{Rs. } 320$, $I = 22\%$. During execution it was observed that C_u reduces by 4% and remain the same, determine % change in cost. [10]

OR

Q8) Draw the ABC curve for the data given below, **[10]**

Item no.	Quantity	Consumed in a year	Cost Per Unit (Rs.)
1	2		40
2	200		5
3	30		1000
4	20		20
5	4		20
6	16		2000
7	24		50
8	5		40
9	100		8
10	250		4
11	120		8
12	140		7
13	10		10
14	20		10
15	200		5

Q9) a) Describe in brief ABC Analysis. **[5]**

b) What is EOQ? Derive the formula for EOQ. **[5]**

OR

Q10)a) Explain with neat sketch earth and rock fill cofferdam with its advantages and disadvantages. **[5]**

b) Explain Sensitivity analysis. **[5]**



Total No. of Questions : 8]

SEAT No. :

PA-587

[Total No. of Pages : 2

[5928]-10

M.E. (Civil) (Environmental Engineering)
ENVIRONMENTAL LEGISLATION AND MANAGEMENT
SYSTEMS
(2017 Pattern) (Semester - I) (501061)

Time : 3 Hours]

[Max. Marks : 50

Instructions to the candidates :

- 1) *Solve Q1 or Q2, Q3 or Q4, Q5 or Q6, Q7 or Q8.*
- 2) *Figures to the right indicate full marks.*
- 3) *Draw neat figures wherever necessary.*
- 4) *Assume suitable data, if necessary.*
- 5) *Use of scientific calculator is allowed.*

Q1) a) Write penalties for violation of consent conditions under Air Act 1981. **[4]**

b) Explain the provision relating to prevention and control in Air Act 1981. **[5]**

OR

Q2) a) Write objectives and application of ISO 14000. **[4]**

b) Write a note on Montreal Protocol. **[5]**

Q3) a) Write strategies prepared at international level to concern the environment. **[4]**

b) Write a note on Environmental Management Systems (EMS). **[5]**

OR

Q4) a) Write objectives of Environmental Protection Agency (EPA) and explain its applications. **[4]**

b) Explain citing criteria for industries. **[5]**

P.T.O.

- Q5)** a) Write powers and functions of the. MPCB board under air act. [8]
b) Write the content in the notifications issued by Govt. of Maharashtra for the protection and improvement of environment. [8]

OR

- Q6)** a) Write a note on Hazardous waste (Management and Handling) Rules, 1989. [8]
b) Write the responsibilities of waste generators and the role of Pollution Control Boards under biomedical waste rules 2016. [8]

- Q7)** a) Write the responsibilities of generators and role of Pollution Control Boards in hazardous waste management. [8]
b) Explain the role of NGO in environmental issues. [8]

OR

- Q8)** a) Write the standard guidelines and procedure of public hearing for obtaining environmental clearance. [8]
b) Write the procedure to import and export of hazardous and other waste. [8]



Total No. of Questions : 6]

SEAT No. :

PA-656

[Total No. of Pages : 2

[5928]-100

M.E. (Computer Engineering)
ARTIFICIAL INTELLIGENCE AND DATA SCIENCE
Research Methodology
(2017 Pattern) (Semester - I) (510101)

Time : 3 Hours]

[Max. Marks : 50

Instructions to the candidates:

- 1) *All questions are compulsory.*
- 2) *Figures to the right indicate full marks.*
- 3) *Draw neat diagrams wherever necessary.*

Q1) a) What is significance of Research? Enlist Research paradigms? What is meaning of the research objectives and research outcomes? **[9]**

OR

b) What is the significance of the code of ethics in research? What are various types of research? State generic research process? **[9]**

Q2) a) What is a research plan? What are generic elements to be included in Research Proposal? **[8]**

OR

b) What is the significance of following in literature survey. **[8]**

- i) Shodhganga
- ii) Bibliometrics
- iii) ResearchGate
- iv) Paraphrasing

Q3) a) What is the hypothesis and the Null hypothesis? How statistical analysis helps in testing of hypothesis? **[8]**

P.T.O.

OR

- b) State the use of the following tools : [8]
- i) NOST - Dataplot
 - ii) T-test
 - iii) ANOVA
 - iv) CAT

- Q4)** a) Differentiate between Two-Parameter Optimization and Multi-Parameter Optimization? State steps of Monte Carlo Optimization Method? [8]

OR

- b) State the simplex optimization steps? What are constraints and cost function? State the similarity and differences in simplex and gradient methods of optimization? [8]

- Q5)** a) How respondents in surveys are identified? Elaborate in brief about Survey Statements, Survey Delivery, Survey Timelines, Statistical analysis in surveys? [8]

OR

- b) When to use surveys in research? State general survey guidelines? What are ergonomic as well as human factors affecting surveys? [8]

- Q6)** a) What are various reports used for compiling research findings? Discuss the thesis organization with the significance of the appendix in the thesis? [9]

OR

- b) Elaborate following research outcomes and when which publication is to be attempted. [9]
- i) InPASS (Indian Patents Advanced Search System)
 - ii) Copyright
 - iii) Research Paper



Total No. of Questions : 7]

SEAT No. :

PA-657

[Total No. of Pages : 2

[5928]-101

M.E. (Computer Engineering)
BIO-INSPIRED OPTIMIZATION ALGORITHMS
(2017 Pattern) (Semester - I) (510102)

Time : 3 Hours]

[Max. Marks : 50

Instructions to the candidates:

- 1) *Solve any 5 from Q.No. 1 to Q.No. 7.*
- 2) *Neat diagrams must be drawn wherever necessary.*
- 3) *Figures to the right indicate full marks.*
- 4) *Assume suitable data, if necessary.*

Q1) a) Illustrate with examples, when natural computing should be used. [5]

b) Discuss scope of Artificial Immune System. [5]

Q2) a) List applications of genetic algorithm. Elaborate any one application in Details. [5]

b) Discuss philosophy of natural computing. [5]

Q3) a) Discuss selection and mutation of Evolutionary Programming. [5]

b) Define swarm intelligence. List down basic principles of swarm Intelligence. [5]

Q4) a) Discuss self tuning framework and self tuning of firefly algorithm.[5]

b) Discuss idealized rules of Cuckoo search algorithm. [5]

Q5) a) Write pseudocode of Bat algorithm. [5]

b) Discuss idealized rules of flower pollination algorithm. [5]

P.T.O.

- Q6)** a) Explain important for the development of a clonal selection algorithm. [5]
b) Write Pseudo code for Forrest's clonal selection algorithm. [5]
- Q7)** a) Describe procedure to implement the censoring phase of the real-valued negative selection algorithm. [5]
b) Summarize aiNet learning algorithm. [5]



Total No. of Questions : 8]

SEAT No. :

PA-658

[Total No. of Pages : 2

[5928]-102

M.E. (Computer Engineering)

**SOFTWARE DEVELOPMENT AND VERSION CONTROL
(2017 Pattern) (Semester - I) (510103)**

Time : 3 Hours]

[Max. Marks : 50

Instructions to the candidates:

- 1) *Attempt Q1 or Q2, Q3 or Q4, Q5 or Q6, Q7 or Q8.*
- 2) *Neat diagrams must be drawn wherever necessary.*
- 3) *Figures to the right indicate full marks.*
- 4) *Assume suitable data, if necessary.*

Q1) What is prototyping? Explain the advantages of prototyping in software development. **[9]**

OR

Q2) How evolutionary model helps in software development? Discuss its significance with an evolutionary process model. **[9]**

Q3) Explain the data centered architecture with advantages and Limitations. **[9]**

OR

Q4) Give the types of hierarchical architecture and explain. **[9]**

Q5) a) What is the importance of Software architecture? How it is used in development of software? **[8]**

b) How do you document software architecture? Explain with example. **[8]**

OR

P.T.O.

Q6) a) Explain build Engineering and its importance in Software configuration management. [8]

b) Explain any four source code management core concepts. [8]

Q7) a) Differentiate between centralized and distributed version control systems. [8]

b) Give any four version control operations. [8]

OR

Q8) a) Write short note on : [8]

i) CVS

ii) Github

b) Explain SVN version control tool [8]



Total No. of Questions : 12]

SEAT No. :

PA-659

[Total No. of Pages : 2

[5928]-103

M.E. (Computer Engineering)

EMBEDDED AND REAL TIME OPERATING SYSTEM

(2017 Pattern) (510104) (Semester - I)

Time : 3 Hours]

[Max. Marks : 50

Instructions to the candidates :

- 1) Solve Q.1 or Q.2, Q.3 or Q.4, Q.5 or Q.6, Q.7 or Q.8, Q.9 or Q.10, Q.11 or Q.12.
- 2) Neat diagrams must be drawn wherever necessary.
- 3) Figures to the right indicate full marks.
- 4) Assume suitable data, if necessary.

- Q1)** a) Explain the software tools used for embedded system development. [5]
b) Give the characteristics of embedded systems. [3]

OR

- Q2)** a) What are the challenges in the design of embedded system? [5]
b) What is the use of watchdog timer in embedded system? [3]

- Q3)** a) What are the advantages offered by an ASIP in the design of an embedded system? [4]
b) What are the common structural units in most of the processors? [4]

OR

- Q4)** a) Brief write about the ARM processor & its features. [4]
b) What factors have to be considered while selecting processor for an application? [4]

- Q5)** a) Describe serial communication devices and protocols. [5]
b) Give the brief description of SPI and SCI. [4]

OR

- Q6)** a) Explain any two Mobile System protocols. [5]
b) Enlist the differences between ISA and PCI buses. [4]

P.T.O.

- Q7)** a) Define the Release time, deadline timing constraints in Real time systems. [4]
b) Compare EDF and LST algorithms. [4]

OR

- Q8)** a) Define the Temporal parameters of real-time process. [4]
b) What is precedence graph and task graph? Give details. [4]

- Q9)** Explain the steps in priority inheritance algorithm with example. [9]

OR

- Q10)** Explain various ways of Inter-process communication-semaphores, message queues, mailboxes and pipes. [9]

- Q11)** Explain different architecture for inter process communication. [8]

OR

- Q12)** Write short notes on any two: [8]

- a) Windows CE
b) RTLinux
c) Embedded software development tools.



Total No. of Questions :10]

SEAT No. :

PA-660

[Total No. of Pages : 3

[5928]-104

M.E. (Computer Engineering)

OPERATION RESEARCH

(2017 Pattern) (Semester-II) (510108)

Time : 3 Hours]

[Max. Marks : 50

Instructions to the candidates:

- 1) *Solve any five questions.*
- 2) *Assume suitable data, if necessary.*
- 3) *Neat diagrams must be drawn wherever necessary.*
- 4) *Figures to the right indicate full marks.*

Q1) Define Non Negative constraints of Linear Programming. What are different types of solutions to linear programming problems? **[5]**

Q2) Use graph paper to solve following linear programming problem.

A furniture manufacturing company plans to make two products: Chairs and Tables, from its available resources, which consist of 400 board feet of wood and 450 man-hours. Company knows that to make a chair it requires 5 board feet and 10 man-hours and has a profit of Rs. 45, while each table uses 20 board feet and 15 man-hours and has a profit of Rs. 80. Objective is to maximize the profit. How many chairs and tables the company can make, keeping within its resource constraints? **[5]**

Q3) Solve the following using Artificial Basis Technique. **[5]**

$$\text{Max. } Z = 5X_1 + 8X_2$$

$$\text{Subject to } 3X_1 + 2X_2 \geq 3$$

$$X_1 + 4X_2 \geq 4$$

$$X_1 + X_2 \leq 5$$

$$X_1, X_2 \geq 0$$

Q4) Discuss steps of MODI method for finding optimal solution of Transportation Problem. **[5]**

P.T.O.

Q5) Calculate the optimal solution for assignment of Jobs to Machine of following cost matrix. [5]

		Machine			
		1	2	3	4
Job	1	8	7	9	9
	2	5	2	7	8
	3	6	1	4	9
	4	6	3	2	6

Q6) Calculate the optimal solution for assignment problem of following cost matrix. [5]

	I	II	III	IV	V
A	11	17	8	16	20
B	9	7	12	6	15
C	13	16	15	12	16
D	21	24	17	28	26
E	14	10	12	11	15

Q7) Solve the following 2×3 game. [5]

		P ₂		
		Y ₁	Y ₂	Y ₃
P ₁	X ₁	1	3	11
	X ₂	8	5	2

Q8) Calculate the total float, free float and independent float for the project whose activities are given below. [5]

Jobs	1-2	1-3	2-4	3-4	3-5	4-5	4-6	5-6
Duration	6	5	10	3	4	6	2	9

Q9) A decision problem has been expressed as the following pay-off table. Determine which action the executive has to choose if he adopts [5]

- a) Maximin Criterion
- b) Maximax Criterion
- c) Hurwicz Criterion with $\alpha = 0.7$
- d) Laplace Criterion
- e) Minimax Regret Criterion

Action	Events		
	I	II	III
A	10	20	26
B	-30	30	60
C	40	30	20

Q10) Discuss basic principles in sensitivity analysis. [5]



Total No. of Questions : 12]

SEAT No. :

PA-661

[Total No. of Pages : 2

[5928]-105

M.E. (Computer Engineering)
SYSTEM SIMULATION AND MODELING
(2017 Pattern) (510109) (Semester - II)

Time : 3 Hours]

[Max. Marks : 50

Instructions to the candidates:

- 1) *Neat diagrams must be drawn wherever necessary.*
- 2) *Figures to the right indicate full marks.*
- 3) *Assume suitable data, if necessary.*

Q1) a) What are basic components of System? [3]

b) What are the different ways to study the system? Explain with a diagram. [5]

OR

Q2) a) Define Simulation and when the Simulation is appropriate tool? [3]

b) Explain the Taylor method and compare it with Euler Method. [5]

Q3) a) Explain Superposition Principle with example. [4]

b) Describe the random walk and derive its Mean. [4]

OR

Q4) a) Explain general ARMA model with the help of suitable block diagram.[4]

b) Explain Moving Average (MA) processes. [4]

Q5) a) What are Disturbance signals? Explain Different Cases of Disturbance Signals. [4]

b) Explain synchronous and asynchronous Finite State Machine. [4]

OR

Q6) a) What is Petri Nets? Discuss on Standard Petri Net nomenclature. [5]

b) Explain Constraint Propagation. [3]

Q7) a) Differentiate between event and time driven systems. [4]

b) Describe M/M/1 or M/M/2 queuing model in brief. [4]

OR

P.T.O.

Q8) Consider a single-stage distributed delay with constant delay Δ . Assuming a zero initial state at $t = 0$ and unit step input, derive an explicit solution for the output $y(t)$. [8]

Q9) a) Briefly explain measures of performance for simulation system. [5]

b) Explain statistical analysis for steady state parameters. [4]

OR

Q10)a) Explain the problem of initial transient. [5]

b) Explain output analysis for termination simulation. [4]

Q11) Write short notes on [9]

a) Point estimation and Interval estimation

b) Simulation tools.

OR

Q12)a) What are the potential benefits from using simulation in manufacturing analysis? [5]

b) Explain any one simulation software used for manufacturing applications. [4]



Total No. of Questions : 6]

SEAT No. :

PA-662

[Total No. of Pages : 1

[5928]-106

M.E. (Computer Engineering)

MACHINE LEARNING

(2017 Pattern) (Semester - II) (510110)

Time : 3 Hours]

[Max. Marks : 50

Instructions to the candidates :

- 1) *All questions are compulsory.*
- 2) *Neat diagrams must be drawn wherever necessary.*
- 3) *Figures to the right indicates full marks.*
- 4) *Use of logarithmic tables slide rule, Mollier charts, electronic pocket calculator and steam tables is allowed.*

- Q1)** a) What is classification? Enlist and explain different types of classification in short. [4]
b) Differentiate predictive and descriptive learning with suitable examples. [4]
- Q2)** a) What is Dimensionality reduction? Enlist and explain any one dimension reduction method in short. [5]
b) Explain PAC learning in detail. [5]
- Q3)** a) Differentiate classification and regression with suitable example. [4]
b) What is multilayer perception? Explain in detail with suitable diagram. [4]
- Q4)** a) Explain any one rule learning algorithm with suitable rule learning process. [4]
b) Differentiate Bagging and Boosting ensemble models. [4]
- Q5)** a) Discuss Hidden marker model with suitable diagram. [4]
b) What is Bay's theorem? Explain formula of Bay's theorem. [4]
- Q6)** Write a short notes on :
a) Malicious websites detection. [4]
b) Rate vulnerabilities & predict exploits. [4]



Total No. of Questions : 8]

SEAT No. :

PA-663

[Total No. of Pages : 2

[5928]-107

M.E. (Computer Engineering)

FAULT TOLERANT SYSTEMS

(2017 Pattern) (Semester - III) (610101)

Time : 3 Hours]

[Max. Marks : 50

Instructions to the candidates:

- 1) *Neat diagrams must be drawn wherever necessary.*
- 2) *Figures to the right side indicate full marks.*
- 3) *Use of calculator is allowed.*
- 4) *Assume suitable data, if necessary.*

- Q1)** a) What are the benefits of Logical fault modeling? Explain in detail? [6]
b) Enlist and draw the Fault modeling levels from high to low level. [6]

OR

- Q2)** a) Explain how the cluster can be used to interface two nodes in Replication techniques. [6]
b) What are the measures that can be used to assess the reliability of a multi-stage interconnection network (MIN)? [6]

- Q3)** a) Explain the e-cube routing algorithm in detail? [6]
b) Explain what is the possible classification for adaptive routing algorithms in Hypercube & Mesh Networks. [6]

OR

- Q4)** a) Define BSN Connectivity? Explain BSN reliability in detail. [6]
b) Draw and explain in detail the General architecture of the HTN. [6]

- Q5)** a) Define an n-dimensional Hypercube, and explain how Hamming difference between two addresses is calculated. Draw 4-cube architecture. [6]
b) Explain how the number of hops between nodes can be reduced in Daisy-Chain Architectures? [6]

OR

P.T.O.

- Q6)** a) Draw and explain in detail Architecture-Dependent Fault Tolerance. [6]
b) Enlist the Fault-Tolerant Switching Architectures and explain in detail Extra-Stage Shuffle Exchange. [6]

- Q7)** a) Explain how Consistency of messages is maintained in Message Logging Based Checkpoints. [7]
b) Explain the concept of intergroup message sending and intragroup message sending in group communications. [7]

OR

- Q8)** a) With respect to reliable client-server communication, describe the following. [7]
i) Point-to-point communication
ii) RPC semantics in the presence of a failure.
b) Explain Byzantine Agreement Problem with Suitable example. [7]



Total No. of Questions : 12]

SEAT No. :

PA-664

[Total No. of Pages : 3

[5928] - 108

M.E. (Computer Engineering)

INFORMATION RETRIEVAL

(2017 Pattern) (Semester - III) (610102)

Time : 3 Hours]

[Max. Marks : 50

Instructions to the candidates :

- 1) *Answer Q.1 or Q.2, Q.3 or Q.4, Q.5 or Q.6, Q.7 or Q.8, Q.9 or Q.10, Q.11 or Q.12.*
- 2) *Neat diagrams must be drawn wherever necessary.*
- 3) *Figures to the right indicate full marks.*
- 4) *Assume suitable data if necessary.*
- 5) *Use of Scientific Calculator is permitted.*

Q1) a) Explain information retrieval with the help of block diagram. **[5]**

b) Explain the forms of spelling correction. **[4]**

OR

Q2) Explain K-gram index. Construct k-gram indexes for query re*ve (wild card query). **[9]**

Q3) a) What is the need of inverted file compression? **[4]**

b) Explain the variable byte code with an example **[5]**

OR

Q4) a) Explain the significance of blocked storage used for dictionary compression. **[5]**

b) Explain Zipf's law with suitable example. **[4]**

P.T.O.

Q5) Consider the following training example.

[8]

Example	DocID	Query	ST	SB	Judgement
1	34	Linux	1	1	R
2	32	Penguin	0	1	R
3	35	System	0	1	R
4	36	Mining	0	0	N
5	87	Training	1	1	R
6	54	Database	0	1	R
7	7	Linux	1	0	N

Computer weighted zone score for each (query, document) example.

OR

Q6) a) Explain the following terms :

[8]

- i) Field.
- ii) IDF.
- iii) Zone.
- iv) Term-document matrix.

Q7) a) Compute the similarity of queries Q1, Q2 with document D1 using context resemblance function.

[8]

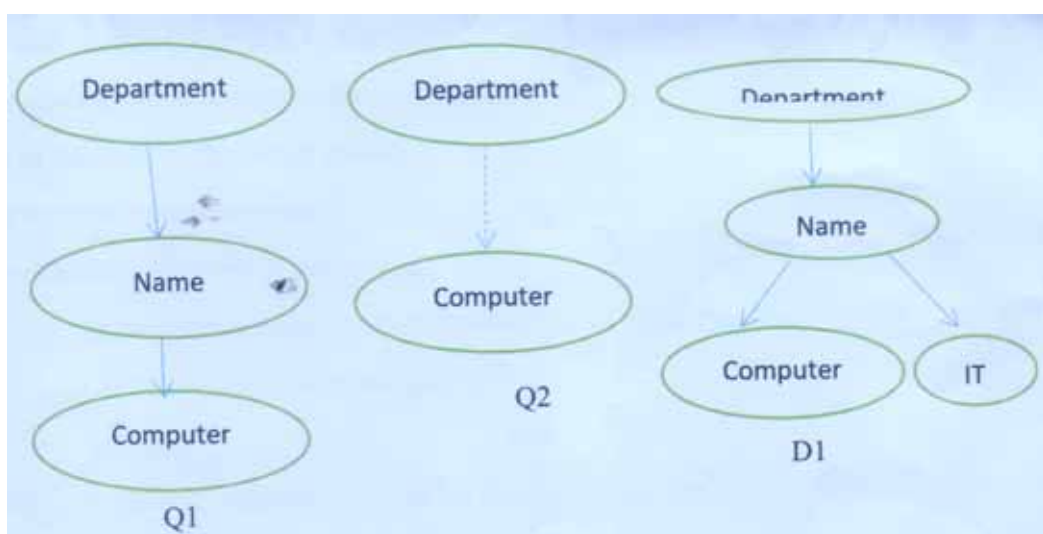

OR

Q8) Explain the need of component coverage and topical relevance in evaluation of XML document. [8]

Q9) Suppose we have collection that consists of the four documents given in the table below.

Doc Id	Document Text
1	Click go the shears boys click click click
2	Click click
3	Metal here
4	Metal shears click here

Build a query likelihood language model (unigram model) for this document collection for the query 'click shears' and rank the documents. [8]

OR

Q10) Explain the types of language models with suitable example. [8]

Q11) Compare Rocchio and k nearest classification methods by using suitable example. [8]

OR

Q12) a) Explain Single-link and complete-link clustering measures. [4]

b) How do we evaluate performance of Classification algorithms? [4]



Total No. of Questions : 12]

SEAT No. :

PA-665

[Total No. of Pages : 2

[5928]-109

M.E. (Computer) (Computer Networks)

RESEARCH METHODOLOGY

(2017 Pattern) (Semester - I) (510201)

Time : 3 Hours]

[Max. Marks : 50

Instructions to the candidates:

- 1) *Solve Q.1 or Q.2, Q.3 or Q.4, Q.5 or Q.6, Q.7 or Q.8, Q.9 or Q.10, Q.11 or Q.12.*
- 2) *Assume suitable data, wherever necessary.*
- 3) *Figures to right indicates will get full marks.*

Q1) Explain in detail the flow chart of Research Process? **[10]**

OR

Q2) Write Short Note on:

- a) Objectives of research. **[5]**
- b) Motivation in research. **[5]**

Q3) Explain Various Research grants and funding resources for research? **[8]**

OR

Q4) Explain suitable research proposal in terms of title, details budget and design for outcomes. **[8]**

Q5) Explain the various sources of error and uncertainty in measurement. **[8]**

OR

Q6) Explain One-way (or single factor) ANOVA technique? **[8]**

P.T.O.

Q7) Explain Monte Carlo optimization technique in detail? [8]

OR

Q8) Write short notes on Google Optimization Tool OpenMDAO. [8]

Q9) Explain why a good literature survey is important to narrow the research problem and the technique that might be used. [8]

OR

Q10) Explain importance of Statistical analysis and Reporting in research? [8]

Q11) Define and Explain significance of IPR, Copyright and Patents in research?[8]

OR

Q12) Explain technique of interpretation? What are precautions needed in interpretation? [8]



Total No. of Questions : 8]

SEAT No. :

PA-588

[Total No. of Pages : 2

[5928]-11

M.E. (Civil) (Environmental Engineering)
ENVIRONMENTAL CHEMISTRY AND MICROBIOLOGY
(2017 Pattern) (Semester - I) (501062)

Time : 3 Hours]

[Max. Marks : 50

Instructions to the candidates :

- 1) *Answer Q1 or Q2, Q3 or Q4, Q5 or Q6, Q7 or Q8.*
- 2) *Neat diagrams must be drawn wherever necessary.*
- 3) *Figures to the right indicate full marks.*
- 4) *Assume suitable data, if necessary and clearly state the same.*
- 5) *Use of an electronic pocket calculator is allowed.*

- Q1)** a) Explain in detail: colloidal chemistry & nuclear chemistry related to the measurement of pollution parameters. [5]
- b) Explain the importance of Environmental Chemistry in understanding waste water treatment processes. [4]

OR

- Q2)** a) State the classification of pollutants with suitable examples of each. [4]
- b) Explain in detail the physical processes of formation of pollutants in the atmosphere. [5]

- Q3)** a) Enlist the different carcinogenic compounds. [4]
- b) Discuss the general effects of carcinogenic compounds in detail. [5]

OR

- Q4)** a) Explain in detail various pollution problems caused by pesticides. [4]
- b) Discuss the problems due to DDT in detail. [5]

P.T.O.

- Q5) a)** Explain structure and function of prokaryotic cell organelles. [8]
- b) What are the Physical and Chemical properties of aflatoxin? Explain its mechanism of action. [8]

OR

- Q6) a)** Write down the application of environmental microbiology in different areas of Environmental Engineering. [8]
- b) Compare UASBR and RBC as wastewater treatment processes wrt microbiology involved in them. [8]

- Q7) a)** Explain with suitable example: Aerobic Anaerobic and Facultative Bacteria used in wastewater treatment. [9]
- b) Explain functioning of Anaerobic Digester as Unit Process wrt physical, chemical and microbial actions involved in it. [7]

OR

- Q8) a)** What are biogeochemical cycles? Explain atmospheric cycle in detail? [8]
- b) Explain in detail: role of microbes in aeration tank and SST of a conventional waste water treatment plant. [8]



Total No. of Questions : 7]

SEAT No. :

PA-666

[Total No. of Pages : 1

[5928]-110

M.E. (Computer Engineering) (Computer Networks)

NETWORK SECURITY

(2017 Pattern) (510202)(Semester-I)

Time : 3 Hours]

[Max. Marks : 50

Instructions to the candidates:

- 1) *Q. No. 7 is compulsory, solve any five from Q. No. 1 to Q. No. 6.*
- 2) *Figure to the right indicates full marks.*
- 3) *Neat diagrams must be drawn wherever necessary.*
- 4) *Assume suitable data, if necessary.*

Q1) What is network sniffing? Explain tools used for network sniffing. Why is network sniffing useful? **[8]**

Q2) What is hacking? Explain the hacking process in detail. What are different Ethical hacking issued? **[8]**

Q3) Write short notes on - **[8]**
a) Spoofing and decoy scans.
b) Evading Firewalls.

Q4) What are web injections? How SQL injections work? Which are different categories for the types of attack using SQL injections. **[8]**

Q5) What is hash? What is the problem with windows NTLM? Which tool is used insist of windows NTLM for authentication? Explain in detail. **[8]**

Q6) How VLAN hopping attack is executed? State & explain the consequences of VLAN Hopping. **[8]**

Q7) What is confidentiality Attacks in WiFi? Can Wireshark be used as tools for confidentiality? If yes explain how? **[10]**



Total No. of Questions : 8]

SEAT No. :

PA-667

[Total No. of Pages : 2

[5928]-111

M.E. (Computer Networks)

WIRELESS SENSOR NETWORKS

(2017 Pattern) (Semester - I) (510203)

Time : 3 Hours]

[Max. Marks : 50

Instructions to the candidates:

- 1) *All questions are compulsory.*
- 2) *Neat diagrams must be drawn wherever necessary.*
- 3) *Assume suitable data, if necessary.*

- Q1)** a) Explain One-shot interactions using Disseminating big data sets via SPIN.[6]
b) Explain Data-centric storage with operation of geographic hash tables.[6]

OR

- Q2)** a) Explain Application-Specific Integrated Circuit (ASIC) with its basic building blocks, also discuss Advantages, Disadvantages and Applications of ASICs. [6]
b) Draw the Architecture of a wireless sensor node and explain sensing subsystem in detail. [6]

- Q3)** a) Describe LEACH operations a setup phase and a steady-state phase with figure. [6]
b) Explain main Characteristics of MAC Protocols in Sensor Networks.[6]

OR

- Q4)** a) Explain most important Properties of localization and positioning procedures. [6]
b) Explain possible approaches exists to determine a node's position in wireless networks. [6]

P.T.O.

Q5) a) Explain Open-loop and closed loop mechanisms used by Congestion Detection and Avoidance (CODA) approach. [7]

b) Explain Single packet delivery using multiple paths by providing alternative routes, ReInForM, HHB and HHBA. [6]

OR

Q6) a) RMST is designed toward guaranteed delivery of large blocks of data from sensors to sinks, while design of RMST what repair mechanisms required on different layers. [6]

b) Explain Mechanisms for congestion detection and congestion handling in WSN. [7]

Q7) a) Explain with figure Examples of attacks and the CIA model. [6]

b) Discuss various Challenges of providing Security in Wireless Sensor Networks. [7]

OR

Q8) Write short Notes on (Any Two): [13]

a) Security Protocol for Sensor Networks-TinySec.

b) Physical Layer and Link layer DoS attacks.

c) Security attacks on Data Aggregation and Privacy Attacks.



Total No. of Questions : 12]

SEAT No. :

PA-669

[Total No. of Pages : 2

[5928] - 115

M.E. (Computer) (Computer Network)

DATA ALGORITHMS

(2017 Pattern) (Semester - II) (510210)

Time : 3 Hours]

[Max. Marks : 50

Instructions to the candidates :

- 1) *Answer Q.1 or Q.2, Q.3 or Q.4, Q.5 or Q.6, Q.7 or Q.8, Q.9 or Q.10, Q.11 or Q.12.*
- 2) *Neat diagrams must be drawn wherever necessary.*
- 3) *Figures to the right indicate full marks.*
- 4) *Assume suitable data, if necessary.*

Q1) Explain different options of spark solution for secondary sort with suitable example. **[8]**

OR

Q2) In secondary sorted, Give the example of your choice to explain the following terms and their importance : Logical (Key, value) pair, Natural key, Natural value and composite key. **[8]**

Q3) What is left outer join operations in database? What is significance of left outer join in real world situation? Give suitable SQL for the same. With the help of SQL explain what is mean by Left in left outer join. **[8]**

OR

Q4) Left Outer Join $(T_1, T_2, K) = \{(k, t_1, t_2) \text{ where } k \in T_1.K \text{ and } k \in T_2.K\}$

$\cup \{(k, t_1, null) \text{ where } k \in T_1.K \text{ and } k \notin T_2.K\}$

Above is the given a mathematical definition in term of set theory for left outer join.

What K, T_1 and T_2 signifies, take suitable example and explain? **[8]**

P.T.O.

Q5) What is Order inversion? Write down code for order inversion and In what sense does it invert order? Give the advantages of order inversion. [9]

OR

Q6) “One can sort the input data and then easily select the K largest records from the sorted file. This is often the most efficient method for very large K” to implement this sort give the construct of Map and Reduce functions. [9]

Q7) What is market basket analysis? What are the association rules? What is the role of association rules in market basket analysis? In the following example calculate support, confidence and lift [8]

* Assume there are 100 customers

* 10 of them bought milk, 8 bought butter and 6 bought both of these.

OR

Q8) What is the purpose of market basket analysis? Give suitable example of application and explain market basket analysis using spark. [8]

Q9) Explain in brief five method template for implementing scatter search. [9]

OR

Q10) What is the scatter search algorithm? What are its characteristics? And Give the algorithmic procedure. [9]

Q11) Explain Bellman’s equation and acyclic graph. What is significance of bellman’s equation in shortest path finding? [8]

OR

Q12) Apply The Min Cost Flow Linear Program using network simplex method for the following graph to find the network linear program. [8]

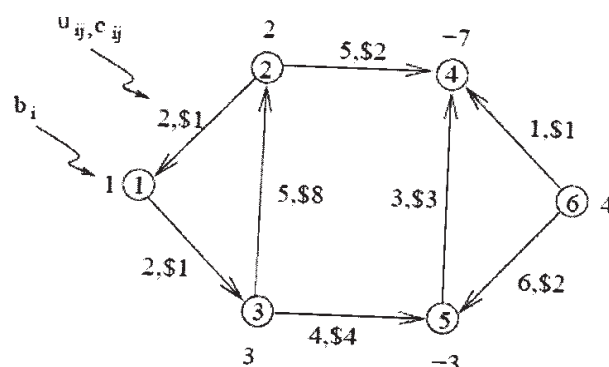

Total No. of Questions : 12]

SEAT No. :

PA-670

[Total No. of Pages : 2

[5928]-116

M.E. (Computer Networks)

FAULT TOLERANT SYSTEMS

(2017 Pattern) (Semester - III) (610201)

Time : 3 Hours]

[Max. Marks : 50

Instructions to the candidates:

- 1) *Answer six questions.*
- 2) *Neat diagram must be drawn wherever necessary.*
- 3) *Figures to the right side of question indicate full marks.*

Q1) Explain various error correction codes in detail with examples? **[9]**

OR

Q2) Explain Combinatorial (Continuous) Model in detail with example? **[9]**

Q3) Explain in detail about Sequential Fault Diagnosis Methods? **[9]**

OR

Q4) What is fault modeling? Explain fault modeling levels in detail? **[9]**

Q5) Explain Depth-First Search routing algorithm for fault tolerant in Hypercube?[8]

OR

Q6) Explain Message Routing Based on Current Node, Destination Node and Flag Bits with algorithms? **[8]**

Q7) What is Hierarchical Cubic Network (HCN)? Explain HCN (2, 2) network in detail with diagram? **[8]**

OR

Q8) Explain Edges Groups, Construction, Degree and Diameter in detail? **[8]**

P.T.O.

Q9) Explain various Classifications of Fault-Tolerant Switching Architectures? **[8]**

OR

Q10)What is fault tolerance? Explain in detail? **[8]**

Q11)Compare issues in various checkpoint schemes for wireless networks? **[8]**

OR

Q12)Explain the following terms **[8]**

- i) Faults
- ii) Errors
- iii) Failures
- iv) Pocess resilience



Total No. of Questions : 8]

SEAT No. :

PA-671

[Total No. of Pages : 2

[5928]-117

M.E. (Computer Networks)

MOBILE AD HOC NETWORKS

(2017 Pattern) (Semester - III) (610202)

Time : 3 Hours]

[Max. Marks : 50

Instructions to the candidates :

- 1) *All questions are compulsory.*
- 2) *Neat diagrams must be drawn wherever necessary.*
- 3) *Assume suitable data, if necessary.*

- Q1)** a) Compare the pros and cons of using scheduling-based MAC protocols over reservation based MAC protocols. [6]
- b) Why TCP is not suitable in wireless environment? Compare Snoop TCP and Indirect TCP. [6]

OR

- Q2)** a) What are the issues in designing a MAC protocol for ADHOC wireless networks? Explain any one in detail. [6]
- b) What are the various steps involved in a handoff? State the differences between network-initiated and mobile-initiated handoffs. [6]

- Q3)** a) What are the advantages of multicast routing protocols based on Zone routing? [6]
- b) Why energy management is necessary in ad hoc wireless networks? Classify energy management schemes in ad hoc wireless networks. [6]

OR

- Q4)** a) Explain various network layer attacks in ADHOC wireless networks. [6]
- b) What do you mean by path rerouting and path maintenance? [6]

P.T.O.

- Q5)** a) Compare wireless sensor network and ADHOC wireless networks. [7]
b) Explain Multi-hop Cellular networks (MCN) best effort architecture. [6]

OR

- Q6)** a) List the various data dissemination methods in sensor network. Explain any one in details. [6]
b) Explain Low Energy Adaptive Clustering Hierarchy (LEACH) network architecture. [7]

- Q7)** a) What are the major factors to be considered while selecting a light source for designing a mobile network using optical wireless technology? [7]
b) What are the important features that make the UWB systems applicable for high-speed mobile communications? [6]

OR

- Q8)** Write Short Notes on (Any Two) : [13]
a) Advantages and Disadvantages of UWB.
b) Bandwidth-Conscious MNs.
c) Optical Wireless WDM.



[5928]-118

M.E. (A.I & D.S./Computer)

MATHEMATICAL FOUNDATION FOR DATA

SCIENCE (2017 Pattern) (Semester - I) (510301)

Time : 3 Hours]

[Max. Marks : 50

Instructions to the candidates:

- 1) Answer Q.1 or Q.2, Q.3 or Q.4, Q.5 or Q.6, Q.7 or Q.8, Q.9 or Q.10, Q.11 or Q.12.
- 2) Neat diagrams must be drawn wherever necessary.
- 3) Figures to the right indicate full marks.
- 4) Assume suitable data, if necessary.

Q1) a) In a group of 100 persons, 72 people can speak English and 43 can speak French. How many can speak English only? How many can speak French only and how many can speak both English and French? [3]

b) Represent the given Graph using adjacency list or Adjacency Matrix. Write Depth First Search Traversal of given graph considering 2 as starting vertex. [6]

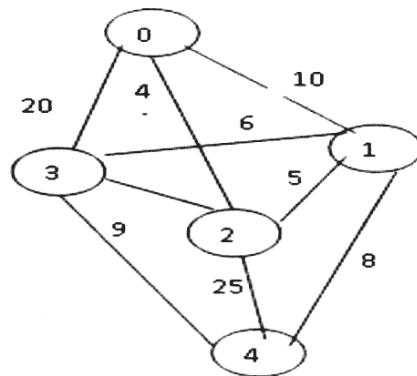

OR

Q2) a) Prove the following by using Venn diagram. [6]

i) $(A \cap B) \cap C = A \cap (B \cap C)$

ii) $A \cup (B \cap C) = (A \cup B) \cap (A \cup C)$

b) The following numbers are inserted into an empty binary search tree in the given order: 20, 10, 30, 50, 15, 12, 16, 40, 14. Construct tree and write its Inorder traversal. [3]

P.T.O.

Q3) a) For given attribute marks values: [4]

13, 15, 16, 16, 19, 20, 20, 21, 22, 22, 25, 25, 25, 25, 30, 33, 33, 35, 35, 35, 35, 36, 40, 45, 46, 52, 70. Compute mean, median, mode, standard deviation.

b) Compare Poisson distribution and Binomial distribution. [4]

OR

Q4) a) Explain following for numerical data using example: [6]

i) Quantile

ii) Five Number summary

b) A bag contains 2 white balls, 3 black balls and 4 red balls. In how many ways can 3 balls be drawn from the bag, if at least one black ball is to be included in the draw? [2]

Q5) a) For given attribute marks values: [5]

10, 90, 30, 20, 50, 30, 60, 40, 70, 40, 30, 60, 80, 20

Compute standard deviation, Range, Inter Quartile Range (IQR), five number summary plot it using boxplot.

b) Explain concept and application of Skewness & Kurtosis. [4]

OR

Q6) a) Compute covariance of age and glucose values given below: [4]

(Age - 1.5, 2, 1.6, 1.2, 1.1)

(Glucose - 1.7, 1.9, 1.8, 1.5, 1)

b) Explain any two graphical representation methods for qualitative data.[5]

Q7) a) Use these methods to normalize the following group of data: [4]

20, 30, 40, 60, 100

i) z-score normalization

ii) z-score normalization using the mean absolute deviation instead of standard deviation

b) Explain any one Probabilistic models with hidden variables using example.[4]

OR

Q8) a) Find correlation of following data set $x = \{2, 5, 6, 8, 9\}$, $y = \{4, 3, 7, 5, 6\}$. [3]

b) Consider following dataset, predict the class label using Naive Bayesian classification for tuple (Yes, No, Male, Yes, B). [5]

Owens home	Married	Gender	Employed	Credit rating	Risk class
Yes	Yes	Male	Yes	A	B
No	No	Female	Yes	A	A
Yes	Yes	Female	Yes	B	C
Yes	No	Male	No	B	B
No	Yes	Female	Yes	B	C
No	No	Female	Yes	B	A
No	No	Male	No	B	B
Yes	No	Female	Yes	A	A
No	Yes	Female	Yes	A	C
Yes	Yes	Female	Yes	A	C

Q9) a) Solve the following system of equations using matrix Decomposition method: [4]

$$X_1 + X_2 + X_3 = 1, 4X_1 + 3X_2 - X_3 = 6, 3X_1 + 5X_2 + 3X_3 = 4$$

b) Explain one application of Jacobian Matrix. [4]

OR

Q10)a) Find the eigenvalues of the matrix: [4]

$$\begin{bmatrix} 2 & 2 \\ 5 & -1 \end{bmatrix}$$

b) Explain two forms of Chain Rule. [4]

Q11)a) Overfitting and Multicollinearity with respect to regression. [4]

b) Find linear regression equation for the following two sets of data: [4]

X	1	2	3	4	5	6	7
Y	9	8	10	12	11	13	14

OR

Q12) Suppose we have the following dataset with one response variable Y and two predictor variables X1 and X2. Fit a multiple linear regression model to this dataset. [8]

X1	60	62	67	70	71	72	75	78
X2	22	25	24	20	15	14	14	11
Y	140	155	159	179	192	200	212	215



Total No. of Questions : 12]

SEAT No. :

PA-673

[Total No. of Pages : 3

[5928]-119

M.E. (Computer Engineering) (Data Science)

BASICS OF DATA SCIENCE

(2017 Pattern) (Semester - I) (510302)

Time : 3 Hours]

[Max. Marks : 50

Instructions to the candidates:

- 1) *Answer Q.1 or Q.2, Q.3 or Q.4, Q.5 or Q.6, Q.7 or Q.8, Q.9 or Q.10, Q.11 or Q.12.*
- 2) *Neat diagrams must be drawn wherever necessary.*
- 3) *Figures to the right indicate full marks.*
- 4) *Assume suitable data, if necessary.*
- 5) *Use of logarithmic tables slide rule, mollier charts electronic pocket calculator and steam tables is allowed.*

Q1) a) What is data science? Explain first two steps involved in data science process. **[5]**

- b) Differentiate between - **[4]**
- i) Structured Data and Unstructured Data
 - ii) Big Data and Little Data

OR

Q2) a) What is the role of a Data Scientist in the industry? **[5]**

- b) Explain following steps involved in data science process. **[4]**
- i) Data preparation
 - ii) Data exploration

Q3) What is data distribution? Explain following representation of a distribution with exmample. **[8]**

- a) Probability Mass Function
- b) Cumulative Distribution Function

OR

Q4) Explain Summarizing the Data in EDA process in detail with example. **[8]**

P.T.O.

Q5) Write K-nearest Neighbors algorithm. Suppose you have given the following data where weight and y are the height input variables and Class is the dependent variable. **[9]**

Weight	height	Class
51	167	underweight
62	182	normal
69	176	normal
64	173	normal
65	172	normal
56	174	underweight
58	169	normal
57	173	normal
55	170	normal

Apply KNN algorithm to predict the class of new data point weight = 57 kg and height = 170 cm using Euclidean distance. Assume $k = 3$.

OR

Q6) Write K means algorithm. Using k-means algorithm, cluster following data into two clusters. Show each step of clustering. **[9]**

X	Y
185	72
170	56
168	60
179	68
182	72
188	77

- Q7) a)** What is data visualization and explain for what it used for? [4]
b) Explain following bivariate data visualization techniques. [4]
 i) Bar plot
 ii) Scatter plot

OR

- Q8) a)** What is data visualization? Explain different types of visualization. [6]
b) Explain data encoding in detail. [2]

- Q9) a)** Below is a utility matrix representing ratings by users A, B, C, D, E and F for items *a* through *f*. Calculate the Jaccard distance between item *a* and *b*. [4]

User\Item	<i>a</i>	<i>b</i>	<i>c</i>	<i>d</i>	<i>e</i>	<i>f</i>
A	1	1	0	0	0	0
B	1	1	1	0	0	0
C	1	0	0	0	0	0
D	0	1	0	1	0	0
E	0	0	0	0	1	1
F	0	0	0	0	1	1

- b)** What is utility matrix in recommendation system? Explain key problems for recommender system to figure out values in utility matrix. [4]

OR

- Q10)** What is a Collaborative-Filtering based recommendation system? Explain the advantages and disadvantages of Collaborative-Filtering based recommendation system. [8]

- Q11)** What is social network? What are the essential characteristics of a social network. [8]

OR

- Q12)** Explain Girvan-Newman Algorithm with example. [8]



Total No. of Questions : 16]

SEAT No. :

PA-589

[Total No. of Pages : 2

[5928]-12

M.E. (Civil) (Environmental Engineering)
PHYSICO - CHEMICAL PROCESS FOR WATER AND
WASTEWATER TREATMENT
(2017 Pattern) (Semester - I) (501063)

Time : 3 Hours]

[Max. Marks : 50

Instructions to the candidates :

- 1) *Solve Q1 or Q2, Q3 or Q4, Q5 or Q6, Q7 or Q8, Q9 or Q10, Q11 or Q12, Q13 or Q14, Q15 or Q16.*
- 2) *Figures to the right indicate full marks.*
- 3) *Your answers will be valued as a whole.*
- 4) *Assume suitable data, if necessary.*

Q1) Enlist and discuss any one of the reactors that are used for waste water treatment. **[5]**

OR

Q2) It is required to prepare 1250 kg of a solution composed of 12 wt.% ethanol and 88 wt.% water. Two solutions are available, the first contains 5 wt.% ethanol, and the second contains 25 wt.% ethanol. How much of each solution are mixed to prepare the desired solution? **[5]**

Q3) Why is Aeration Important for Wastewater Treatment? **[5]**

OR

Q4) Design a tube settler for increasing the capacity of an existing settling tank provided for a water treatment plant (WTP) from 0.1314–0.3285 m³/s. The existing tank dimensions are 9.14 m × 39.62 m × 3.66 m. Raw water has a turbidity of 20–25 JTU and temperature of up to 4.4°C. Effluent turbidity desired is 1–5 JTU. **[5]**

Q5) Discuss the Energy of interaction between two colloidal particles in the form of attraction by van der Waals' forces and repulsion by electrostatic forces. **[5]**

OR

P.T.O.

Q6) Water receiving an average degree of pretreatment and responding in average fashion to coagulation is to be filtered at a rate of 122 L/min/m² through a layer of sand grains 0.1 cm in diameter. Find the requisite minimal depth of sand that will prevent breakthrough of turbidity at a terminal loss of head of 2.44 m. Take value of the breakthrough index as 1×10^{-3} . [5]

Q7) Draw and discuss the generalised biological process reaction in the Activated Sludge Process. [5]

OR

Q8) Discuss in details about Tube-Type Clarifier Package Plants. [5]

Q9) Discuss the influence of temperature and hydrogen ion concentration on anaerobic digestion. [7]

OR

Q10) Discuss the four interacting microbial reactions in anaerobic digestion. [7]

Q11) What is importance of Nutrient Balance in Anaerobic Digesters? [7]

OR

Q12) Explain how microbial growth is a function of substrate concentration. [7]

Q13) Enlist and discuss the Oxidizing agents useful in Water and Wastewater Treatment. [8]

OR

Q14) Explain in detail the thermodynamics of redox reactions. [8]

Q15) What are the types of RO membrane modules? Discuss any one in detail. [8]

OR

Q16) Give note on : [8]

- a) Concentration Factor
- b) Osmotic Gradient
- c) Osmotic Pressure
- d) Tonicity



Total No. of Questions : 12]

SEAT No. :

PA-674

[Total No. of Pages : 2

[5928]-120

M.E. (Computer) (Data Science)

BIG DATA ANALYTICS

(2017 Pattern) (Semester - I) (510303)

Time : 3 Hours]

[Max. Marks : 50

Instructions to the candidates:

- 1) *Answer Q.1 or Q.2, Q.3 or Q.4, Q.5 or Q.6, Q.7 or Q.8, Q.9 or Q.10, Q.11 or Q.12.*
- 2) *Neat diagrams must be drawn wherever necessary.*
- 3) *Figures to the right indicate full marks.*
- 4) *Assume suitable data, if necessary.*
- 5) *Use of logarithmic tables slide rule. Mollier charts, electronics pocket calculator and stream tables is allowed.*

Q1) Define Big Data Analytics? What are different Tools used for Big Data Analytics? Explain with suitable example. **[9]**

OR

Q2) List the key roles for a successful analytics project. Explain the following roles in details with example. **[9]**

- a) Data Engineer
- b) Data Scientist

Q3) Define Distributed Computing. Explain the working of a distributed computing environment with appropriate diagram. **[9]**

OR

Q4) Explain the working of APache Hadoop with suitable components and architecture diagram. **[9]**

P.T.O.

Q5) Compare Pig and Hive. Explain different execution modes available in Pig. Explain in brief the applications of PIG. [8]

OR

Q6) Describe Apache Zookeeper. Explain the working of Apache Zookeeper in brief and List the benefits of the same in Big Data problems. [8]

Q7) Explain how Spark runs applications with the help of its architecture and suitable example. [8]

OR

Q8) What is Apache Spark RDD? Why do we need RDD in Spark? Explain different Features of Spark RDD in detail. [8]

Q9) Describe role of PySpark in Big Data Analytics. Explain the various PySpark persistence levels in details. [8]

OR

Q10) What different cluster managers does Apache Spark offer? Briefly explain each. [8]

Q11) List the major challenges of Data Visualization. Visualization is a fantastic tool for understanding, analyzing, and sharing information. Justify the statement. [8]

OR

Q12) Describe Big Data Visualization? What is the Need for advanced visualization techniques in big data? [8]



Total No. of Questions : 12]

SEAT No. :

PA-675

[Total No. of Pages : 2

[5928]-121

M.E. (Computer Engineering) (Master of Data Science) (Artificial Intelligence & Data Science)

**RESEARCH METHODOLOGY
(2017 Pattern) (Semester - I) (510101)**

Time : 3 Hours]

[Max. Marks : 50

Instructions to the candidates:

- 1) *Answer Q.1 or Q.2, Q.3 or Q.4, Q.5 or Q.6, Q.7 or Q.8, Q.9 or Q.10, Q.11 or Q.12.*
- 2) *Assume suitable data, if necessary.*
- 3) *Neat diagrams must be drawn wherever necessary.*
- 4) *Figures to the right indicate full marks.*

Q1) a) Describe the techniques for defining a research problem. [5]

b) Compare qualitative and quantitative research. [4]

OR

Q2) Briefly describe the different steps involved in a research process. [9]

Q3) Explain the research proposal elements with a simple case study. [9]

OR

Q4) Explain the role of: [9]

- a) Paper and book publications in research work.
- b) E resources for collecting research papers of related work.
- c) Literature review.

P.T.O.

Q5) Find the coefficient of correlation between X and Y for the following data
Coefficient of correlation between X and Y for the following data. [8]

X	1	2	3	4	5	6	7	8	9
Y	10	11	12	14	13	15	16	17	18

OR

Q6) Explain with example: [8]

- a) Type I error
- b) Type II error
- c) Confidence level

Q7) Explain need and working of Monte Carlo optimization. How the cost function is used for optimizations? [8]

OR

Q8) Explain the need and working of the Gradient optimization method with example. [8]

Q9) Explain and illustrate the procedure of selecting a random sample. [8]

OR

Q10) What points should be taken into consideration by a researcher in developing a sample design for a research project? [8]

Q11) Explain the techniques of Dissemination of research findings and Reporting interpretation of results. [8]

OR

Q12) Explain the technique and importance of the oral presentation of research findings. Is only oral presentation sufficient? If not, Why? [8]



Total No. of Questions : 12]

SEAT No. :

PA-676

[Total No. of Pages : 2

[5928] - 122

M.E.(A.I&D.S /Computer Eng.)
DATA WAREHOUSING & MINING
(2017 Pattern) (Semester - II) (510308)

Time : 3 Hours]

[Max. Marks : 50

Instructions to the candidates :

- 1) *Answer Q.1 or Q.2, Q.3 or Q.4, Q.5 or Q.6, Q.7 or Q.8, Q.9 or Q.10, Q.11 or Q.12.*
- 2) *Neat diagrams must be drawn wherever necessary.*
- 3) *Figures to the right indicate full marks.*
- 4) *Assume suitable data if necessary.*
- 5) *Use of scientific calculator is permitted.*

Q1) Define Data Warehouse. List at least 6 characteristics or features of a Data Warehouse. Explain the various data sources of the data warehouse. [9]

OR

Q2) List the key challenges in the implementation of Data Warehouse. What type of processing take place in a data warehouse? Describe in detail. [9]

Q3) List the major areas in the data warehouse. Relate the architectural components to the major areas. Describe in detail. [9]

OR

Q4) Define metadata and its types. Explain in brief why metadata is essential for the end users and IT. [9]

Q5) Explain in brief dimensional modeling basics for data warehouse. Describe the STAR schema along with fact and component tables with suitable example. [8]

OR

P.T.O.

Q6) Give reasons. Why do you believe that ETL operations in a data warehouse environment are the most challenging? [8]

Q7) Explain in detail the stages in realization of the information potential with suitable diagram. [8]

OR

Q8) List the essential features necessary for user-information interface and Explain in brief OLAP implementation considerations. [8]

Q9) What is market basket analysis? Explain in brief with suitable example of mining frequent pattern. [8]

OR

Q10) Name the major phases of a data mining operations. Explain in brief the type of activities in them. [8]

Q11) List the major activities during data warehouse deployment. Describe the key task of any two activities in detail. [8]

OR

Q12) Describe any four different types of action for growth planning prompted by the statistics collected. [8]



Total No. of Questions : 12]

SEAT No. :

PA-677

[Total No. of Pages : 2

[5928]-123

M.E. (Computer Engineering) (Master of Data Science)

MACHINE LEARNING

(2017 Pattern) (Semester - II) (510309)

Time : 3 Hours]

[Max. Marks : 50

Instructions to the candidates:

- 1) *Answer Q.1 or Q.2, Q.3 or Q.4, Q.5 or Q.6, Q.7 or Q.8, Q.9 or Q.10, Q.11 or Q.12.*
- 2) *Neat diagrams must be drawn wherever necessary.*
- 3) *Use of logarithmic tables slide rule, Mollier charts, electronic pocket calculator and steam tables is allowed.*
- 4) *Figures to the right indicate full marks.*
- 5) *Assume suitable data, if necessary.*

Q1) a) What is classification? Explain Binary and multi-class classification with example. **[5]**

b) Differentiate between Generative and Discriminative Machine Learning Model. **[4]**

OR

Q2) a) Define Machine learning. Explain following types of machine learning with example. **[5]**

- i) Supervised learning
- ii) Unsupervised learning
- iii) Semi-supervised learning
- iv) Reinforcement learning

b) Explain grouping and grading models in detail. **[4]**

Q3) Explain bias and variance. What is the relationship between bias and variance? **[8]**

OR

Q4) Define factor analysis. State and explain different types of factor analysis. **[8]**

Q5) a) What is Regression? Explain simple and multivariate linear regression. **[4]**

b) Write and explain KNN algorithm. **[4]**

OR

Q6) a) Explain support vector machines as a linear and non-linear classifier in detail. **[4]**

b) Write and explain functioning of perceptron with suitable diagram of perceptron. **[4]**

P.T.O.

Q7) Consider the following transactions. [9]

Transaction	Items
T1	Bread, Jelly, Peanut Butter
T2	Bread, Peanut Butter
T3	Bread, Milk, Peanut Butter
T4	Beer, Bread
T5	Beer, Milk

Calculate the support and confidence for the following association rules

- a) Bread - > Peanut Butter
- b) Jelly - > Milk
- c) Beer - > Bread

OR

Q8) Construct decision tree for following example. [9]

Size	Color	Shape	Class
Medium	Magenta	Round	A
Large	Magenta	Round	A
Large	Blue	Round	A
Medium	Blue	Round	A
Medium	Black	Round	B
Large	Black	Cube	B
Large	Magenta	Cube	B
Large	Black	Round	B
Medium	Magenta	Cube	B

Q9) What is Naïve Bayes Classifier? Explain how it works with example. [8]

OR

Q10) Explain in detail Gaussian Mixtures and compression based models. [8]

Q11) Write a short note on : [8]

- a) Author profiling
- b) Diagnosis of crop disease

OR

Q12) Write a short note on : [8]

- a) Fraud detection
- b) Language identification



Total No. of Questions : 12]

SEAT No. :

PA-678

[Total No. of Pages : 2

[5928] - 124

M.E. (Computer Engineering) (Master of Data Science)

SOFT COMPUTING

(2017 Pattern) (Semester - II) (510310)

Time : 3 Hours]

[Max. Marks : 50

Instructions to the candidates :

- 1) *Answer Q.1 or Q.2, Q.3 or Q.4, Q.5 or Q.6, Q.7 or Q.8, Q.9 or Q.10, Q.11 or Q.12.*
- 2) *Neat diagrams must be drawn wherever necessary.*
- 3) *Figures to the right side indicate full marks.*
- 4) *Assume suitable data if necessary.*

- Q1)** a) What is soft computing? Explain the methods in soft computing. [5]
b) Differentiate between Hard and Soft Computing. [4]

OR

- Q2)** a) Explain the Fuzzy set operators, Union, Intersection, complement, cross product and max product composition with example. [5]
b) What is Fuzzy relation? Explain with example. [4]

- Q3)** a) What is defuzzification? Explain two methods of defuzzification. [5]
b) Explain Fuzzy 'if the else' rule. [4]

OR

- Q4)** a) Explain the components of Fuzzy inference systems. [5]
b) How fuzzy decision making is used in expert system? [4]

- Q5)** Explain the operators in Genetic algorithms with two examples each. [8]

OR

- Q6)** How genetic algorithm is applied in optimization problem? [8]

P.T.O.

Q7) What is artificial neural network? Explain the method of perception network architecture, training and testing. [8]

OR

Q8) How back propagation learning is carried out? Give with an example. [8]

Q9) What is associative memory network? Give the types of associative network with architecture. [8]

OR

Q10) How unsupervised learning is carried out with neural network? [8]

Q11) How hybrid systems are useful compared to single soft computing algorithm? [8]

OR

Q12) Explain the optimization of Travelling salesperson problem with Genetic algorithm. [8]



Total No. of Questions : 12]

SEAT No. :

PA-2904

[Total No. of Pages : 2

[5928]-125

M.E. (Computer Engineering) (Data Science)

DEEP LEARNING

(2017 Pattern) (610301) (Semester - III)

Time : 3 Hours]

[Max. Marks : 50

Instructions to the candidates :

- 1) *Attempt Q.1 or Q.2, Q.3 or Q.4, Q.5 or Q.6, Q.7 or Q.8, Q.9 or Q.10, Q.11 or Q.12.*
- 2) *Neat diagrams must be drawn wherever necessary.*
- 3) *Figures to the right indicates full marks.*
- 4) *Assume suitable data, if necessary and clearly state.*
- 5) *Use of cell phone is prohibited in the examination hall.*
- 6) *Use of electronic pocket calculator is allowed.*

Q1) Why We Need Backpropagation? Explain the algorithm in detail. State the advantages and disadvantages. **[9]**

OR

Q2) What is deep learning, explain its uses and application and history. **[9]**

Q3) What is PCA (Principle Component Analysis)? Explain the assumptions and limitations of PCA? Enlist the applications of PCA. **[9]**

OR

Q4) What is gradient decent. Explain following three variants of Gradient Descent: Batch, Stochastic and Mini batch. **[9]**

Q5) What is Dropout? How it solve problem of over fitting? Give the process of implementing dropout in deep neural networks. **[8]**

OR

Q6) a) Explain Early stopping? What criteria would you use for early stopping?**[5]**

b) What are Ensemble Methods? **[3]**

P.T.O.

Q7) Explain the different layers in CNN. Why do we use a Pooling Layer in a CNN? [8]

OR

Q8) How to apply guided backpropagation to enhance the interpretability of CNN. Justify with suitable example. [8]

Q9) Explain Generative Adversarial Network and Compare Variational Autoencoders and Generative Adversarial Network? [8]

OR

Q10) How to apply autoencoders for dimensionality reduction? Discuss the types of Autoencoders. [8]

Q11) Explain the architecture of an LSTM network. In what situations would you prefer to use LSTMs over simple Neural Nets? [8]

OR

Q12) Explain RNN and its application? What are the limitations of RNN? [8]



Total No. of Questions : 12]

SEAT No. :

PA-679

[Total No. of Pages : 2

[5928]-126

M.E. (Computer Engg./Data Science)

DATA MODELING AND VISUALIZATION

(2017 Pattern) (Semester - III) (610302)

Time : 3 Hours]

[Max. Marks : 50

Instructions to the candidates :

- 1) *All questions are compulsory.*
- 2) *Neat diagrams must be drawn wherever necessary.*
- 3) *Assume suitable data, if necessary.*
- 4) *Figures to the right indicate full marks.*

- Q1)** a) What are the advantages of visualization? [3]
b) Explain different data types like textual, nominal and ordinal data with examples. [5]

OR

- Q2)** a) Define Data Visualization and terms of definition. [4]
b) What are the four steps in working with data? Explain. [4]

- Q3)** a) How the histogram and scatter plots are useful in visualization of Numerical data? [4]
b) Explain the box plot used in understanding the data dispersion with the help of diagram. [4]

OR

- Q4)** a) How the streamlines are used in visualization of the Flow? [3]
b) Which parameters can be used to measure the Dispersion of Data? Give examples for any two. [5]

P.T.O.

Q5) How Tree maps and Heat maps are used for visualization of non numeric data? Explain with example. [8]

OR

Q6) Explain the node link diagram and shade maps with example. [8]

Q7) Explain different methods to deal with high dimensional data? [9]

OR

Q8) Explain the steps of Principle Component Analysis PCA with example. [9]

Q9) Explain the Gestalt laws of Proximity and similarity with example. [9]

OR

Q10) Explain the Gestalt laws of connectedness and Continuity with example. [9]

Q11) Explain the different features of Tableau used in visualization. [8]

OR

Q12) How to evaluate a good visualization. Justify your answer. [8]



Total No. of Questions : 12]

SEAT No. :

PA-680

[Total No. of Pages : 2

[5928]-127
M.E. (Cyber Security)
MATHEMATICAL FOUNDATIONS FOR CYBER
SECURITY
(2017 Pattern) (510401) (Semester - I)

Time : 3 Hours]

[Max. Marks : 50

Instructions to the candidates :

- 1) *Solve Q.1 or Q.2, Q.3 or Q.4, Q.5 or Q.6, Q.7 or Q.8, Q.9 or Q.10, Q.11 or Q.12.*
- 2) *Neat diagrams must be drawn whenever necessary.*
- 3) *Figures to the right indicate full marks.*
- 4) *Assume suitable data if necessary.*

Q1) What are different binary operations? Explain with suitable examples. [8]

OR

Q2) Give linear congruence equations for the solutions of 8 Queens problems. [8]

Q3) Define groups? What do you mean by cyclic groups, cosets? Explain with suitable examples. [8]

OR

Q4) Discuss lattice as algebraic system. [8]

Q5) What is relative prime? How to check primeness of number. [8]

OR

Q6) Explain Euler's Theorem. Give the general formula for computing $\phi(n)$. [8]

Q7) What are various factorization methods? Explain any one with suitable examples. [8]

OR

Q8) Discuss quadratic congruence modulo a prime with example. [8]

P.T.O.

Q9) Explain conditional probability with examples. [9]

OR

Q10) Explain Markov-chain model in detail. [9]

Q11) Write a short note on - [9]

- a) Equivalence of codes.
- b) Linear codes.

OR

Q12) Write a short note on - [9]

- a) Hamming codes.
- b) Hadamard code.



Total No. of Questions : 7]

SEAT No. :

PA-681

[Total No. of Pages : 1

[5928]-128

M.E. (Cyber Security)

MODERN CRYPTOGRAPHY

(2017 Pattern) (Semester - I) (510402)

Time : 3 Hours]

[Max. Marks : 50

Instructions to the candidates :

- 1) Q. No. 7 is compulsory, solve any five from Q. No. 1 to Q. No. 6.
- 2) Figures to the right indicate full marks.
- 3) Neat diagrams must be drawn wherever necessary.
- 4) Assume suitable data, if necessary.

Q1) What is perfect security? Describe semantic security, its connection with weaker security notions and consequences? [8]

Q2) Differentiate between stream ciphers and block ciphers. Discuss any four modes of operation of block ciphers. [8]

Q3) Define non-singular elliptic curves suitable for use in cryptography. Consider an elliptic curve $E_{13}(1, 1)$. Compute the result of addition of the points $P(0, 1)$ and $Q(0, 1)$ on the given curve. [8]

Q4) Describe digital certificates. How digital signatures are different from digital certificates? Explain the components of digital signature. [8]

Q5) Comment on "Cyber Security Laws and Regulations - current status in India". [8]

Q6) Write short note on : [8]
a) Steganography
b) Digital Signatures

Q7) Elaborate security policy objectives and security metrics. Discuss cyber security management in detail. [10]



Total No. of Questions : 8]

SEAT No. :

PA-3185

[Total No. of Pages : 2

[5928]-129

M.E. (Computer Engineering)

CYBER SECURITY

**Secure Software Design, Coding Practices and Ethics
(2017 Pattern) (Semester - I) (510403)**

Time : 3 Hours]

[Max. Marks : 50

Instructions to the candidates:

- 1) *Attempt Q.1 or Q.2, Q.3 or Q.4, Q.5 or Q.6, Q.7 or Q.8.*
- 2) *Figure to the right side indicates full marks.*
- 3) *Neat diagrams must be drawn wherever necessary.*
- 4) *Assume suitable data, if necessary.*

Q1) a) Explain the principles of software engineering ethics. **[5]**

b) Explain the objective of software security. **[4]**

OR

Q2) a) Why is security a software issue? **[5]**

b) Explain the principles of software assurance. **[4]**

Q3) a) Discuss the most common requirements Elicitation Techniques. **[5]**

b) What elicitation techniques can be used with SQUARE? **[4]**

OR

Q4) a) What are the common approaches followed for developing high-level and detailed requirements using SQUARE? **[5]**

b) Explain architecture risk management, with example. **[4]**

Q5) a) Explain OWASP Software assurance maturity model. **[8]**

b) What is the secure software development life cycle (SDLC)? **[8]**

OR

P.T.O.

- Q6)** a) What are secure coding principles? [8]
b) Explain security breach. What are the three main causes of security breaches? [8]

- Q7)** a) What is penetration testing software? What are the 5 stages of penetration testing? [8]
b) Explain the any four main methodologies of threat modelling? [8]

OR

- Q8)** a) Describe the common methods for managing vulnerabilities. How do you manage vulnerability management? [8]
b) Explain risk-based testing strategy with different approaches in cyber security? [8]



Total No. of Questions : 12]

SEAT No. :

PA-590

[Total No. of Pages : 2

[5928]-13

M.E. (Civil) (Environmental Engineering)

ENVIRONMENTAL SANITATION

(2017 Pattern) (Semester - I) (501064)

Time : 3 Hours]

[Max. Marks : 50

Instructions to the candidates :

- 1) *Solve Q1 or Q2, Q3 or Q4, Q5 or Q6, Q7 or Q8, Q9 or Q10, Q11 or Q12.*
- 2) *Figures to the right indicate full marks.*
- 3) *Your answers will be valued as a whole.*
- 4) *Assume suitable data, if necessary.*

Q1) Discuss the role of Micro-organisms in communicable diseases. [5]

OR

Q2) How diseases communicated by discharges of intestines? Discuss. [5]

Q3) Give short note on with an example [5]

- a) Control of Insects
- b) Control of Rodent

OR

Q4) Discuss in details any two fly control methods. [5]

Q5) How study of factors required in industrial Sanitation? [5]

OR

Q6) What is industrial poisons? Discuss. [5]

Q7) How population habits and environmental conditions affect the rural sanitation? [5]

OR

Q8) Discuss the rural sanitation improvement schemes. (Any Two) [5]

P.T.O.

- Q9)** a) How one-pipe system and two pipe system are differ to each other? Discuss. [7]
b) Discuss the factors affecting the design of water supply in buildings. [7]

OR

- Q10)** a) What is Break pressure tank system and hydro-pneumatic system? Discuss. [7]
b) Discuss the steps involved in design of water pipes. [7]

- Q11)** a) Discuss with suitable sketches about Gully Traps and Intercepting Traps. [8]
b) Discuss about- Flushing Cistern, Wash Basin, Lavatory Basin and Sink. [8]

OR

- Q12)** a) What are the principles governing design of building drainage? Discuss in detail. [8]
b) What is drainage design of high rise buildings? Discuss in details. [8]



Total No. of Questions : 8]

SEAT No. :

PA-682

[Total No. of Pages : 1

[5928]-136

M.E. (Electrical) (Control Systems)

OPTIMIZATION TECHNIQUES IN CONTROL SYSTEM

(2017 Pattern) (503101) (Semester - I)

Time : 3 Hours]

[Max. Marks : 50

Instructions to the candidates :

- 1) Answer Q.1 or Q.2, Q.3 or Q.4, Q.5 or Q.6, Q.7 or Q.8.
- 2) Figures to the right indicate full marks.
- 3) Neat diagrams must be drawn wherever necessary.
- 4) Use of algorithmic tables slide rule, Mollier charts and electronic pocket calculator and steam table is allowed.
- 5) Assume suitable data if necessary.

- Q1) a) Explain what you understand by relative and global maxima and minima.[5]
b) Explain what you mean by unimodal function. [4]

OR

- Q2) Find the Maxima and Minima if any of the function $F(X) = 8x^3 - 12x^2 + 20x - 4$. [9]

- Q3) Use Lagrange multiplier approach to minimize the function $F(X) = 2X_1^2 + X_2^2 + 3X_3^2 + 10X_1 + 8X_2 + 6X_3 - 100$ subjected to $g(x) = X_1 + X_2 + X_3 = 20$
 $X_1, X_2, X_3 \geq 0$. [9]

OR

- Q4) What do you understand by optimization and write the necessary condition for relative minimum of function of single variable. [9]

- Q5) Explain the method of conversion of non-serial system to serial system problem. [16]

OR

- Q6) Explain concept of sub optimization and principle of optimality. [16]

- Q7) Explain Stochastic Linear Programming. [16]

OR

- Q8) a) Conversion of a Zero-One Polynomial Programming Problem into a Zero-One LP Problem. [8]
b) Explain the integer nonlinear programming. [8]



Total No. of Questions : 6]

SEAT No. :

PA-683

[Total No. of Pages : 1

[5928]-137

M.E. (Electrical) (Control Systems)
AUTOMATION IN MANUFACTURING
(2017 Pattern) (503102) (Semester - I)

Time : 3 Hours]

[Max. Marks : 50

Instructions to the candidates :

- 1) Answer questions fromn Q.1 or Q.2, Q.3 or Q.4, Q.5 or Q.6.
- 2) Figures to the right indicates full marks.
- 3) Neat diagrams must be drawn wherever necessary.

- Q1)** a) State different types of transducers for displacement measurement. [5]
b) Explain importance of PID controller with Block diagram. [5]
c) Explain any one type of stepper motor. [4]
d) What is cyber Physical System and explain its features. [4]

OR

- Q2)** a) Explain following static characteristics related to sensors [4]
i) Static error ii) Precision
iii) Threshold iv) Resolution
b) Write short note on linear motion bearings with diagrams. [5]
c) Explain with diagram complete working of Hydraulic actuating systems. [5]
d) Explain architecture of Cyber Physical system. [4]

- Q3)** a) What are the advantages of Digital Manufacturing? [8]
b) Explain important features of Digital Manufacturing. [8]

OR

- Q4)** a) Explain different methods of Digital manufacturing science? Explain any one. [8]
b) Explain Operation Reference Mode of Digital Manufacturing. [8]

- Q5)** a) Explain End to end Digital integration within smart factory. [8]
b) Explain characteristics of Industry 4.0. [8]

OR

- Q6)** a) List out the drivers of Industry 4.0. Explain in detail. [8]
b) Explain the benefits of Industry 4.0. [8]



Total No. of Questions : 5]

SEAT No. :

PA-684

[Total No. of Pages : 2

[5928]-138

M.E. (Electrical) (Control Systems)
NON LINEAR CONTROL SYSTEM
(2017 Pattern) (Semester - I) (503103)

Time : 3 Hours]

[Max. Marks : 50

Instructions to the candidates :

- 1) *Figures to the right indicate full marks.*
- 2) *Neat diagrams must be drawn wherever necessary.*
- 3) *Use of algorithmic tables slide rule, Mollier charts and electronic pocket calculator and steam table is allowed.*
- 4) *Assume suitable data, if necessary.*
- 5) *Q.5 is compulsory.*

- Q1) a)** Explain following terms **[6]**
- i) Positive definite
 - ii) Positive Semi-definite
 - iii) Negative definite
- b) Explain physical non-linearity's observed in physical control system. **[6]**
- c) Explain Liapunov stability criterion. **[6]**

OR

- Q2) a)** Express Scalar function given below in Quadratic form & test it for definiteness
- $$V(x) = 8x_1^2 + x_2^2 + 4x_3^2 + 2x_1x_2 - 4x_1x_3 - 2x_2x_3 .$$
- [6]**
- b) Explain delta method of constructing a phase plane trajectory. **[6]**
- c) Explain Popov criterion for absolute stability. **[6]**

- Q3) a)** Write short note on notion of sliding mode control. **[6]**
- b) Write a short note on Input State Linearization. **[5]**
- c) Write a short note on Chattering as used in Sliding Control. **[5]**

OR

P.T.O.

Q4) Explain the following (any two) : **[16]**

- a) Concept of Variable Structure Control
- b) Properties of Sliding Mode Control
- c) Effect of disturbance on Sliding Mode Control

Q5) Explain any two of the following : **[16]**

- a) Explain any non-linear system design using sliding mode technique.
- b) Effect of disturbance on Sliding Mode Control.
- c) Matched & Unmatched uncertainty in case of Sliding Mode Control.



Total No. of Questions : 4]

SEAT No. :

PA-685

[Total No. of Pages : 2

[5928]-139

M.E. (Electrical) (Control System)

RESEARCH METHODOLOGY

(2017 Pattern) (Semester - I) (503104)

Time : 3 Hours]

[Max. Marks : 50

Instructions to the candidates:

- 1) All questions are compulsory.
- 2) Figures to the right indicate full marks.
- 3) Neat diagrams must be drawn wherever necessary.
- 4) Use of logarithmic tables slide rule, Mollier charts, electronic pocket calculator and steam tables is allowed.
- 5) Assume suitable data, if necessary.

- Q1) a) Describe different types of research. [5]
b) What are different steps involved in report writing of project. [7]
c) Explain the standard writing format for research schemes of AICTE and DST. [6]

OR

- Q2) a) Explain about research proposal. Elaborate about literature survey in writing research proposal. [7]
b) Explain with illustration properties of fields and vectors. [5]

- c) Let $A = \begin{bmatrix} 2 & -2 & 2 & 1 \\ -3 & 6 & 0 & -1 \\ 1 & -7 & 10 & 2 \end{bmatrix}$ reduce A to echelon form using pivoting method. [6]

Q3) Solve any two

- a) $v = (3, y, -4)$ is linear combination of vectors $U_1 = (1,2,3)$, $U_2 = (2,3,y)$
 $U_3 = (3,5,6)$ Find scalar x,y,z for linear combination. [8]
- b) Write short notes on homogeneous and non homogeneous systems. [8]
- c) Explain Gassian elimination method for solving linear equation. [8]

P.T.O.

Q4) Solve any two

- a) For a given system find eigen values, eigen vectors and Diagonal Matrix

$$A = \begin{bmatrix} 1 & 2 & 3 \\ 1 & 1 & 4 \\ 2 & 1 & 0 \end{bmatrix} \quad [8]$$

- b) Write software program for finding eigen values & eigen vectors if system matrix A is given. [8]
- c) Write short note on Diagonal form and Jordan form of matrix representation. [8]



Total No. of Questions : 12]

SEAT No. :

PA-1146

[Total No. of Pages : 2

[5928]-14

M.E. (Civil - Environmental Engineering)
INDUSTRIAL WASTE WATER TREATMENT AND
MANAGEMENT
(2017 Pattern) (Semester - II)

Time : 3 Hours]

[Max. Marks : 50

Instructions to the candidates :

- 1) *Solve Q1 or Q2, Q3 or Q4, Q5 or Q6, Q7 or Q8, Q9 or Q10, Q11 or Q12.*
- 2) *Figures to the right indicate full marks.*
- 3) *Your answers will be valued as a whole.*
- 4) *Assume suitable data, if necessary.*
- 5) *Use of electronic pocket calculator and steam table is allowed.*

Q1) Discuss the Prevention and Control of Industrial Pollution. **[5]**

OR

Q2) What are different Source reduction techniques? **[5]**

Q3) Explain how the Air Stripping Process works. **[5]**

OR

Q4) What is the application of Chemical oxidation process? Enlist the commonly use oxidants. **[5]**

Q5) Suggest and comment on the treatment & disposal method of effluent from steel manufacturing industry. **[5]**

OR

Q6) Discuss the manufacturing process and sources of effluents for paper and pulp industry. **[5]**

P.T.O.

Q7) What are the sources and characteristics of effluent from Petroleum industry? [5]

OR

Q8) Suggest and comment on the treatment & disposal method of effluent from Atomic Energy Plant. [5]

Q9) a) With suitable sketch discuss the features of Common Effluent Treatment Plants? [7]

b) What is the significance of Zero effluent discharge system? Discuss with example. [7]

OR

Q10)a) What are the points to be considered during planning of CETP? Discuss any one in details. [7]

b) How industries plays important role in wastewater reuse? Comment with suitable example. [7]

Q11)a) How polymer coagulation is differ than other methods of coagulations? Enlist the demerits of this method? [8]

b) Enlist the major components of wastewater treatment plant for Pharmaceutical industry? Discuss its suitability. [8]

OR

Q12)a) Why the effluent from Dye stuff and dye manufacturing industries are more harmful. Discuss with suitable example. [8]

b) Explain adsorption phenomena for industrial wastewater treatment. [8]



Total No. of Questions : 6]

SEAT No. :

PA-686

[Total No. of Pages : 2

[5928] - 140

M.E. (Electrical Engineering) (Control Systems)
MULTIVARIABLE AND OPTIMAL CONTROL SYSTEM
(2017 Pattern) (Semester - II) (503107)

Time : 3 Hours]

[Max. Marks : 50

Instructions to the candidates :

- 1) *Answer Q.1 or Q.2, Q.3 or Q.4, Q.5 or Q.6.*
- 2) *Figures to the right side indicate full marks.*
- 3) *Neat diagrams must be drawn wherever necessary.*
- 4) *Use of algorithmic tables slide rule, Mollier charts and electronic pocket calculator and steam table is allowed.*
- 5) *Assume suitable data if necessary.*

- Q1)** a) Discuss the merits and demerits of representing the multivariable control system into [5]
- i) Differential operator form.
 - ii) Transfer matrix form.
 - iii) State space form.
- b) State the condition for controllability and observability of multivariable control system. [4]
- c) What is the observer? Explain the neat block diagram of state estimation problem using observer. [5]
- d) Discuss the formulation of an optimal control problem using quadratic performance criterion. [4]

OR

- Q2)** a) Outline the procedure for obtaining the optimal control law for time invariant state regulator problem. [5]
- b) Explain in decoupling or non-interactive control for multivariable control system design. [4]
- c) Elaborate sliding mode observer and give it's robustness properties. [4]
- d) Explain with block diagram pole allocation using Linear state variable feedback in multivariable control system. [5]

P.T.O.

Q3) a) Explain the Bang-Bang control strategy and state the merits of Bang-Bang controller. [8]

b) Discuss step by step procedure of solving optimal control problem using Pontryagin's minimum principle. [8]

OR

Q4) a) Explain the optimal control theory. [10]

b) Define Hamiltonian. Derive state, Co-state and control equations. [6]

Q5) a) Define and explain the singular control solutions. [8]

b) Explain in details the applications of optimal control in discrete and continuous systems. [8]

OR

Q6) a) Explain in details Numerical solution of matrix Riccati equation. [8]

b) State and explain comparison between sliding mode observer and nonlinear Extended state observer (Nonlinear ESO). [8]



Total No. of Questions : 6]

SEAT No. :

PA-687

[Total No. of Pages : 1

[5928]-141

M.E. (Electrical) (Control Systems)
CONTROL OF POWER ELECTRONIC CIRCUITS
(2017 Credit Pattern) (Semester - II) (503108)

Time : 3 Hours]

[Max. Marks : 50

Instructions to the candidates:

- 1) *Answer Q1 or Q2, Q3 or Q4, Q5 or Q6.*
- 2) *Figures to the right indicate full marks.*
- 3) *Neat diagrams must be drawn wherever necessary.*
- 4) *Use of algorithmic tables slide rule, Mollier charts, and electronic pocket Calculator and steam table is allowed.*
- 5) *Assume suitable data, if necessary.*

- Q1)** a) Explain the roles & objectives of power electronic converters. [6]
b) Write brief a note on Sampled data type model, averaged models, large-signal and small-signal models, behavioural models. [12]

OR

- Q2)** a) Explain in brief Control families of Power Electronic Converters. [12]
b) Explain relations between modelling and control of power electronic converters. [6]

- Q3)** a) Draw the circuit diagram of Buck-Boost Converter & explain circuit topologies of it. [12]
b) Write a note on switched type model. [4]

OR

- Q4)** a) Explain pole placement based on observer design for linear feedback control. [8]
b) Discuss the example of Grid connected single phase DC-AC converter. [8]

- Q5)** a) Explain variable structure control of power electronic converters. [8]
b) Draw neat diagram of three phase voltage source grid connected inverter connected with associated d-q frame control structure and Explain system modelling steps. [8]

OR

- Q6)** Explain variable structure control design with one application as DC-DC power stage. [16]



Total No. of Questions : 8]

SEAT No. :

PA-1148

[Total No. of Pages : 2

[5928]-142

M.E. (Electrical-Control System)

DIGITAL SIGNAL PROCESSING AND ITS APPLICATIONS

(2017 Pattern) (503109) (Semester - II)

Time : 3 Hours]

[Max. Marks : 50

Instructions to the candidates :

- 1) Solve Q.1 or Q.2, Q.3 or Q.4, Q.5 or Q.6, Q.7 or Q.8.
- 2) Neat diagrams must be drawn wherever necessary.
- 3) Figures to the right indicates full marks.
- 4) Use of calculator is allowed.
- 5) Assume suitable data if necessary.

Q1) a) Describe elementary discrete time signals. [5]

Explain :

- i) Energy and power signals
 - ii) Symmetric (even) and Anti-symmetrical (odd) signals
- b) For two-sided z-transform state and prove following properties : [4]
- i) Linearity property
 - ii) Convolution property

OR

Q2) a) Determine inverse z - transform of $X(z) = \frac{1}{(1+z^{-1})(1-z^{-1})^2}$. [5]

b) Explain the Sampling of continuous time signals. [4]

Q3) a) Define Discrete Time Fourier Transform (DTFT) of sequence $x(n)$. Explain the following properties of DFT. [5]

- i) Linearity property
 - ii) Time shifting property
 - iii) Frequency shifting property
 - iv) Time reversal property
- b) What is the need of FFT algorithm? Explain DIT FFT algorithm. [4]

P.T.O.

OR

- Q4)** a) Explain the Impulse Invariant technique for the design of HR filter and obtain the mapping formula for the Impulse Invariant transformation. [5]
b) Describe Butterworth filters. Comment on the pass band and stop band characteristics also. [4]

- Q5)** a) Explain the procedure for designing FIR filter using the Kaiser window. In what way is it superior to other window functions? [10]
b) Obtain Direct form and Cascade form realizations for the transfer function of an FIR system given by : [6]

$$H(z) = \left(1 - \frac{1}{4}z^{-1} + \frac{3}{8}z^{-2}\right) \left(1 - \frac{1}{8}z^{-1} - \frac{1}{2}z^{-2}\right)$$

OR

- Q6)** a) Write the standard mathematical equation of the Direct form and Cascade form realizations of an FIR system and explain realization structure in detail. [6]
b) A low pass filter is to be designed with the following desired frequency response : [10]

$$H_d(e^{j\omega}) = \begin{cases} 0 & -\pi/4 \leq \omega \leq \pi/4 \\ e^{-j2\omega} & \pi/4 \leq \omega \leq \pi \end{cases}$$

Determine the filter coefficients $h_d(n)$, if the window function is defined as

$$w(n) = \begin{cases} 1 & 0 \leq n \leq 4 \\ 0 & \text{otherwise} \end{cases}$$

Also, determine the frequency response $H(e^{j\omega})$ of the designed filter.

- Q7)** a) Discuss the various methods of speed control of electrical machines by the concepts of digital signal processing (DSP). [8]
b) Explain various methods of measurement of power by DSP. [8]

OR

- Q8)** a) Discuss PWM generation by DSP. [8]
b) Discuss frequency measurement by DSP. [8]



Total No. of Questions : 6]

SEAT No. :

PA-688

[Total No. of Pages : 2

[5928]-143

**M.E. (Electrical Engineering) (Control System)
ADVANCED DRIVES AND CONTROL
(2017 Credit Pattern) (Semester - III) (603101)**

Time : 3 Hours]

[Max. Marks : 50

Instructions to the candidates:

- 1) *Answer Q.1 or Q.2, Q.3 or Q.4, Q.5 or Q.6.*
- 2) *Figures to the right side indicate full marks.*
- 3) *Assume suitable data, if necessary.*

- Q1)** a) State and explain the factors affecting the time and energy during starting of electric drive System. [4]
- b) Explain static krammer control drive of induction motor. [5]
- c) Draw a neat diagram of the system model and derive the transfer function of the converter fed DC motor. [5]
- d) Write a note on PWM inverters. [4]

OR

- Q2)** a) Explain criteria for selection of drive components. [4]
- b) Compare the performance of converter fed DC motor with chopper fed DC motor. [5]
- c) Explain the effect of space harmonics and pulsating torques developed in the inverter fed three phase induction motor. [5]
- d) Explain sensorless vector control of induction motor. [4]
- Q3)** a) With reference to synchronous motor drives explain following. [16]
- i) D-q axis equivalent circuit.
 - ii) Flux weakening operation-the control strategy.

OR

P.T.O.

Q4) Explain the following in detail:

- a) Switched Reluctance Motor. [8]
- b) Sinusoidal SPM drive. [8]

- Q5)**
- a) Explain the industrial application of PID controller. [8]
 - b) Explain design procedure of current control in closed loop control of electric drive. [8]

OR

- Q6)**
- a) Explain micro computer control of electric drive. [8]
 - b) Explain phase locked loop in closed loop control of electric drive. [8]

***** END *****

Total No. of Questions : 6]

SEAT No. :

PA-689

[Total No. of Pages : 2

[5928]-144

M.E. (Electrical) (Control Systems)
SYSTEM IDENTIFICATION AND ADAPTIVE CONTROL
(2017 Pattern) (Semester - III) (603102)

Time : 3 Hours]

[Max. Marks : 50

Instructions to the candidates:

- 1) *Answer Q1 or Q2, Q3 or Q4, Q5 and Q6 are compulsory.*
- 2) *Figures to the right side indicate full marks.*
- 3) *Neat diagrams must be drawn wherever necessary.*
- 4) *Use of algorithmic tables slide rule, Mollier charts, and electronic pocket calculator and steam table is allowed.*
- 5) *Assume suitable data, if necessary.*

- Q1) a)** With the help of neat diagram explain the process of system identification. **[5]**
- b) Derive least square estimate of θ for model given by $y = \phi\theta$. **[4]**

OR

- Q2) a)** Compute the QR factorization of matrix : $\begin{bmatrix} 12 & 27 \\ 4 & 2 \\ 6 & 10 \end{bmatrix}$ **[5]**

- b) Explain the parametric and non-parametric methods of system identification. **[4]**

- Q3) a)** With the help of block diagram explain 'self tuning regulator'. **[5]**
- b) Prove the matrix inversion lemma: $[A + BCD]^{-1} =$ **[4]**

$$A^{-1} - A^{-1}B[C^{-1} + DA^{-1}B]^{-1}DA^{-1}$$

$$[A + BCD]^{-1} = [A + BCD] \left\{ A^{-1} - A^{-1}B[C^{-1} + DA^{-1}B]^{-1}DA^{-1} \right\} I = I$$

OR

P.T.O.

Q4) Write short notes on any three: [9]

- a) Recursive estimation
- b) Instrumental variable method
- c) Model structure
- d) Maximum likelihood method
- e) Bayesian learning
- f) Pattern recognition

Q5) a) Explain pole placement design and derive the Diophantine equation. [8]

b) What do you understand by persistently existing signal? [8]

What is the order of following signals:

- i) white noise
- ii) step signal
- iii) sum of sinusoids

Q6) With the help of both MIT rule and Lyapunov theory, design an MRAS for system described by $G(s) = \frac{b}{s+a}$ where a and b are unknown. The controller

is given by $u(t) = \theta_1 u_c(t) + \theta_2 y(t)$ and the desired closed loop model is

$\frac{dy_m}{dx} = -a_m y_m + b_m u_c$. Draw simulation diagram and compare two methods. Assume

$$V(\theta) = \frac{1}{2} \left[e^2 + \frac{1}{by} (b\theta_2 + a - a_m)^2 + \frac{1}{by} (b\theta_1 - b_m)^2 \right] \quad [16]$$



Total No. of Questions : 4]

SEAT No. :

PA-690

[Total No. of Pages : 3

[5928]-145

M.E. (Electrical) (Power Electronics and Drives)

LINEAR SYSTEMS THEORY AND DESIGN

(2017 Pattern) (Semester - I) (503301)

Time : 3 Hours]

[Max. Marks : 50

Instructions to the candidates:

- 1) Neat diagrams must be drawn wherever necessary.
- 2) Figures to the right indicate full marks.
- 3) Assume suitable data if necessary.
- 4) Use of electronic calculator is allowed.

Q1) a) Check whether the following vectors are linearly dependent or independent. [4]

i) $\bar{a} = (1,1,1)$ $\bar{b} = (1,2,0)$ $\bar{c} = (0,-1,1)$

ii) $\bar{a} = (1,0,0)$ $\bar{b} = (0,1,0)$ $\bar{c} = (0,0,1)$

b) Consider the vectors $a = 3i + 8j + k$ and $b = 6i + 8j + 2k$. [5]

i) Deduce the direction cosine of \bar{A} and \bar{B}

ii) Deduce direction of cosine of \overline{AB}

Q2) a) For the following matrices [4]

$$A = \begin{vmatrix} 4 & 1 \\ 3 & 2 \end{vmatrix} \quad B = \begin{vmatrix} 1/3 & -2/3 & 2/3 \\ 2/3 & 2/3 & 1/3 \\ -2/3 & 1/3 & 2/3 \end{vmatrix}$$

Perform:

- i) Orthogonality
- ii) Symmetry
- iii) Skew symmetry

OR

P.T.O.

- b) Explain, with examples, the following characteristics of square matrices:[4]
- Symmetric
 - Skew-symmetric
 - Diagonal
 - Unit
- c) Find mean, standard deviation for the following data: [5]

Class	0-10	10-20	20-30	30-40	40-50	50-60	60-70	70-80
Frequency	5	10	20	40	30	20	10	5

- Q3) a) The actual volume of liquid in 500 ml jar follows a normal distribution with mean 500 ml and variance 16 ml. If X denotes the actual volume liquid in a jar, find what is: [8]
- $P(X > 496)$
 - $P(X < 498)$
 - $P(492 > X < 512)$

Z Score value table

z	.00	.01	.02	.03	.04	.05	.06	.07	.08	.09
-2.0	.0228	.0222	.0217	.0212	.0207	.0202	.0197	.0192	.0188	.0183
-1.9	.0287	.0281	.0274	.0268	.0262	.0256	.0250	.0244	.0239	.0233
-1.8	.0359	.0351	.0344	.0336	.0329	.0322	.0314	.0307	.0301	.0294
-1.7	.0446	.0436	.0427	.0418	.0409	.0401	.0392	.0384	.0375	.0367
-1.6	.0548	.0537	.0526	.0516	.0505	.0495	.0485	.0475	.0465	.0455
-1.5	.0668	.0655	.0643	.0630	.0618	.0606	.0594	.0582	.0571	.0559
-1.4	.0808	.0793	.0778	.0764	.0749	.0735	.0721	.0708	.0694	.0681
-1.3	.0968	.0951	.0934	.0918	.0901	.0885	.0869	.0853	.0838	.0823
-1.2	.1151	.1131	.1112	.1093	.1075	.1056	.1038	.1020	.1003	.0985
-1.1	.1357	.1335	.1314	.1292	.1271	.1251	.1230	.1210	.1190	.1170
-1.0	.1587	.1562	.1539	.1515	.1492	.1469	.1446	.1423	.1401	.1379

z	.00	.01	.02	.03	.04	.05	.06	.07	.08	.09
1.4	.9192	.9207	.9222	.9236	.9251	.9265	.9279	.9292	.9306	.9319
1.5	.9332	.9345	.9357	.9370	.9382	.9394	.9406	.9418	.9429	.9441
1.6	.9452	.9463	.9474	.9484	.9495	.9505	.9515	.9525	.9535	.9545
1.7	.9554	.9564	.9573	.9582	.9591	.9599	.9608	.9616	.9625	.9633
1.8	.9641	.9649	.9656	.9664	.9671	.9678	.9686	.9693	.9699	.9706
1.9	.9713	.9719	.9726	.9732	.9738	.9744	.9750	.9756	.9761	.9767
2.0	.9772	.9778	.9783	.9788	.9793	.9798	.9803	.9808	.9812	.9817

b) Explain in detail central limit theorem. [8]

OR

b) Explain test of significance with example. [8]

Q4) a) In air cooled engine cylinder simulation study, a circular cooling fin was heated in the central region & placed in the air stream. Ten thermocouples were placed at equal distance radially on the fin for temperature measurement. Following data was obtained: [8]

Radius r (cm)	2	4	6	8	10	12	14	16	18	20
Temp T (deg C)	75.5	73.1	70.5	67.7	64.2	62.1	59.4	57.2	54.8	52.2

Determine the coefficient for the curve of the form $T = C_0 + C_1R$ by:

- i) Method of sequential differences
 - ii) Method of Extended differences
- b) Explain method of sequential differences and method of least square for graphical data representation and parameter determination. [8]



Total No. of Questions : 8]

SEAT No. :

PA-691

[Total No. of Pages : 2

[5928]-146

M.E. (Electrical) (Power Electronics & Drives)
MODELLING AND ANALYSIS OF ELECTRICAL MACHINES
(2017 Pattern) (Semester - I) (503302)

Time : 3 Hours]

[Max. Marks : 50

Instructions to the candidates:

- 1) *Figures to the right indicate full marks.*
- 2) *Assume suitable data, if necessary.*

Q1) a) Draw necessary diagrams to explain the common essential features of rotating electrical machine. **[5]**

b) With necessary sketches, explain Kron's primitive machine. How are the various windings of a machine represented by the primitive machine. **[5]**

OR

Q2) a) Derive the transformations for currents between two-phase (α, β) rotating balanced winding and pseudo-stationary two-phase ($d-q$) winding. **[6]**

b) Explain what is meant by 'power invariance' in transformation theory applied to Electrical machines. **[4]**

Q3) a) Discuss the mathematical model of DC series motor. **[5]**

b) Derive the mathematical model of DC shunt motor. **[5]**

OR

Q4) a) Discuss the Principle of Vector control. **[4]**

b) Write two axis ($d-q$) Voltage equation matrix model in various reference frame. **[6]**

P.T.O.

Q5) a) Derive expressions for armature mutual inductance of salient pole synchronous machine from a consideration of its basic Parameters. [7]

b) A 3-phase 50 Hz cylindrical-rotor synchronous machine has the following parameters: [8]

Self-inductance for phase a = 3.15 mH

Armature leakage inductance = 0.35 mH

For this machine calculate the mutual inductance between armature phases and its Synchronous reactance.

OR

Q6) a) Starting from the impedance matrix of a 3-phase salient pole synchronous machine fitted with amortisseurs, obtain an expression for the instantaneous electromagnetic torque and explain the significance of the various terms in it. [8]

b) From the torque matrix of a 3-phase salient pole alternator and its phasor diagram, derive an expression for synchronous power in terms of load angle. [7]

Q7) a) Explain Linearization of machine equations. [8]

b) Discuss Performance prediction of Induction machine with stator electric transients neglected. [7]

OR

Q8) Write short notes on:

a) Small displacement stability: Eigen values, Eigen values of typical induction machine. [8]

b) Small displacement stability: Eigen values, Eigen values of typical synchronous machine. [7]



Total No. of Questions : 6]

SEAT No. :

PA-692

[Total No. of Pages : 2

[5928]-147

M.E. (Electrical) (Power Electronics & Drives)

POWER CONVERTERS - I

(2017 Pattern) (Semester - I) (503303)

Time : 3 Hours]

[Max. Marks : 50

Instructions to the candidates:

- 1) *Attempt Q1 or Q2, Q3 or Q4, Q5 or Q6.*
- 2) *Figures to the right indicate full marks.*
- 3) *Use of electronic calculator is allowed.*
- 4) *Assume suitable data, if necessary.*

Q1) a) Explain the working details and characteristics of IGBT. **[8]**

b) Explain with necessary diagrams and waveforms, the operation of a three phase full converter. Derive the equation for output voltage. **[10]**

OR

Q2) a) Explain the operation of Boost converter with necessary waveforms. **[8]**

b) Explain six step voltage source inverter (120 deg mode) with necessary waveforms and derive line-line output voltage equation using Fourier series. **[10]**

Q3) a) Explain single phase bi directional controller with R load. **[6]**

b) A single phase voltage controller is employed for controlling the power flow from 230 V 50 Hz into a load circuit containing $R = 4\Omega$ and $\omega L = 3\Omega$. Calculate: **[10]**

i) The control range of firing angle.

ii) Maximum value of RMS load current maximum power and power factor.

OR

P.T.O.

Q4) a) What are the steps involved in determining the output voltage waveforms of 3 phase bidirectional controllers? [10]

b) What are the advantages and disadvantages of bidirectional control. [6]

Q5) a) What is Cycloconverter? Explain the operation of three phase Cycloconverter with necessary diagram and waveforms. [10]

b) What are the advantages and disadvantages of Cyclo converters? [6]

OR

Q6) a) Draw the circuit diagram and explain the principle of operation of a 1 phase bridge type Cycloconverter. What is the relation between triggering angles of the thyristor of positive and negative converters. [10]

b) What are the applications of cyclo converters? [6]



Total No. of Questions : 6]

SEAT No. :

PA-693

[Total No. of Pages : 2

[5928]-148

M.E. (Electrical) (Power Electronics and Drives)

RESEARCH METHODOLOGY

(2017 Pattern)(Semester-I)(503304)

Time : 3 Hours]

[Max. Marks : 50

Instructions to the candidates:

- 1) *Attempt Q.1 or Q.2, Q.3 or Q.4, Q.5 or Q.6.*
- 2) *Neat diagrams must be drawn wherever necessary.*
- 3) *Figures to the right indicate full marks.*
- 4) *Use of logarithmic tables slide rule, Mollier charts, electronic pocket calculator and steam tables is allowed.*
- 5) *Assume suitable data, if necessary.*

Q1) a) Justify the necessity of literature review in the formulation of research problem. **[6]**

b) Write a short note with example on simple regression analysis. **[6]**

c) Explain the following terms: **[6]**

- i) Copyright
- ii) Royalty
- iii) Trade related aspects of IPR

OR

Q2) a) Explain the following terms: **[6]**

- i) Monograph
- ii) Treatise

b) Define the parameters used for measure of central tendency in statistical analysis of data. **[6]**

c) Explain the procedure of Making title page, writing mathematical equations, including graphics in report using LATEX. **[6]**

P.T.O.

- Q3)** a) Write a short note on following types of technical papers. [8]
i) Journal papers
ii) Conference paper
b) Explain in detail the organization and flow of project report. [8]

OR

- Q4)** a) Write a short note on following types of technical papers [8]
i) Survey papers
ii) Poster papers
b) Explain the different steps involved in preparation of research proposal. [8]

- Q5)** a) Explain the various ways of visual aids for oral presentation. [8]
b) Explain the significance of illustration and tables, referencing and footnotes in report writing. [8]

OR

- Q6)** Write a short note on: [16]
a) Importance of effective communication
b) Technical report
c) Thesis



Total No. of Questions : 06]

SEAT No. :

PA-694

[Total No. of Pages : 2

[5928]-149

M.E. (Electrical) (Power Electronics & Drives)

AC & DC DRIVES

(2017 Pattern) (Semester - II) (503307)

Time : 3 Hours]

[Max. Marks : 50

Instructions to the candidates:

- 1) *Answer Q1 or Q2, Q3 or Q4, Q5 or Q6.*
- 2) *Neat diagram must be drawn wherever necessary.*
- 3) *Figures to the right side indicate full marks.*
- 4) *Assume suitable data if necessary.*

- Q1)** a) Explain thermal model of motor for heating and cooling. [6]
- b) Discuss speed control of D.C. separately excited motor fed from single phase full converter for continuous mode operation. [6]
- c) Explain the motoring control and regenerative braking operation of a separately excited dc motor fed from chopper. [6]

OR

- Q2)** a) Explain the four quadrant operations of an electric drive for hoist application. [6]
- b) Discuss various types of braking system followed in D.C. drives. [6]
- c) Explain with suitable diagram working principle of VSI fed induction motor. [6]
- Q3)** a) Explain principle of field oriented control of induction motor. [4]
- b) Explain direct vector control. [4]
- c) Derive expression for flux vector. [4]
- d) Explain sensor less vector control. [4]

OR

P.T.O.

- Q4)** a) Explain what do you understand by D.C. Motor analogy. [4]
b) Explain indirect vector control of induction motor. [4]
c) Explain PWM switching & SVM switching. [4]
d) Describe the advantages and major applications of vector controlled induction motors. [4]

- Q5)** a) Explain working principle of BLDC motor. [4]
b) What are the main features of stepper motors which are responsible for its wide spread use? [4]
c) What are the advantages of BLDC motor over conventional D.C. drives? [4]
d) Explain principle of operation of PMDC drives. [4]

OR

- Q6)** a) Describe the main control strategies of BLDC motors. [4]
b) What are the main types of stepper motors? [4]
c) Write the main applications of BLDC motors. [4]
d) Explain principle of torque generation in BLDC motors. [4]



Total No. of Questions : 5]

SEAT No. :

PA-695

[Total No. of Pages : 2

[5928]-150

M.E. Electrical (Power Electronics and Drives)

POWER CONVERTERS - II

(2017 Pattern) (Semester - II) (503308)

Time : 3 Hours]

[Max. Marks : 50

Instructions to the candidates:

- 1) *Figures to the right indicate full marks.*
- 2) *Neat diagrams must be drawn wherever necessary.*
- 3) *Assume suitable data, if necessary.*

Q1) Answer any three.

[18]

- a) Elaborate how PWM pulses are generated for single phase and three phase inverters.
- b) Explain with circuit diagram diode clamped multilevel inverter.
- c) Explain the necessity and importance of soft switching in converters.
- d) Explain concept of flyback converter with neat circuit diagram and waveforms.

Q2) a) Design a heat sink for a dc-dc Boost system.

[10]

- b) For the Buck converter, find the peak device current, the peak dissipation and the case to ambient thermal resistance. Use maximum junction temperature of 150 °C and the ambient temperature to be at 40°C and the case temperature should not exceed 60°C. Duty ratio is 40%. The thermal impedance at 400mS is $Z=0.4 \text{ } ^\circ\text{C/W}$.

[6]

OR

Q3) Write a short notes on:

[16]

- a) conduction,
- b) convection
- c) radiation,
- d) mass transport.

P.T.O.

- Q4) a)** An inductor is to be designed to meet the following specifications: $L = 4$ milli henries; $I_{rms} = 4$ A sinewave ; $f = 100$ kHz; $T_s = 90$ C and $T_a = 30$ C. The inductor is to be fabricated on a double-E core made from 3F3 ferrite. The windings are made with foil conductors which have $k_{cu} = 0.6$. A core size of $a = 2$ cm is chosen for the design. The emissivity E of the surface of the completed inductor equals 0.9 and that the vertical height is $3a$. [8]
- i) Determine the conductor cross-sectional area, A_{cu} , and number of turns N . Ignore eddy currents and the proximity effect.
 - ii) Specify the length of the air gaps in the core. Assume four distributed air gaps.
- b) Explain turn on snubber circuit with neat circuit diagram. [8]

OR

- Q5) a)** Explain with flow chart single pass inductor design procedure. [8]
- b) Explain turn off snubber and overvoltage snubber with circuit diagram. [8]



Total No. of Questions : 5]

SEAT No. :

PA-696

[Total No. of Pages : 2

[5928]-151

M.E. (Electrical) (Power Electronics and Drives)
ADVANCED CONTROL SYSTEMS
(2017 Pattern) (Semester - II) (503309)

Time : 3 Hours]

[Max. Marks : 50

Instructions to the candidates:

- 1) *Neat diagrams must be drawn wherever necessary.*
- 2) *Figures to the right indicate full marks.*
- 3) *Assume suitable data, if necessary.*
- 4) *Use of electronic calculator is allowed.*

- Q1)** a) Explain in depth, the Ziegler-Nichols method for tuning PID controller. [4]
b) Explain the concept of sliding mode control with example. [5]

OR

- Q2)** Consider the unity feedback control system with PID controller in forward path. The transfer function of PID controller $G_c(s)$ and plant transfer function $G(s)$ are given below. Obtain K_p , T_i and T_d using Ziegler-Nichols rules. [9]

$$G_c(s) = K_p \left(1 + \frac{1}{T_i s} + T_d s \right), G(s) = \frac{1}{s(s+1)(s+5)}$$

- Q3)** a) Explain in detail sliding mode observer. [4]
b) Explain observer based sliding control for Buck DC/DC converter in detail. [5]

- Q4)** a) Describe the variable gradient method for constructing the Lyapunov's function to determine the stability of non linear system. [8]

OR

- a) Describe the Krasovkii's method for constructing the Lyapunov's function to determine the stability of non linear system. [8]

P.T.O.

- b) Discuss the following terms pertaining in sense of Lyapunov's stability criterion: [8]
- i) Asymptotic stable system
 - ii) Asymptotic stable in large
 - iii) Limit cycles

Q5) a) With example clearly explain Normal form and Zero dynamics in concern with the input output linearization. [8]

b) Write the short note on Input-State linearization. [8]

OR

b) Write the short note on Input-Output linearization. [8]



Total No. of Questions : 6]

SEAT No. :

PA-697

[Total No. of Pages : 2

[5928]-152

**M.E. (Electrical) (Power Electronics & Drives)
SPECIAL APPLICATIONS OF POWER ELECTRONICS
(2017 Pattern) (Semester - III) (603301)**

Time : 3 Hours]

[Max. Marks : 50

Instructions to the candidates:

- 1) *Attempt Q1 or Q2, Q3 or Q4, Q5 or Q6.*
- 2) *Neat diagrams must be drawn wherever necessary.*
- 3) *Figures to the right indicate full marks.*
- 4) *Use of logarithmic tables slide rule, Mollier charts, electronic pocket calculator and steam tables is allowed.*
- 5) *Assume suitable data, if necessary.*

- Q1)** a) Explain the working of TCR. [6]
b) Explain the concept and objectives of smart city. [6]
c) Explain construction of multi terminal HVDC system with suitable diagram. [6]

OR

- Q2)** a) Explain HVDC light configuration with neat diagram. [6]
b) Describe Wide Area Network (WAN) in detail. [6]
c) Write short note on: Sensors and actuators used for signal acquisition and control. [6]

- Q3)** a) Write down integration and interconnection concerns of distributed energy resources. [8]
b) How PMUs are used in wide area monitoring protection and control (WAMPAC). [8]

OR

P.T.O.

- Q4) a)** Explain the following in context with Smart Grid. **[12]**
- i) Concept of Smart Grid
 - ii) Need of Smart Grid
 - iii) Functions of Smart Grid
 - iv) Microgrids

- b) Write short note on PMU. **[4]**

- Q5) a)** Explain SMPS with diagram. **[8]**
- b) Identify the various voltage disturbances likely to occur in power system operation. How can it be control using uninterrupt power supplies? Explain its working with the help of block diagram. **[8]**

OR

- Q6)** Describe following power electronics applications using various possible techniques. **[16]**
- i) AC - DC locomotives
 - ii) Electronic Ballast

Total No. of Questions : 6]

SEAT No. :

PA-2676

[Total No. of Pages : 1

[5928]-153

M.E. (Electrical) (Power Electronics & Drives)
ENERGY MANAGEMENT AND POWER QUALITY
(2017 Pattern) (Semester - III) (603302)

Time : 3 Hours]

[Max. Marks : 50

Instructions to the candidates :

- 1) *Solve Q.1 or Q.2, Q.3 or Q.4 and Q.5 or Q.6.*
- 2) *Figures to the right side indicate full marks.*
- 3) *Use of Calculator is allowed.*
- 4) *Assume Suitable data if necessary.*

- Q1)** a) Explain energy saving methods and optimal selection criteria of Pumps.[9]
b) Explain with diagram all types of Earthing Systems used. [9]

OR

- Q2)** a) Discuss various control equipments used for motors to increase Energy efficiency. [9]
b) Explain VFD operation with advantages and disadvantages. [9]

- Q3)** a) Enlist various causes of voltage flicker on power line? [8]
b) Explain Voltage sags and interruptions phenomenon on power line. [8]

OR

- Q4)** a) Enlist the different power quality monitoring standards and explain them.[8]
b) Write note on power quality state estimations. [8]

- Q5)** a) Explain the application of intelligent system in power quality monitoring.[8]
b) Enlist detailed steps/procedure to design a harmonic filter. [8]

OR

- Q6)** a) Explain reasons for carrying out power quality monitoring. [8]
b) Write detail note on Power quality monitoring standards. [8]



Total No. of Questions : 3]

SEAT No. :

PA-698

[Total No. of Pages : 2

[5928]-154

M.E. (Electrical Power System)

COMPUTER APPLICATIONS IN POWER SYSTEM

(2017 Pattern) (Semester - I) (503201)

Time : 3 Hours]

[Max. Marks : 50

Instructions to the candidates:

- 1) *All questions are compulsory.*
- 2) *Neat diagrams must be drawn wherever necessary.*
- 3) *Figures to the right indicate full marks.*
- 4) *Use of calculator is allowed.*
- 5) *Assume suitable data if necessary.*

Q1) Solve any THREE.

[18]

- a) What are the theorems used in optimizing multivariable functions?
- b) Draw surface constraint diagram showing behavior and side constraints. Also indicate bounded and unbounded, acceptable and unacceptable points on surface constraint.
- c) Explain decoupled load flow method with assumptions.
- d) Derive the equation used in AC-DC load flow analysis.

Q2) Solve any TWO.

[16]

- a) State economical dispatch problem
 - i) Unconstrained without loss
 - ii) Constrained without loss
 - iii) Unconstrained with loss
 - iv) Constrained with loss
- b) The cost characteristic of two units in a plant are

$$C_1 = 0.4P_1^2 + 160P_1 + K_1 \text{ Rs/ h}$$

$$C_2 = 0.45P_2^2 + 120P_2 + K_2 \text{ Rs/ h}$$

P.T.O.

Where P_i is power generated by i^{th} station in MW. Find the optimal load allocation between the two units, when the total load is

- i) 162.5 MW
- ii) 200 MW
- c) Explain solution economic load dispatch problem using Newton-Raphson method.

Q3) Solve any TWO.

[16]

- a) Derive economic dispatch using exact loss formula.
- b) Derive transmission loss coefficient using sensitivity factor.
- c) Show that transmission loss formula is a function of generation and load.



Total No. of Questions : 5]

SEAT No. :

PA-699

[Total No. of Pages : 2

[5928]-155

M.E. (Electrical Power Systems)

POWER SECTOR ECONOMICS & MANAGEMENT

(2017 Pattern) (Semester - I) (503202)

Time : 3 Hours]

[Max. Marks : 50

Instructions to the candidates:

- 1) *Attempt Q.1 or Q.2, Q.3 or Q.4, Q.5 or Q.6.*
- 2) *Neat diagrams must be drawn wherever necessary.*
- 3) *Figures to the right indicate full marks.*
- 4) *Use of logarithmic tables slide rule, Mollier charts, electronic pocket calculator and steam tables is allowed.*
- 5) *Assume suitable data, if necessary.*

Q1) Attempt any three of the following. **[18]**

- a) Give salient features of electricity Act 2003.
- b) Discuss performance based regulation and price cap regulation.
- c) Judge the economic feasibility for following investment of Rs. 7,50,000 and cash inflows are 1,50,000, 1,25,000, 1,75,000, 2,00,000 and 2,00,000. Take discounting rate as 10%.
- d) Explain interruptible tariff and life line tariff.
- e) Explain models based on contractual arrangements in power sector.
- f) Explain role of Independent system operators in power system.

Q2) a) Explain the operation of electricity markets. How market efficiency is calculated? **[8]**

- b) Explain terms with suitable examples spot pricing, location marginal pricing, market clearing price. **[8]**

OR

Q3) a) Explain competitive and non competitive markets in power sector. **[8]**

- b) Explain ancillary service management. **[8]**

P.T.O.

- Q4) a)** Discuss methods used for transmission services pricing. [8]
- b) Explain roles of national and state load dispatch centres. [8]

OR

- Q5) a)** Discuss the cost components required to be included while determination of cost of transmission services. [8]
- b) Explain following terms. [8]
- i) Available transfer capacity.
 - ii) Transmission reliability margin.
 - iii) Transmission rights.
 - iv) Arbitrage.



Total No. of Questions : 6]

SEAT No. :

PA-700

[Total No. of Pages : 2

[5928]-156

M.E. (Electrical) (Power Systems)
POWER SYSTEM MODELING
(2017 Pattern) (Semester-I) (503203)

Time : 3 Hours]

[Max. Marks : 50

Instructions to the candidates:

- 1) Solve Total Three questions. Answer 1 question from Q1 or Q2, Q3 or Q4, and Q5 or Q6 each.
- 2) Assume suitable data, if necessary.
- 3) Write down all the assumptions made.
- 4) Give $F^{abc} = [P] F^{dq0}$, where Park's transformation

$$[P] = \begin{bmatrix} k_d \cos \theta & k_q \sin \theta & k_0 \\ k_d \cos \left(\theta - \frac{2\pi}{3} \right) & k_q \sin \left(\theta - \frac{2\pi}{3} \right) & k_0 \\ k_d \cos \left(\theta + \frac{2\pi}{3} \right) & k_q \sin \left(\theta + \frac{2\pi}{3} \right) & k_0 \end{bmatrix}$$

(Where, $\mathbf{K}_d = \mathbf{K}_q = \sqrt{2/3}$ and $\mathbf{K}_0 = \sqrt{1/3}$)

Q1) Derive the model 'pi' circuit medium transmission line. Draw its equivalent circuit diagram. Also comment about the symmetry of the model. Write down assumptions involved in it if any. [18]

OR

Q2) Discuss need of excitation system in power system. Explain effect of change in excitation on system parameters with the help of suitable phasor diagram. [18]

Q3) Discuss with the help of suitable diagram working of stationary diode excitation control scheme of alternator. [16]

OR

Q4) Compare with the help of suitable diagram working of static and brushless excitation control Scheme of alternator. [16]

P.T.O.

Q5) Develop the model of long transmission line with the help of appropriate transformation using α - β variables. Discuss about the assumptions and approximations involved in it. **[16]**

OR

Q6) State need of Clarke's transformation and Kron's transformation and write about their applications in power system. Also write down their relationship with Park's transformation. **[16]**



Total No. of Questions : 6]

SEAT No. :

PA-701

[Total No. of Pages : 2

[5928]-157

M.E. Electrical (Power Systems)

RESEARCH METHODOLOGY

(2017 Pattern) (Semester - I) (503204)

Time : 3 Hours]

[Max. Marks : 50

Instructions to the candidates:

- 1) *Answer any one question from each pair of questions : Q.1 & Q.2, Q.3 & Q.4, Q.5 & Q.6.*
- 2) *Figures to the right side indicate full marks.*
- 3) *Neat diagrams must be drawn wherever necessary.*
- 4) *Assume suitable data, if necessary.*

- Q1)** a) What is the significance of the survey paper? [4]
b) Explain the different types of literatures. [4]
c) How to avoid plagiarism in research? [4]
d) Explain the standard form of the linear programming problem. [6]

OR

- Q2)** a) What is the significance of research report writing. [6]
b) What is the importance of a literature survey in defining the research problem? [4]
c) How the research can be commercialized? [4]
d) Define hyperplane and convex set. [4]

- Q3)** a) Explain the characteristics of a Constrained Problem. [8]
b) Explain convex programming problem. [8]

OR

- Q4)** a) Explain the basic approach of the penalty function method. [8]
b) Give classification of constraint optimization techniques. [8]

P.T.O.

Q5) a) Explain particle swarm optimization with example. [8]

b) Explain ant colony optimization algorithm with example. [8]

OR

Q6) a) Compare genetic algorithm and simulated annealing. [8]

b) What is linear regression? Explain with mathematical expressions. [8]



Total No. of Questions : 08]

SEAT No. :

PA-702

[Total No. of Pages : 2

[5928]-158

M.E. (Electrical Engineering) (Power Systems)

POWER SYSTEM DYNAMICS

(2017 Pattern) (Semester - II) (503207)

Time : 3 Hours]

[Max. Marks : 50

Instructions to the candidates:

- 1) *Attempt Q1 or Q2, Q3 or Q4, Q5 or Q6, Q7 or Q8.*
- 2) *Figures to the right indicate full marks.*
- 3) *Neat diagram must be drawn wherever necessary.*
- 4) *Assume suitable data, if necessary.*
- 5) *Use of non-programmable calculator is allowed.*

Q1) Draw the block diagram of states of operation of power system and security as per the classification proposed by Liacoo, Fink and Carlson. [12]

OR

Q2) State and explain factors affecting voltage instability and voltage collapse.[12]

Q3) Explain power system stabilizer with the help of suitable block diagram. State the guidelines for the selection of parameters of individual blocks. [14]

OR

Q4) Describe classical model of multi machine system useful for transient stability analysis. [14]

Q5) Show the synchronous machine model as a two port network & Derive the stator voltage equations of synchronous machine model. [12]

OR

P.T.O.

Q6) Derive the rotor mechanical equations of synchronous machine model. State the assumptions made. [12]

Q7) Derive the stator voltage equations with excitation system for a small signal machine model. Draw the block diagram of excitation system. [12]

OR

Q8) State the Heffron-Phillips constants & their significance to maintain system stability for the SIMB system. Draw its overall block diagram [12]



Total No. of Questions : 6]

SEAT No. :

PA-703

[Total No. of Pages : 1

[5928]-159

M.E. (Electrical) (Power System)

POWER SYSTEM PLANNING & RELIABILITY

(2017 Pattern) (Semester - II) (503208)

Time : 3 Hours]

[Max. Marks : 50

Instructions to the candidates:

- 1) *Attempt Q.No.1 or Q.No.2, Q.No.3 or Q.No.4, Q.No. 5 or Q.No. 6.*
- 2) *Figures to the right indicates full marks.*
- 3) *Assume suitable data, if necessary*
- 4) *Neat diagrams must be drawn wherever necessary.*

- Q1)** a) Explain co-relation method of load forecasting. [6]
b) Explain weather sensitive forecasting in details. [6]
c) Explain Markov process in details for reliability evaluation. [6]

OR

- Q2)** a) Explain steepest descent method for reliability evaluation. [6]
b) A power system having 5 units of 100 MW each with of FOR - 0.03. The load model is linear in nature having maximum load of 400 MW and minimum load of 150 MW. Calculate the system LOLE. [6]
c) Explain generation system model. [6]

- Q3)** a) Explain the role of construction monitoring of transmission line projects. [8]
b) Explain goals of short term transmission planning in details. [8]

OR

- Q4)** a) Explain load point indices in a transmission line. [8]
b) Write short note on analysis of causes of failure of transmission line.[8]

- Q5)** a) Explain effects of weather on distribution system. [8]
b) Explain network re-configuration method in distribution systems. [8]

OR

- Q6)** a) Explain the effect of weather in distribution system planning in details.[8]
b) Explain effects of dis-connectors, circuit breakers and isolators on distribution systems. [8]



Total No. of Questions: 10]

SEAT No. :

PA-592

[5928]-16

[Total No. of Pages : 2

M.E. (Civil-Environmental Engineering)
SOLID WASTE AND HAZARDOUS WASTE MANAGEMENT
(2017 Pattern) (Semester-II) (501069)

Time : 3 Hours]

[Max. Marks : 50

Instructions to the candidates:

- 1) *Solve question 1 or 2, 3 or 4, 5 or 6, 7 or 8, 9 or 10.*
- 2) *Each question carries equal marks.*
- 3) *Figures to the right side indicate full marks.*
- 4) *Use of Calculator is allowed.*
- 5) *Assume Suitable data if necessary.*

Q1) Explain in detail, the direct load and discharge load Transfer station. **[10]**

OR

Q2) Explain in detail, the functional elements of Solid Waste Management. **[10]**

Q3) Describe in detail, the design and operation of a sanitary landfill with a neat sketch. **[10]**

OR

Q4) a) Describe in detail, the factors which affect production of leachate and landfill gas in the landfill? **[5]**

b) Explain in detail, area method of landfilling. **[5]**

Q5) Write a detailed note on material recovery facility. **[10]**

OR

Q6) What is biomedical waste? Explain in detail, the methods of collection and treatment. **[10]**

P.T.O.

Q7) Define recycling of solid waste. Discuss in detail, the purpose of recycling of municipal solid waste. **[10]**

OR

Q8) Explain in detail, about drop off center and buy back center. **[10]**

Q9) Write a detailed note on TCLP test. **[10]**

OR

Q10) Explain in detail, the labeling and handling of hazardous waste. **[10]**



Total No. of Questions : 05]

SEAT No. :

PA-704

[Total No. of Pages : 2

[5928]-160

M.E. (Electrical) (Power Systems)

HVDC AND FLEXIBLE AC TRANSMISSION

(2017 Pattern) (Semester - II) (503209)

Time : 3 Hours]

[Max. Marks : 50

Instructions to the candidates:

- 1) *Neat diagram must be drawn wherever necessary.*
- 2) *Assume suitable data, if necessary.*
- 3) *Figures to the right indicates full marks.*
- 4) *Use of calculators is allowed.*

Q1) Solve any Three :

[3 × 6 = 18]

- a) Discuss the different types of MTDC systems with neat diagram.
- b) Write short note on protection of dc line.
 - i) Detection of line faults.
 - ii) DC Breakers.
- c) What are the different control characteristics of HVDC link? Elaborate each with suitable diagram.
- d) Explain HVDC protection schemes used against over-voltage and overcurrent.
- e) How the economic choice of voltage level selected in DC transmission system for a fixed power transmission as compared with EHVAC lines?

Q2) a) Prove that SVC can be used to enhance the power transfer capacity of a transmission line. **[8]**

- b) With the help of power angle curve explain how transient stability is improved with the help of series controllers. **[8]**

OR

P.T.O.

- Q3)** a) Explain the working of STATCOM. Compare its V-I characteristic with SVC. [8]
- b) Compare HVDC light with HVDC transmission system with advantages & disadvantages. [8]

- Q4)** a) How series FACTS devices respond to the problem of Sub Synchronous Resonance? [8]
- b) Explain the steady state UPFC model for power flow studies. [8]

OR

- Q5)** a) Explain how a UPFC is different than a simple VSC. [8]
- b) Explain the block diagram of overall UPFC control structure. [8]



Total No. of Questions : 5]

SEAT No. :

PA-705

[Total No. of Pages : 2

[5928]-161

M.E. (Electrical) (Power Systems)
ADVANCED POWER SYSTEM PROTECTION
(2017 Pattern) (603201) (Semester - III)

Time : 3 Hours]

[Max. Marks : 50

Instructions to the candidates :

- 1) *Neat diagrams must be drawn wherever necessary.*
- 2) *Assume Suitable data if necessary.*
- 3) *Figures to the right side indicate full marks.*
- 4) *Use of Calculators is allowed.*

Q1) Solve any Three :

[3 × 6 = 18]

- a) Explain features of PC-based integrated software for short circuit studies.
- b) Assume that secondary burden of a 300:5 class C CT is 5Ω . The relay setting is 2A and the CT ratio is 300/5, secondary resistance 0.15Ω & corresponding exciting current is 0.04A. Calculate the primary current required to operate the relay?
- c) What is the function of a tuning inductor & ferro resonance suppression circuit in CCVT?
- d) Differentiate between measuring and protective CT. Derive expression for ratio error and phasor angle error of a P.T.
- e) Why short circuit studies are important? Explain development of algorithm for the short circuit studies.

Q2) a) With a neat block diagram explain hardware design of digital protection of transmission line. Explain function of each block. **[8]**

b) Explain Fourier analysis and least error squared technique. **[8]**

OR

Q3) a) Explain protection of transformer using digital filtering scheme. **[8]**

b) Explain digital protection scheme of synchronous generator based upon injection of sub synchronous component in the rotor circuit. **[8]**

P.T.O.

- Q4)** a) Explain co-ordination criteria of directional instantaneous IDMT over current relay for two terminal lines. [8]
- b) Explain importance of relay setting and Relay co-ordination. [8]

OR

- Q5)** a) Write a note on salient features and applications of computer graphics display. [8]
- b) Explain why only middle 60% of the double-end-fed line gets instantaneous distance protection from both ends in a three-stepped distance scheme.[8]



Total No. of Questions : 5]

SEAT No. :

PA-706

[Total No. of Pages : 2

[5928]-162

M.E. Electrical (Power Systems)

**POWER QUALITY ASSESSEMENT AND MITIGATION
(2017 Pattern) (Semester - III) (603202)**

Time : 3 Hours]

[Max. Marks : 50

Instructions to the candidates:

- 1) *Neat diagrams must be drawn whenever necessary.*
- 2) *Figures to the right indicate full marks.*
- 3) *Use of logarithmic tables slide rule, Mollier charts, electronic pocket calculator and steam tables is allowed.*
- 4) *Assume suitable data, if necessary.*

Q1) Attempt any three of the following. **[18]**

- a) What are the symptoms of poor power quality? Will these problems can be minimized with good grounding practices? How?
- b) Explain concept of ferroresonance. How this affect power system? How it can be avoided?
- c) Explain CBEMA and ITI curves.
- d) Explain half cycle and one cycle rms methods used for sag assessment.
- e) Explain detrimental impacts of harmonics on power system components.
- f) Explain term distortion power, displacement and distortion powerfactor, total demand distortion.

Q2) a) Explain principle of active filtering. With suitable example/diagram explain shunt active filter. **[8]**

b) Explain tunned filter and notch filters used for harmonic filtering. **[8]**

OR

Q3) a) Discuss resonance in respect of harmonics. **[8]**

b) Explain computer tools for harmonic analysis. **[8]**

P.T.O.

- Q4)** a) Explain typical instrumentative used for power quality monitoring. [8]
b) Explain different approaches used for power quality monitoring. [8]

OR

- Q5)** a) Discuss requirements for transient monitoring and event recording. [8]
b) Discuss different indices used for power quality monitoring and assessment. [8]

Total No. of Questions : 8]

SEAT No. :

PA-707

[Total No. of Pages : 2

[5928]-163

M.E. (Electronics) (Digital System)
ANALOG & DIGITAL CMOS DESIGN
(2017 Pattern) (Semester - I) (504101)

Time : 3 Hours]

[Max. Marks : 50

Instructions to the candidates:

- 1) *Solve any five questions.*
- 2) *Neat diagrams must be drawn wherever necessary.*
- 3) *Figures to the right side indicate full marks.*
- 4) *Assume suitable data, if necessary.*

- Q1)** a) What are MOSIS Scalable CMOS Design Rules? What are the advantages using it? [5]
- b) Explain advantages of stick diagram and draw it for logic : $(\overline{A+B.C})$ [5]
- Q2)** a) What do you mean by photolithography and Ion implantation? [5]
- b) Explain need of layout Design rules and list them with proper sketches. [5]
- Q3)** a) What is RC-delay model? Illustrate it with example of any circuit. [5]
- b) Explain the various components of Delay in Logic gates. [5]
- Q4)** a) What are the efforts to compensate delay in Logic gates? [5]
- b) Differentiate Logical, Electrical and Parasitic delay. [5]
- Q5)** a) With neat diagram explain Cascode Amplifiers. What are the advantages? [5]
- b) Explain the implementation of [5]
- i) Diode and
 - ii) Current Sinks and Voltage Source.

P.T.O.

- Q6)** a) Write short notes on [5]
i) Current mirrors,
ii) Voltage Reference
- b) Explain the operation of sense Amplifier in SRAM & DRAM. [5]
- Q7)** a) Draw and explain BiCMOS Circuits. [5]
b) With schematic diagram, explain Sense Amplifier Circuits. [5]
- Q8)** a) Compare different logic circuit families. [5]
b) What are the specific methodologies used for Low Power Logic Design? [5]



Total No. of Questions : 8]

SEAT No. :

PA-708

[Total No. of Pages : 2

[5928]-164

**M.E. (Electronics) (Digital Systems)
MULTIRATE SIGNAL PROCESSING
(2017 Pattern) (Semester - I) (504102)**

Time : 3 Hours]

[Max. Marks : 50

Instructions to the candidates:

- 1) *Solve any five questions.*
- 2) *Assume suitable data if necessary.*
- 3) *Figures to the right indicate full marks.*

- Q1)** a) For a two stage decimator, $F_a = 240\text{kHz}$, $F_{wp} = 8\text{kHz}$, $D = 30$. Passband ripple = 0.03 dB, stopband ripple = 0.01 dB. Highest frequency of interest is 3kHz. Calculate Band edge frequency, transition width, Δ_p & Δ_s at each stage. [5]
- b) What are the characteristics of polyphase filters? How are the polyphase structure efficient? [5]
- Q2)** a) Explain the use of sub band coding for speech. What is the advantage of sub band coding? [5]
- b) Explain design of phase shifter in multirate systems. [5]
- Q3)** a) What is STFT? How is it suitable for speech analysis? [5]
- b) Explain multi resolution analysis. [5]
- Q4)** a) Define a gradient in the steepest descent algorithm. What are the limitations of this algorithm. [5]
- b) State & explain the LPF and HPF for Daubechies wavelet. [5]
- Q5)** a) What are wavelet packets? What are applications of it? [5]
- b) Explain the steps in denoising using DWT. [5]

P.T.O.

- Q6)** a) Explain a design of DFT filter bank. [4]
b) Explain how to use wavelet transform for image compression. [4]
c) Compare wavelet transform & STFT. [2]
- Q7)** a) Design a Low pass filter with cut off frequency of 1000 Hz for a speech signal. Signal is sampled with 8 kHz sampling frequency and 256 samples are taken with 256 point DCT. [5]
b) How is the implementation of decimator and interpolator made efficient. [5]
- Q8)** a) Explain applications of multirate DSP in ADC/DAC. [2]
b) Calculate 2-level decomposition using Haar wavelet of $h(n) = \{1 \ 2 \ 3 \ 7 \ 8 \ 21\}$, comment on its every compaction. [4]
c) What are the properties of DCT. Explain any two in detail. [4]



Total No. of Questions : 8]

SEAT No. :

PA-709

[Total No. of Pages : 2

[5928]-165

**M.E. (Electronics) (Digital System)
EMBEDDED SYSTEM DESIGN
(2017 Pattern) (Semester - I) (504103)**

Time : 3 Hours]

[Max. Marks : 50

Instructions to the candidates:

- 1) *Answer any five questions.*
- 2) *Neat diagrams must be drawn wherever necessary.*
- 3) *Figures to the right indicate full marks.*
- 4) *Assume suitable data, if necessary.*

- Q1)** a) Explain design metrics for embedded systems. [4]
b) Explain the Bluetooth protocol stack for embedded systems. [4]
c) Describe features of ARM-Cortex series. [2]
- Q2)** a) List different types of life cycle models in embedded system design and explain any one in detail. [4]
b) Draw and explain architecture of LPC-1768. [4]
c) Explain the bit fields of standard CAN BUS protocol. [2]
- Q3)** a) Compare VxWorks and Micro-c/os - II. [4]
b) Explain the Android technology, structure & applications. [4]
c) Explain the significance of watchdog for Task execution. [2]
- Q4)** a) Explain the methods of task synchronization in RTOS. [4]
b) How will you develop an Android application? [4]
c) Enlist different kernel services of RTOS. [2]
- Q5)** a) What are the steps to implement device driver for blinking of LED. [4]
b) Explain Linux kernel construction. [4]
c) What are the advantages of Embedded Linux? [2]

P.T.O.

- Q6)** a) What are the steps to implement device driver for LCD. [4]
b) Explain device driver and it's types. [4]
c) Explain the procedure for porting linux on ARM. [2]
- Q7)** a) Explain the software and hardware architecture of Digital camera. [6]
b) Explain importance of EMI/RFI certification in embedded product. [4]
- Q8)** a) Explain automatic metering system in detail. [6]
b) Explain the testing and failure analysis of Embedded products. [4]



Total No. of Questions : 9]

SEAT No. :

PA-710

[Total No. of Pages : 2

[5928]-166

M.E. (Electronics) (Digital Systems) (Electronics and E & TC All Branches)

RESEARCH METHODOLOGY

(2017 Pattern) (Semester - I) (504104)

Time : 3 Hours]

[Max. Marks : 50

Instructions to the candidates:

- 1) *Answer any 5 out of all questions.*
- 2) *Figures to the right side indicate full marks.*
- 3) *Draw neat diagram wherever necessary.*
- 4) *Assume suitable data, if necessary.*

- Q1)** a) What is the necessity of defining a research problem? Explain. [5]
b) Write a short note on. [5]
i) Simple Random Sampling
ii) Systematic Sampling
- Q2)** a) What are the problems encountered by Researchers in India? [5]
b) What are the Techniques Involved in defining a problem? [5]
- Q3)** a) What is the necessity of defining a research problem? Explain. [5]
b) Explain the meaning and significance of a Research design. [5]
- Q4)** Explain the meaning of the following in context of Research design. [10]
a) Extraneous variables;
b) Confounded relationship;
c) Research hypothesis;
d) Experimental and Control groups;
e) Treatments.

P.T.O.

Q5) a) Describe some of the important research designs used in experimental hypothesis-testing Research study. [5]

b) What are the guiding considerations in the construction of questionnaire? Explain. [5]

Q6) How would you differentiate between simple random sampling and complex random Sampling designs? Explain clearly giving examples. [10]

Q7) Distinguish between:

a) Cluster and area sampling. [5]

b) Systematic and Stratified Sampling. [5]

Q8) Write short notes on:

a) Likert-type scale; [5]

b) Stapel scale [5]

Q9) Experimental method of research is not suitable in management field. Discuss, what are the Problems in the introduction of this research design in business Organization? [10]



Total No. of Questions : 8]

SEAT No. :

PA-711

[Total No. of Pages : 2

[5928]-167

M.E. (Electronics) (Digital Systems)

ADVANCED DSP PROCESSORS

(2017 Pattern) (Semester - II) (504107)

Time : 3 Hours]

[Max. Marks : 50

Instructions to the candidates:

- 1) *Answer any five questions out of eight questions.*
- 2) *Figures to the right indicate full marks.*
- 3) *Assume suitable data if necessary.*
- 4) *Use of scientific calculator is allowed.*

- Q1)** a) Explain Super Harvard architecture of DSP processor. [5]
b) Explain why floating point formats used for number representation in DSP. [5]
- Q2)** a) Discuss Bus structure of TMS320C54XX Processor. [5]
b) Draw the functional diagram of multiplier/ adder unit of TMS320C54XX processor. [5]
- Q3)** a) Write various fields of application of TMS320C6713 processor. [5]
b) Draw and explain TMS320C6713 architecture. [5]
- Q4)** a) Explain the stages in instruction pipeline of the processor? [5]
b) What is the use of circular addressing mode? [5]
- Q5)** a) Explain the features of visual DSP++? [5]
b) How to create and build a project in Code Composer Studio. [5]

P.T.O.

- Q6)** a) Explain the linking process rules in Visual DSP++. [5]
b) Explain memory map of Black fin BF533 processor. [5]
- Q7)** a) Discuss the selection criteria of Digital Signal Processor. [5]
b) Explain code generation tools provided by Code composer studio. [5]
- Q8)** a) Explain following processes: [5]
i) Sampling and quantization
ii) Coder-decoder
b) Explain the Coder and decoder in DSP processors. [5]



Total No. of Questions : 8]

SEAT No. :

PA-712

[Total No. of Pages : 2

[5928]-168

M.E. (Electronics-Digital Systems)

PLD'S & ASIC DESIGN

(2017 Pattern) (Semester - II) (504108)

Time : 3 Hours]

[Max. Marks : 50

Instructions to the candidates:

- 1) *Answer any five questions from the following.*
- 2) *Figures to the right indicate full marks.*
- 3) *Draw neat diagram wherever necessary.*
- 4) *Assume suitable data, if necessary.*

Q1) a) Explain methods of state diagram optimization. [5]

b) Explain Top down approach to System Design. [5]

Q2) a) Explain the resource sharing in a system design with suitable example.[5]

b) Explain the hardware and software co-design. [3]

c) What do you understand by data path and control path? [2]

Q3) a) Explain the structural and behavioral modeling techniques in VHDL with proper examples. [5]

b) Explain the sequential and concurrent statements in VHDL programming, with suitable examples. [5]

Q4) a) Explain the Complex Programmable Logic Device XC 9500 architecture. [5]

b) Explain the architecture and functional block of Cool Runner CPLD.[5]

P.T.O.

- Q5)** a) Explain FPGA Routing Architecture. [4]
b) What is Boundary scan? Explain Boundary scan method. [4]
c) What is Static timing analysis in FPGA? Why it is required? [2]
- Q6)** a) Explain the architecture of Xilinx Virtex - II. [5]
b) Which is the better method of designing state machines for FPGAs? Explain this method with one example. Write advantages and disadvantages of this method. [5]
- Q7)** a) Explain RTL to GDS-II flow. [5]
b) What does EDA tool refer to? Explain different EDA tools used in ASIC. [5]
- Q8)** a) Write short note on development of FPGA based serial/parallel converter. [5]
b) What is the standard cell based ASIC design? What is the role of cell libraries in ASIC design? In short, explain the steps in ASIC cell libraries design. [5]



Total No. of Questions : 8]

SEAT No. :

PA-713

[Total No. of Pages : 2

[5928]-169

M.E. (Electronics) (Digital Systems)

IMAGE PROCESSING AND COMPUTER VISION

(2017 Pattern) (Semester - II) (504109)

Time : 3 Hours]

[Max. Marks : 50

Instructions to the candidates:

- 1) *Attempt any five questions.*
- 2) *All questions carry equal marks.*
- 3) *Figures to the right indicate full marks.*

- Q1)** a) Explain in detail Hadamard transform. [5]
b) Write short note on Principal component analysis. [5]
- Q2)** a) Explain different types of histogram equalization techniques and draw Histogram for high contrast image. [5]
b) Write short note on Sobel operator and Prewitt operator. [5]
- Q3)** a) How color edges are detected, explain in detail. [5]
b) Write short note on segmentation in HIS color space. [5]
- Q4)** a) Why there is a need of color image compression? How it is done. [5]
b) Explain color image smoothing operation. [5]
- Q5)** a) Write short note on Image registration methods. [5]
b) What is image rectification and how it is done. [5]

P.T.O.

- Q6)** a) Which different point based methods are used in image registration?
Explain any one in detail. [5]
- b) Write short note on operational goal of image registration. [5]
- Q7)** a) Write short note on surface representation. [5]
- b) Explain Epipolar geometry for stereo correspondence. [5]
- Q8)** a) Write short note on multi-view stereo. [5]
- b) What is active range finding? Explain its application. [5]



Total No. of Questions : 8]

SEAT No. :

PA-593

[Total No. of Pages : 2

[5928]-17

M.E. (Civil-Environmental Engineering)
ENVIRONMENTAL IMPACT ASSESSMENT
(2017 Pattern) (Semester -III) (601073)

Time : 3 Hours]

[Max. Marks : 50

Instructions to the candidates:

- 1) *Solve Q1 or Q2, Q3 or Q4, Q5 or Q6 and Q7 or Q8.*
- 2) *Figures to the right side indicate full marks.*
- 3) *Draw neat figures wherever necessary.*
- 4) *Assume suitable data if necessary.*
- 5) *Use of scientific calculators is allowed.*

- Q1)** a) What are different stages of EIA? [4]
b) What are the different phases involve in life cycle assessment? Explain any one in detail. [5]

OR

- Q2)** a) What is screening in EIA process? [4]
b) Explain network method. [5]

- Q3)** a) Which background information of soil environment is required for road construction project during EIA? [4]
b) How prediction and assessment of impact for air is carried out for Thermal Power Plant project during EIA. [5]

OR

- Q4)** a) Explain different mitigation measures for Noise pollution. [4]
b) Write different Air quality standards and their permissible limits. [5]

- Q5)** a) List out different socioeconomic factors consider in EIA. Explain in details. [8]
b) What are the different methods for conflict management and dispute resolution? [8]

OR

P.T.O.

Q6) a) Discuss the role of public participation in environmental decision making in EIA. [8]

b) What are the problems in resettlement and rehabilitation? [8]

Q7) a) Discuss different provisions in the latest EIA notification. [8]

b) What is environmental management plan in EIA? [8]

OR

Q8) a) Explain in details different steps in public hearing carried out in EIA. [8]

b) How to obtain environmental clearance for construction project? [8]



Total No. of Questions : 7]

SEAT No. :

PA-714

[Total No. of Pages : 2

[5928]-170

M.E. (Digital System) (Electronics)
SYSTEM ON CHIP DESIGN
(2017 Pattern) (604101) (Semester - III)

Time : 3 Hours]

[Max. Marks : 50

Instructions to the candidates :

- 1) *Answer any five of the following questions.*
- 2) *Figures to the right side indicate full marks.*
- 3) *Draw neat diagrams wherever necessary.*
- 4) *Assume suitable data, if necessary.*

Q1) a) Compare different memories with respect to technology, speed and applications. [6]

b) List technical specifications of DDR-II RAM. [4]

Q2) a) Explain with example the Manchester Carry Chain. [6]

b) How to perform reconfiguration overhead analysis. [4]

Q3) a) Explain software configurable processors with suitable examples. [5]

b) Explain in detail the array processor model. [5]

Q4) a) Explain importance of low power, How power analysis plays a vital role in soc designs. [5]

b) Explain different sequential arcs with examples. [5]

Q5) a) Which IPS are used in soc chip design of digital still camera. [5]

b) Which techniques are employed for reading leakage power. [5]

P.T.O.

- Q6)** a) What is Fundamental philosophy to enabled synchronization. [5]
b) How synchronizers are over coming metastability problem? Explain with example. [5]
- Q7)** a) Explain dynamic voltage scaling. [5]
b) Draw a typical soc design flow. [5]



Total No. of Questions : 8]

SEAT No. :

PA-715

[Total No. of Pages : 1

[5928]-171

**M.E. (Electronics Digital Systems)
WIRELESS SENSOR NETWORK FOR IOT
(2017 Pattern) (Semester - III) (604102)**

Time : 3 Hours]

[Max. Marks : 50

Instructions to the candidates:

- 1) *Attempt any five questions.*
- 2) *Neat diagrams must be drawn wherever necessary.*
- 3) *Figures to the right indicate full marks.*
- 4) *Assume suitable data if necessary.*

- Q1)** a) Enlist any five challenges of wireless sensor network. [5]
b) Write short note on energy consumption in wireless sensor node. [5]
- Q2)** Draw and explain in detail real life application of WSN using IoT. [5]
- Q3)** a) Explain Zigbee protocol for WSN. [5]
b) Explain localization in sensor network. [5]
- Q4)** a) Explain Bluetooth protocol for WSN. [5]
b) Draw and explain frame structure for MAC. [5]
- Q5)** a) Explain low power and lossy network. [5]
b) Write short note on big data. [5]
- Q6)** a) Compare any five points between IPv4 and IPv6. [5]
b) Explain 6LoWPAN. [5]
- Q7)** a) Explain WebSocket protocol. [5]
b) Explain open Trust Protocol (OTrP) for WSN IOT. [5]
- Q8)** a) Write short note on MQTT protocol. [5]
b) Explain IOT application for health care application. [5]



Total No. of Questions : 8]

SEAT No. :

PA-716

[Total No. of Pages : 2

[5928]-172

M.E. (E & TC) (Communication Networks)

MODELLING AND SIMULATION OF COMMUNICATION

NETWORKS

(2017 Pattern) (Semester-I) (504501)

Time : 2 Hours]

[Max. Marks : 50

Instructions to the candidates:

- 1) *Answer any five questions.*
- 2) *Neat diagram must be drawn wherever necessary.*
- 3) *Figures to the right indicate full marks.*
- 4) *Use of electronic pocket calculator is allowed.*
- 5) *You are advised to attempt not more than Five questions.*
- 6) *Assume suitable data if necessary.*

- Q1)** a) Explain the graphical technique for post processing. [4]
b) What are different techniques of generate uniformly distributed random numbers? Explain multiplication algorithm with prime modulus. [4]
c) What is the role of simulation in communication system? [2]
- Q2)** a) What is up-sampling and down-sampling? Illustrate these concepts with reference to simulation of communication network. [4]
b) What are PN sequence generators? What are the properties of PN sequence generators? Why do we need them in simulating communication systems? [4]
c) What is direct component and quadrature component of a signal? [2]
- Q3)** a) What are parameters for the performance estimation in simulation? [4]
b) Compare and contrast the following techniques to test random number generators? [4]
i) Scatter plots
ii) Durbin-Watson Test
c) Explain the principle of multicarrier modulation OFDM. [2]

P.T.O.

- Q4)** a) Elaborate various methodologies used in mapping a problem into a simulation model. [4]
 b) What are correlated Gaussian numbers? Why do we need them? Explain any one technique to generate correlated Gaussian numbers in detail. [4]
 c) What are the steps in simulation and model building? [2]
- Q5)** a) What are the different techniques used to reduce run time of the Monte Carlo method? Hence explain importance of sampling. [4]
 b) Enlist factors to be considered while simulating nonlinearities. [4]
 c) Explain simulation model for simple communication (Assume any communication system) [2]
- Q6)** a) What is tapped delay line model for LTV system? How various tap gains are generated? [4]
 b) Explain random process model with reference to time varying system. [4]
 d) Why is semi analytic simulation technique used in network analysis? [2]
- Q7)** a) What are categories of a communication channel? Explain multipath fading in wireless communication channel. [4]
 b) What are the various parameters that must be considered while simulating a radio channel? [4]
 c) What is discrete memory less channel model? [2]
- Q8)** a) Write an algorithm to demonstrate two state Markov model for discrete channel with memory. [4]
 b) With an example explain Monte Carlo Estimation. [4]
 c) Explain valid and invalid use of tail extrapolation. [2]



Total No. of Questions: 8]

SEAT No. :

PA-717

[5928]-173

[Total No. of Pages :2

**M.E. (E & TC) (Communication Networks)
HIGH SPEED COMMUNICATION NETWORKS
(2017 Pattern)(Semester-I) (504502)**

Time : 3 Hours]

[Max. Marks : 50

Instructions to the candidates:

- 1) *Answer any 5 Questions out of 8.*
- 2) *Neat diagrams must be drawn wherever necessary.*
- 3) *Figures to the right indicate full marks.*
- 4) *All questions carry equal marks.*

Q1) a) Give two applications of wireless LANs and explain why wireless LANs would be appropriate for these applications. **[5]**

b) How does Frame Relay function? Explain with an application. **[5]**

Q2) a) How does streaming protocol work? What are different streaming protocols? Explain any one in detail. **[5]**

b) Describe various ISA components and services. **[5]**

Q3) a) Why is video filtering is needed? Explain working principle of video filtering? **[6]**

b) Explain H. 264/AVC coder **[4]**

Q4) a) How does Cell Delay variation relate to performance of Congestion control in ATM networks? **[5]**

b) How does streaming protocol work? What are different streaming protocols? Explain any one in detail. **[5]**

Q5) a) Explain any two Dynamic Protocols. **[6]**

b) Explain Frame Relay network with an example of its application. **[4]**

P.T.O.

- Q6)** a) Discuss two ATM protocols. [5]
b) What is the need of Wireless LANs? Explain with an example. [5]
- Q7)** a) Explain the working with architecture of 802.11. [6]
b) Describe with diagram the connection of ATM in ATM cell. [4]
- Q8)** a) How is Congestion control achieved in Frame Relay? [5]
b) Discuss and compare various mechanisms of congestion control. [5]



Total No. of Questions: 8]

SEAT No. :

PA-718

[5928]-174

[Total No. of Pages :1

M.E. (Electronics & Telecommunication) (Communication Network)

NETWORK SECURITY

(2017 Pattern) (504503) (Semester - I)

Time : 3 Hours]

[Max. Marks : 50

Instructions to the candidates:

- 1) *Attempt any five questions out of eight questions.*
- 2) *Assume suitable data, wherever necessary.*
- 3) *Right hand side number indicate marks.*

- Q1)** a) Explain in detail Information Security concept? [5]
b) Explain in detail Intrusion detection? [5]
- Q2)** a) Explain conventional encryption. [5]
b) Explain security architecture? [5]
- Q3)** a) Explain cipher block? [5]
b) Explain operating system security management? [5]
- Q4)** a) Explain RSA algorithm? [5]
b) Explain Network security models? [5]
- Q5)** a) Explain Network security applications? [5]
b) Explain Cybersecurity? [5]
- Q6)** a) Explain SMIME IP security? [5]
b) Explain Incident handling with cyber security? [5]
- Q7)** a) Explain TSL in detail? [5]
b) Explain Cybersecurity for Bluetooth Data communication? [5]
- Q8)** a) Explain SSL? [5]
b) Explain need of cybersecurity for online shopping? [5]



Total No. of Questions : 8]

SEAT No. :

PA-719

[Total No. of Pages : 2

[5928]-175

M.E (E&TC) (Communication Network)

TRAFFIC ANALYSIS AND QOS

(2017 Pattern) (Semester - II) (504507)

Time : 3 Hours]

[Max. Marks : 50

Instructions to the candidates:

- 1) *Answer Q.No. 1 or 2, Q3 or 4, Q5 or Q6, Q7 or Q8.*
- 2) *Figures to the right indicate full marks.*
- 3) *Assume suitable data, if necessary.*
- 4) *Use of electronic pocket calculator is allowed.*

- Q1)** a) Explain OSI network management model in detail. [6]
b) What is organization model? Explain 2 tier & 3 tier network management organization model in detail. [6]

OR

- Q2)** a) What are different message PDUs used in SNMP operation. Explain the encapsulation in detail. Write a note on Trap PDU with a suitable diagram showing different fields. [6]
b) What are the requirements of 3 tier NMS? [6]

- Q3)** a) Explain the conceptual Model of Telecommunication Management. [7]
b) Describe in detail Optical network & MAN feeder network. [6]

OR

- Q4)** a) Write a note on Broadband Network Management. [7]
b) Write a short note on Multi Protocol Label switching [6]

P.T.O.

- Q5)** a) Explain the utility & application area of high speed LANs. [6]
b) Explain 802.5 token Ring Technology in High Speed LANs. [6]

OR

- Q6)** a) What are the two types of QoS solutions? Explain in brief. [6]
b) What are the types of Network Traffic? Explain in brief. [6]

- Q7)** a) Write a short note on MPLS traffic Engineering. [7]
b) What are function provided by ISA to manage congestion & QoS transport? [6]

OR

- Q8)** a) What is the difference between flow control and Error Control? [7]
b) Describe Traffic Control and Congestion Control in ATM Networks [6]



Total No. of Questions : 8]

SEAT No. :

PA-720

[Total No. of Pages : 2

[5928]-176

M.E. (E & TC) (Communication Networks)
BROADBAND WIRELESS TECHNOLOGIES
(2017 Credit Pattern) (Semester - II) (504508)

Time : 3 Hours]

[Max. Marks : 50

Instructions to the candidates:

- 1) *Answer any five questions.*
- 2) *Neat diagrams must be drawn wherever necessary.*
- 3) *Figures to the right candidates indicate full marks.*

- Q1)** a) Explain the architecture of orthogonal FDMA in detail? [5]
b) Explain the advantages of CP based CDMA over single carrier FDMA. [5]
- Q2)** a) What is the difference between multi antenna system and MIMO? [5]
b) Discuss in detail about SVD based Eigen beamforming technique. [5]
- Q3)** a) Compare Time hopping, frequency hopping with direct sequence in ultrawideband system. [5]
b) Discuss the difference between ALOHA and slotted Aloha protocols in Media Access control. [5]
- Q4)** a) Explain Carrier sense multiple access with collision avoidance MAC in detail. [5]
b) Discuss the IEEE 802.11 MAC protocol with suitable diagrams. [5]

P.T.O.

- Q5)** a) Classify the Routing Protocols in Wireless Broadband Networks with suitable examples. [5]
- b) Explain the significance of outage probability for video services in a multirate DS-CDMA system. [5]
- Q6)** a) What are the two types of connections supported by WiMAX? [5]
- b) Explain Dynamic BW allocation algorithm (DBA) in WiMAX? [5]
- Q7)** a) Explain the architecture of Ethernet Passive Optical Networks (EPONS) in detail. [5]
- b) Explain the difference between passive and active optical network. [5]
- Q8)** Write a short note on (any two) :
- a) Hybrid WOBAN [5]
- b) Fault tolerance & self-healing [5]
- c) Scalable broadband access networks [5]



Total No. of Questions : 8]

SEAT No. :

PA-721

[Total No. of Pages : 2

[5928]-177

M.E (E&TC) (Communication Network)

SDR AND COGNITIVE RADIO

(2017 Pattern) (Semester - II) (504509)

Time : 3 Hours]

[Max. Marks : 50

Instructions to the candidates:

- 1) *Answer Q.No. 1 or 2, Q3 or 4, Q5 or Q6, Q7 or Q8.*
- 2) *Neat diagrams to be drawn wherever necessary.*
- 3) *Figures to the right indicate full marks.*
- 4) *Use of calculator is allowed.*
- 5) *Assume suitable data if necessary.*

- Q1)** a) Give an overview of Cognitive Radio concept. [7]
b) Explain two major applications where Cognitive Radio technology is being used. [6]
- Q2)** a) Describe various low cost Cognitive Radio platforms available. [7]
b) What is the future scope of Software Defined Radio? [6]
- Q3)** a) Give an account on various worldwide frequency plans available. [6]
b) Give an overview of Cognitive Radio Architecture. [6]
- Q4)** a) Write on different layer wise architecture of Cognitive Radio. [6]
b) How is end to end communication accomplished in the case of Cognitive Radio? [6]
- Q5)** a) Write short note on Real Time Operating Systems. [6]
b) What are the requirements of CORBA?. [6]

P.T.O.

- Q6)** a) Give an account of functional overview of SCA. [6]
b) Explain the compliance between SCA and JTRS. [6]
- Q7)** a) How are adaptive techniques applied to antennas? [7]
b) Describe in detail smart antenna architecture. [6]
- Q8)** a) How is cognitive radio system principles applied to smart antenna systems? [7]
b) Give an account of Radio Frequency design. [6]



Total No. of Questions : 8]

SEAT No. :

PA-2677

[Total No. of Pages : 2

[5928]-178
M.E. (E & TC)
4G - LTE : CELLULAR SYSTEMS
(2017 Pattern) (Semester - III) (604501)

Time : 3 Hours]

[Max. Marks : 50

Instructions to the candidates:

- 1) *Solve Q.1 or Q.2, Q.3 or Q.4, Q.5 or Q.6, Q.7 or Q.8.*
- 2) *Neat diagrams to be drawn wherever necessary.*
- 3) *Figures to the right indicate full marks.*
- 4) *Use of calculator is allowed.*
- 5) *Assume suitable data, if necessary.*

Q1) a) Explain the evolution from 3G to 4G technologies. **[7]**

b) Write on system architecture evolution of LTE. **[6]**

OR

Q2) a) Describe in detail Packet Data Convergence Protocol in LTE. **[7]**

b) Explain how serving gateway and packet data network gateway play a role in LTE. **[6]**

Q3) a) Detail the RF requirements for LTE. **[7]**

b) How is carrier aggregation accomplished in LTE. **[6]**

OR

Q4) a) Describe in detail the trans receiver design in spectrum sharing. **[7]**

b) Illustrate the methodology involved in resource management. **[6]**

Q5) a) Explain the key features of OFDMA. **[6]**

b) Describe the working of Software Defined Radio. **[6]**

OR

P.T.O.

- Q6)** a) What are LTE advanced main MIMO modes? [6]
b) Discuss downlink and uplink MIMO transmission. [6]

- Q7)** a) Write in detail on mixed architectures of CoMP. [6]
b) Discuss the backhaul design for inband relaying. [6]

OR

- Q8)** a) Give the point of differences between LTE and Wi-Max. [6]
b) Write short notes on Wi-Max deployment. [6]



Total No. of Questions : 8]

SEAT No. :

PA-722

[Total No. of Pages : 2

[5928]-179

**M.E. (Electronics & Telecommunication) (Communication
Networks)**

**MODERN COMMUNICATION RECEIVER DESIGN AND
TECHNOLOGY**

(2017 Credit Pattern) (Semester - III) (604502)

Time : 3 Hours]

[Max. Marks : 50

Instructions to the candidates:

- 1) *Attempt any 5 questions out of 8.*
- 2) *Neat diagrams must be drawn whenever necessary.*
- 3) *Figures to the right indicates full marks.*
- 4) *Assume suitable data, if necessary.*

Q1) a) With the help of suitable block diagram, explain the implementation of double conversion receiver. [5]

b) Explain the weaver architecture of image reject mixer. [5]

Q2) a) Explain the intermodulation spurious system analysis for the star - 10 double, general coverage receiver. [5]

b) With the help of suitable block diagram, explain the implementation of special conversion receiver. [5]

Q3) a) Explain the design of automatically switched half-octave filter banks for HF transceiver. [5]

b) Explain the switching mechanisms of front-end filters for best dynamic range performance. [5]

Q4) a) Explain the system composite noise figure with block diagram. [5]

b) Explain the half-octave filter banks used for ultrawideband microwave receiver. [5]

Q5) a) Explain the Gilbert Cell mixers with suitable diagram. [5]

b) Explain the conversion loss and noise figure of diode mixers. [5]

P.T.O.

- Q6)** a) Explain the brute force synthesizer using harmonic generator and mixer synthesis method. [5]
b) Compare the direct and indirect methods of non brute force synthesizer. [5]
- Q7)** a) With a suitable Block diagram explain the fast attack, slow release AGC system in the Star - 10 IF receiver. [5]
b) Explain the AD 8361 precision RMS detector used in 500MHz AGC system. [5]
- Q8)** a) What are design considerations for Audio and Baseband Amplifier of receiver? [5]
b) Enlist different Noise Blanker & state the importance of Noise Blanker in IF receiver. [5]



Total No. of Questions : 08]

SEAT No. :

PA-594

[Total No. of Pages : 2

[5928]-18

**M.E. (Civil) (Environmental Engineering)
RESEARCH METHODOLOGY
(2017 Pattern) (Semester - III) (601074)**

Time : 3 Hours]

[Max. Marks : 50

Instructions to the candidates:

- 1) *Attempt Q1 or Q2, Q3 or Q4, Q5 or Q6 and Q7 or Q8.*
- 2) *Neat diagram must be drawn wherever necessary.*
- 3) *Figures to the right indicate full marks.*
- 4) *Assume suitable data, if necessary.*

- Q1)** a) State the elements and objectives of literature survey. [5]
b) Enlist at least four different research funding agencies. Explain details about any one. [4]

OR

- Q2)** a) Discuss the errors in selecting a research problem. [5]
b) Explain the importance of review of literature, different sources of literature. [4]

- Q3)** a) What is meaning & significance of attitude measurement and scaling?[5]
b) Enlist the important parametric tests for Hypothesis testing & Explain any one in detail. [4]

OR

- Q4)** a) What are factors affecting “Selection of appropriate data collection method”? [5]
b) Discuss the criteria of good measurements. [4]

- Q5)** a) Explain Descriptive and inferential statistics. [8]
b) Write a note on discriminant and cluster analysis. [8]

OR

P.T.O.

- Q6)** a) What is Multi-dimensional Scaling? Explain metric & non- metric approach of MDS & also explain significance of MDS. [8]
- b) What is correlation and regression analysis? What are their methods'? State its significance with their values? [8]

- Q7)** a) Explain the significance of a research report writing and narrate the various steps involved in writing such a report. [7]
- b) Write a note on "Plagiarism" in research. [5]
- c) Discuss the procedure for obtaining a patent. [4]

OR

- Q8)** a) What are different types of reports? Describe the formulation of report. [7]
- b) Discuss the steps involved in publishing a research idea in a Journal. [5]
- c) Explain the different factors to be considered for effective presenting a research. [4]



Total No. of Questions : 8]

SEAT No. :

PA-723

[Total No. of Pages : 2

[5928]-188

M.E (E&TC) (Microwave)

ELECTROMAGNETICS AND ANTENNA THEORY

(2017 Pattern) (Semester - I) (504301)

Time : 3 Hours]

[Max. Marks : 50

Instructions to the candidates:

- 1) Answer any five questions.
- 2) Neat diagrams must to be drawn wherever necessary.
- 3) Figures to the right indicate full marks.
- 4) Use of calculator is allowed.
- 5) Assume suitable data if necessary.

Q1) a) Why the spiral antenna is broadband antenna? [5]
b) Betemine the length of the dipole whose input resistance is 50 ohms.(194) [5]

Q2) a) A spherical reflector has a 10-ft diameter. If at 11.2 GHZ the maximum allowable phase error is $\lambda/16$, find the maximum permissible aperture.[6]
b) Explain the Equivalence principle and illustrate its applications in aperture antenna analysis with a suitable example. [4]

Q3) Describe the following antennas with illustrative structural diagrams, radiation pattern, features [10]

- a) Corner reflector and Parabolic Reflector
- b) H-Plane pyramidal and conical horn antenna

Q4) A rectangular aperture with a constant field distribution, with $a = 3\lambda$ and $b = 2\lambda$, is mounted on an infinite ground plan, Compute the, [10]

- a) FNBW in the E-plane
- b) HPBW in the E-plane
- c) FSLBW in the E-plane
- d) FSLMM in the E-plane
- e) directivity (675)

P.T.O.

- Q5)** a) Give the comparison of various radiating elements such as infinitesimal dipole, small dipole, finite length dipole and half wave length dipole. [6]
b) Explain the salient features of lens antenna and explain the working principle with relevant diagram. [4]
- Q6)** a) What is array factor? Derive the expression for the array factor of an N-element uniform linear array. [5]
b) Give the structural features and radiation characteristics of following antennas: [5]
i. Rhombic Antenna
ii. Long Wire Antenna
- Q7)** a) Design an rectangular microstrip antenna using a substrate(RT/Duroid 5880) with dielectric constant of 2.2, $h=0.15$ so as to resonate at 10GHz.(820) [6]
b) Explain the following method of analysis in Microstrip patch antenna
i)Transmission-Line Model. [4]
- Q8)** a) With reference to uniform plan wave explain the following parameters: Reflection Coefficient ,VSWR. [4]
b) Derive an expression for boundary conditions for boundary between two different magnetic materials. [6]



Total No. of Questions : 12]

SEAT No. :

PA-595

[Total No. of Pages : 2

[5928]-19

M.E. (Civil) (Geotechnical Engineering)

ADVANCE SOIL MECHANICS

(2017 Course) (Semester - I) (501121)

Time : 3 Hours]

[Max. Marks : 50

Instructions to the candidates:

- 1) *Answer Q.1 or Q.2, Q.3 or Q.4, Q.5 or Q.6, Q.7 or Q.8, Q.9 or Q.10 and Q.11 or Q.12.*
- 2) *Neat diagrams must be drawn wherever necessary.*
- 3) *Figures to the right indicate full marks.*
- 4) *Assume suitable data, if necessary and mention it clearly.*
- 5) *Use of non-programmable calculator is allowed.*

Q1) State and explain stress invariants. With the help of Mohr circle explain the two types of stress invariants. **[4]**

- a) Mean normal stress and
- b) Deviatoric stress

OR

Q2) Write a short note on soil bodies exhibiting non-homogeneous properties. **[4]**

Q3) What is stress path? Explain stress path for the cases **[4]**

- a) Effective stress path
- b) Total stress path

OR

Q4) Which parameters affect the yielding and failure in soil? Describe in detail. **[4]**

Q5) Briefly explain at-rest earth pressure, active earth pressure and passive earth pressure with suitable diagrams. **[4]**

OR

Q6) Describe stability of retaining wall against overturning, sliding and bearing capacity failure. **[4]**

P.T.O.

Q7) Explain how three dimensional consolidation takes place by the construction of sand drains? Also, explain its design considerations. [4]

OR

Q8) Enlist the effects of smear zone on radial consolidation. [4]

Q9) a) Explain an elastic-soil-spring method of vibration for analysis of foundations. Also, state the assumptions made in the theory. [6]

b) Describe the general design criterias for the machine foundations. [6]

c) Write a note on “Dynamic loads due to vibrating machines”. [4]

OR

Q10)a) Explain linear elastic weightless spring method. [6]

b) What are the general requirements of machine foundations? [6]

c) Explain the difference between the following vibration sources. [4]

i) Reciprocating machine

ii) Forge hammer

iii) Earthquake

Q11)a) Describe the design criterias for foundation of rotary machine. [6]

b) Explain two dimensional Combined method for the design of foundations of rotary machines. [6]

c) Why vibration isolation is required? Describe the methods of vibration control? [6]

OR

Q12)a) Explain “use of isolators method” in vibration isolation with neat sketches. [6]

b) What are the properties of good vibrating isolation material? [6]

c) Write a note on: [6]

i) Importance of vibration isolation

ii) Rotary type machines



Total No. of Questions : 6]

SEAT No. :

PA-725

[Total No. of Pages : 1

[5928]-190

M.E. (E&TC) (Microwave)

MICROWAVE MEASUREMENTS

(2017 Pattern) (Semester - I) (504303)

Time : 3 Hours]

[Max. Marks : 50

Instructions to the candidates:

- 1) Attempt any five questions.
- 2) Figures to the right indicate full marks..
- 3) Assume suitable data, if necessary.

- Q1)** a) State the basic principles of Transmission Lines. [5]
b) What are the sources of uncertainty in RF and microwave measurement? [5]
- Q2)** a) What is the need and important factor of attenuation measurement? [5]
b) Define Noise. State and explain different types of noise. [5]
- Q3)** a) Explain the basic working principle of Spectrum Analyzer with diagram. [5]
b) Explain the method of calibration of Automatic Network analyzers. [5]
- Q4)** a) State and explain applications of Spectrum Analyzer. [5]
b) Compare Spectrum Analyzer and Network Analyzer. [5]
- Q5)** a) Explain different MMIC measurement techniques. [5]
b) State and explain RF power measurements and calibration. [5]
- Q6)** Write short notes on :
a) Power Splitter. [5]
b) Reflectometer. [5]



Total No. of Questions : 6]

SEAT No. :

PA-726

[Total No. of Pages : 2

[5928]-191

M.E. (E & TC) (Microwave)

COMPUTATIONAL ELECTROMAGNETICS

(2017 Pattern) (Semester - II) (504307)

Time : 3 Hours]

[Max. Marks : 50

Instructions to the candidates:

- 1) *Answer any five questions.*
- 2) *Neat diagram must be drawn wherever necessary.*
- 3) *Use of electronics pocket calculator is allowed.*
- 4) *Assume suitable data if necessary.*
- 5) *Figures to the right indicate full marks.*

Q1) a) State the different errors in numerical solution and explain how they affect the accuracy and stability of FD solution. [5]

b) Explain in detail how the finite difference analysis is carried out for guided structures. [5]

Q2) a) Derive the Green's function corresponding to PDE for free space. [4]

b) Explain the strengths and weakness of FDM and FDDTD modeling. [4]

c) What is method of moments. [2]

Q3) a) What is variational method of analysis, explain it with a relevant example. [6]

b) What are the applications of Ritz variational method. [4]

Q4) What is functional? If a functional is defined as $F[y(x)] = \int_0^1 y(x) dx$, then what is the functional for $y(x) = 1$, $y(x) = x$, $y(x) = x^2$. [10]

P.T.O.

Q5) Explain Yee's Algorithm with an illustrative Flow chart with suitable example. **[10]**

Q6) Explain the various steps involved in Method of Moments with illustrative diagrams and examples. **[10]**



Total No. of Questions : 6]

SEAT No. :

PA-727

[Total No. of Pages : 1

[5928]-192

**M.E. (E & TC) (Microwave)
RF AND MMIC TECHNOLOGY
(2017 Pattern) (Semester - II) (504308)**

Time : 3 Hours]

[Max. Marks : 50

Instructions to the candidates:

- 1) *Answer any five questions.*
- 2) *Neat diagrams must be drawn wherever necessary.*
- 3) *Use of electronics pocket Calculator is allowed.*
- 4) *Assume Suitable data if necessary*
- 5) *Figures to the right indicates full marks.*

- Q1)** a) Explain performance issues of MMIC technology. [6]
b) Write a note on multi chip module technology [4]
- Q2)** a) Explain fabrication technology used for design of HEMT device. [6]
b) Explain the structure of micro strip coupler. [4]
- Q3)** a) Explain multilayer technique used in MMIC. [5]
b) What is difference between Micro strip couplers and splitters. [5]
- Q4)** a) Explain synthesis process of n port network. [5]
b) Explain network matrix decomposition. [5]
- Q5)** a) Explain harmonic balance method used in microwave circuit. [6]
b) What are the features and applications of CAD package. [4]
- Q6)** a) How digital modulator is designed by MMIC technology? Explain. [6]
b) Explain MMIC test system. How MMIC Measurement is carried out?[4]



Total No. of Questions : 8]

SEAT No. :

PA-728

[Total No. of Pages : 2

[5928]-193

M.E. (E & TC) (Microwave)

WIRELESS COMMUNICATION SYSTEM

(2017 Pattern) (Semester - II) (504309)

Time : 3 Hours]

[Max. Marks : 50

Instructions to the candidates:

- 1) Answer any five questions.
- 2) Neat diagrams must be drawn wherever necessary.
- 3) Figures to the right side indicate full marks.
- 4) Use of calculator is allowed.
- 5) Assume Suitable data if necessary.

Q1) a) Compare and contrast all multiple access techniques. [5]

b) What is the need for frequency reuse? Prove that for a hexagonal geometry. the co-channel reuse factor is $q = \sqrt{3}N$, where $N = i^2 + ij + j^2$. [5]

Q2) a) Write short note on Beyond 3G. [5]

b) Explain the hexagonal cell arrangement with reuse factor, cluster size and reuse ration to achieve the optimal co-channel interference. [5]

Q3) a) What is probability model that describes the smooth traffic and write the distribution and explain in detail. [5]

b) Explain co-channel interference ratio and its reduction. [5]

Q4) a) Explain the Indoor path—loss model and Link Margin. [5]

b) If 10W is applied to a unit gain antenna with a 1800MHz carrier frequency, find the received power in dBm at a free-space distance 500 m from the antenna receiver and free- space path loss if P_r at 2 Km. [5]

P.T.O.

- Q5)** a) Define the following terms : **[5]**
- i) Quality of service
 - ii) Blocking probability
 - iii) Grade of Service
 - iv) Per Count
 - v) Blocked Call Held (BCH)
- b) Explain the CDMA system architecture. **[5]**
- Q6)** a) Explain the GSM architecture. **[5]**
- b) Write short note on GSM logical channels. **[5]**
- Q7)** a) Explain the Radio Link Control protocol in UMTS. **[5]**
- b) What is hand off mechanisms? Discuss Hard and Soft handoff mechanisms. **[5]**
- Q8)** a) What are the UMTs system features? Draw the UMTS network architecture. **[5]**
- b) Explain the protocol stack in Universal Mobile Telecommunications System. **[5]**



Total No. of Questions : 6]

SEAT No. :

PA-729

[Total No. of Pages : 2

[5928]-194

M.E. (E & TC) (Microwave)

EMI AND EMC TECHNIQUES

(2017 Pattern) (Semester - III) (604301)

Time : 3 Hours]

[Max. Marks : 50

Instructions to the candidates:

- 1) *Answer any five questions.*
- 2) *Neat diagrams must be drawn wherever necessary.*
- 3) *Use of electronics pocket calculator is allowed.*
- 4) *Figures to the right side indicate full marks.*
- 5) *Assume Suitable data if necessary.*

- Q1)** a) Explain in detail intersystem EMI and intra system EMI. [4]
b) Explain the difference between grounding and shielding. [4]
c) What are different sources of EMI? [2]
- Q2)** a) How to minimize EMI during design of RF transmitter and receiver system? [4]
b) Which parameters are considered for antenna EMI prediction. [4]
c) List different types of EMI Suppression techniques. [2]
- Q3)** a) What is amplitude culling and Frequency culling with respect to transmitter and receiver circuit? [4]
b) Give the difference between radiated and conducted EMI. [4]
c) What is radiation susceptibility? [2]
- Q4)** a) Compare Five different approaches for measurement of radiated emission (RE) and radiation susceptibility (RS) of an equipment. [5]
b) Explain the design steps of common mode and differential mode filter. [5]

P.T.O.

- Q5)** a) List the Military and industrial EMI standards. [5]
b) Explain low pass EMI filter with its characteristics. [5]
- Q6)** a) Explain design parameters of micro strip band pass filter. [5]
b) Write short note on lumped element type low pass filter. [5]



Total No. of Questions : 8]

SEAT No. :

PA-730

[Total No. of Pages : 2

[5928]-195
M.E. (E & TC) (Microwave)
RADAR AND SATELLITE COMMUNICATIONS
(2017 Pattern) (Semester - III) (604302)

Time : 3 Hours]

[Max. Marks : 50

Instructions to the candidates:

- 1) *Attempt any 5 questions.*
- 2) *Neat diagrams must be drawn whenever necessary.*
- 3) *Figures to the right indicate full marks.*
- 4) *Use of logarithmic tables slide rule, Mollier charts, electronic pocket calculator and steam tables is allowed.*
- 5) *Assume suitable data, if necessary.*

Q1) a) State the different methods for RCS estimation. Explain any one in detail. **[5]**

b) Define the Doppler effect and explain the CW radar with its limitations. **[5]**

Q2) a) With the help of block diagram explain the concept of radar. **[5]**

b) How the basic radar equation can be manipulated for an application of volume search? **[5]**

Q3) a) Explain the scanning and lobing of antennas in tracking radar. **[5]**

b) Describe the antenna beam shapes for different types of radars. **[5]**

Q4) a) Explain the terms related to radar **[5]**

i) Unambiguous range

ii) Clutters

b) Write short note on weather prediction radar system. **[5]**

Q5) a) Compare LEO, MEO and GEO. **[5]**

b) Write short note on types of satellite as per altitude. **[5]**

P.T.O.

- Q6)** a) Explain the elevation and inclination angles along with their significance. [5]
b) Describe the launching steps of artificial satellite. [5]
- Q7)** a) Explain the various losses in uplink and downlink design of satellite. [5]
b) Explain AOC system and its importance in satellite communication. [5]
- Q8)** a) Describe the visibility test of satellite. [5]
b) Compare FDMA and CDMA technique used in satellite communication with respect to their parameters and performance characteristics. [5]



Total No. of Questions : 8]

SEAT No. :

PA-731

[Total No. of Pages : 3

[5928]-196

M.E (E&TC) (Signal Processing)

MATHEMATICS FOR SIGNAL PROCESSING

(2017 Pattern) (Semester - I) (504401)

Time : 3 Hours]

[Max. Marks : 50

Instructions to the candidates:

- 1) All questions are compulsory.
- 2) Assume suitable data if necessary.
- 3) Use of Non-programmable calculator is allowed.

Q1) a) Prove That : [6]

$$[B \times C, C \times A, A \times B] = [ABC]^2$$

$$A \times \{B \times (C \times D)\} = B.D (A \times C) - B.C (A \times D)$$

b) Prove that formula : [6]

$$(B \times C). (A \times D) + (C \times A). (B \times D) + (A \times B). (C \times D) = 0$$

$$\text{And hence show that } \sin (C + \Phi) \sin (\theta - \Phi) = \sin^2 \theta - \sin^2 \Phi$$

OR

Q2) a) Find the moment about a line through the origin having direction $2i + 2j + k$ due to a 30 kg force acting at a point $(-4, 2, 5)$ in the direction of $12i - 4j - 3k$. [6]

b) Prove that : [6]

$$\sin (A+B) = \sin A \cos B + \cos A \sin B$$

$$\cos (A+B) = \cos A \cos B - \sin A \sin B$$

P.T.O.

Q3) a) Determine the rank of the following matrices: [6]

$$\begin{bmatrix} 1 & 2 & 3 \\ 1 & 4 & 2 \\ 2 & 6 & 5 \end{bmatrix}$$

$$\begin{bmatrix} 0 & 1 & -3 & -1 \\ 1 & 0 & 1 & 1 \\ 3 & 1 & 0 & 2 \\ 1 & 1 & -2 & 0 \end{bmatrix}$$

b) Use Gauss - Jordan method to find the inverse of the matrix : [7]

$$\begin{bmatrix} 1 & 1 & 3 \\ 1 & 3 & -3 \\ -2 & -4 & -4 \end{bmatrix}$$

OR

Q4) a) Reduce the matrix to its normal form and hence find its rank : [6]

$$\begin{bmatrix} 2 & 3 & -1 & -1 \\ 1 & -1 & -2 & -4 \\ 3 & 1 & 3 & -2 \\ 6 & 3 & 0 & -7 \end{bmatrix}$$

b) If A & C are non-singular matrices then show that : [7]

$$\begin{bmatrix} A & 0 \\ B & C \end{bmatrix}^{-1} = \begin{bmatrix} A^{-1} & 0 \\ -C^{-1}BA^{-1} & C^{-1} \end{bmatrix}$$

Hence find the inverse of :

$$\begin{bmatrix} 1 & 0 & 0 & 0 \\ 0 & 2 & 0 & 0 \\ 3 & 0 & 4 & 0 \\ 0 & 1 & 0 & 3 \end{bmatrix}$$

Q5) a) A coin is tossed up four times in succession, Determine the probability of obtaining three heads. [6]

b) Consider a random experiment consisting of drawing of two cards in succession from a deck of cards without replacing the first card drawn. Find the probability of obtaining two red aces in two draws. [6]

OR

Q6) a) A binary symmetric channel has a conditional probability of error $p = 10^{-5}$ and the messages m_0 and m_1 are generated at the source with equal probability. Determine : [6]

i) The probability of receiving a response of r_0

ii) The probability of receiving a response of r_1

iii) The probability that m_0 was sent and given that r_0 is received

iv) The probability that m_1 was sent and given that r_0 is received

b) The joint probability density of random variables X and Y is : [6]

$$F_{x,y} = 1/4 \exp(-|x| - |y|) :$$

for $-\infty < x < \infty, -\infty < y < \infty$.

Calculate the probability that :

$$X \leq 1 \text{ and } Y \leq 0$$

Q7) a) Explain Power Spectral Density (PSD). Also explain its various properties. [6]

b) A sinusoidal signal generator of deterministic frequency f_0 and amplitude A is switched on. The starting time is random such that $x(t) = A \sin(2\pi f_0 t + \Phi)$. Find the autocorrelation of the random process. Also sketch the same. [7]

OR

Q8) a) Consider a sinusoidal process X(t) denoted by : [6]
 $X(t) = A \cos(2\pi f_c t + \Phi)$; where A and f_c are constants and Φ is uniformly distributed random variable.

$$f_\phi(\theta) = \frac{1}{2\pi}, 0 \leq \theta \leq 2\pi$$

$$= 0, \text{ elsewhere}$$

Show that the random sinusoidal process is ergodic in both mean and autocorrelation function.

b) Discuss the transmission of random process through linear filters. [7]



- Q5)** a) Explain following loss less compression techniques in detail. [3]
i) Arithmetic coding [3]
ii) Bit plane coding [2]
b) With block diagram, explain JPEG compression model in detail. [5]
- Q6)** a) Explain Region merging & region splitting techniques. [5]
b) Explain Region representation using structure features and texture features. [5]
- Q7)** a) Explain different frames used in video representation in MPEG standard. [5]
b) Explain different color models used in Video compression. [5]



Total No. of Questions : 6]

SEAT No. :

PA-732

[Total No. of Pages : 2

[5928]-198

M.E. (E&TC) (Signal Processing)

ADVANCED DIGITAL SIGNAL PROCESSING

(2017 Pattern) (Semester - I) (504403)

Time : 3 Hours]

[Max. Marks : 50

Instructions to the candidates:

- 1) Answer any five questions.
- 2) Figures to the right indicate full marks.
- 3) Assume suitable data if necessary.
- 4) Use of Non-programmable calculator is allowed.

- Q1)** a) State the advantages and disadvantages of FIR and IIR filters. [4]
b) Compare Von-Neumann architecture and Harvard architecture. [4]
c) State what do you mean by Adaptive filters. [2]

- Q2)** a) Explain VLIW architecture in brief. [4]
b) Explain the concept of ergodic processes. [4]
c) What is the drawback in FIR filter design using Frequency Sampling method? How it is overcome? [2]

- Q3)** a) Define Discrete Fourier Transform. [2]

- b) Compute DFT of a finite length-N sequence defined for [4]

$$0 \leq n \leq N - 1$$

$$x(n) = \begin{cases} 1 & n = 0 \\ 0 & 1 \leq n \leq N - 1 \end{cases}$$

- c) Calculate the DFT of the following sequence $x(n)$. [4]

$$x(n) = \{1, 1, -2, -2\}$$

P.T.O.

- Q4)** a) Define downsampling process. Consider a discrete time signal $x(n) = \{1, 2, 3, 4, 5, 6, 7, 8, 9, 10, 11, 12\}$. Determine the downsampled version of the signals for sampling rate reduction factors [7]
- a) $D = 2$
 - b) $D = 3$
 - c) $D = 4$
- b) Define interpolation. State any two applications of multirate DSP. [3]
- Q5)** a) What are random signals? What is their use? [2]
- b) Draw & explain uniform and Gaussian Probability Density functions.[8]
- Q6)** a) Explain Von-Neumann architecture with the help of block diagram. [5]
- b) Compare Harvard architecture and Von-Neumann architecture. [5]



Total No. of Questions : 8]

SEAT No. :

PA-733

[Total No. of Pages : 2

[5928]-199

M.E. (E & TC) (Signal Processing)
BIOMEDICAL SIGNAL PROCESSING
(2017 Pattern) (Semester - II) (504407)

Time : 3 Hours]

[Max. Marks : 50

Instructions to the candidates:

- 1) *Answer any five questions.*
- 2) *Neat diagrams must be drawn wherever necessary.*
- 3) *Figures to the right side indicate full marks.*
- 4) *Assume Suitable data if necessary.*

Q1) a) Explain cell junction with the help of diagram. [5]

b) Explain Heart Structure with diagram. [5]

Q2) a) How to use Eigen analysis for bio-signals processing. State its advantages and limitations. [5]

b) Explain Electrical Activity of heart with diagram. [5]

Q3) a) Write note on different Medical Images. [4]

b) Write a note on CT scan. [6]

Q4) a) What is the purpose of PET scanning? [4]

b) With the sequence of events and waves explain cardiac cycle and draw PQRST waveform. [6]

Q5) a) Write a note on MRI and Functional MRI(FMRI). [4]

b) Write a note on Eigen Analysis Spectral Analysis. [4]

c) List Time frequency Methods in processing of Bio-signals. [2]

P.T.O.

- Q6)** a) Explain Radon Transform, Inverse Radon Transform. [4]
b) Explain in detail electromechanical models of signal generation. [4]
c) List any two characteristics of Noise. [2]
- Q7)** a) Define following : [4]
i) Edge
ii) Line
iii) Points
iv) Corners
b) Explain Spectral Analysis of Heart rate. [4]
c) Write a note on volumetric representation. [2]
- Q8)** a) Explain Noise reduction by Ensemble Averaging. [4]
b) Write a short note on RLS and Lattice Filter. [4]
c) List parametric system modelling. [2]



Total No. of Questions : 8]

SEAT No. :

PA-579

[Total No. of Pages : 2

[5928]-2

M.E. (Civil - Construction & Management)
MANAGEMENT AND PROJECT PLANNING IN CONSTRUCTION
(2017 Credit Course) (501022)(Semester-I)

Time : 3 Hours]

[Max. Marks : 50

Instructions to the candidates:

- 1) *Attempt Q.1 or Q.2, Q.3 or Q.4, Q.5 or Q.6 and Q.7 or Q.8.*
- 2) *Neat diagrams must be drawn wherever necessary.*
- 3) *Figures to the right indicate full marks.*
- 4) *Assume suitable data, if necessary and clearly state.*
- 5) *Use of cell phone is prohibited in the examination hall.*
- 6) *Use of electronic pocket calculator is allowed.*

Q1) a) Draw the Project Life Cycle of any construction project and discuss each stage in detail. **[4]**

b) Discuss the advantages and limitations of Line of Balance Method over Critical Path Method. **[5]**

OR

Q2) a) Explain the project clearance procedure for a dam construction. **[3]**

b) Explain the matrix structure of Organization with its advantages and applications. **[6]**

Q3) a) Solve the following problem and state the critical path and total duration of the project. **[5]**

Name of activity	Preceding activity	Duration (days)
A	---	8
B	---	7
C	B	10
D	A,C	12
E	B	9
F	C	6
G	C,E	8

b) What are the applications of work-study in civil engineering? **[4]**

OR

P.T.O.

- Q4)** a) For the example given in que. 3 (a) above, review of site was taken 10 days after start of the project. Following observations were noted. [6]
- i) Activity A will require 5 days more to finish.
 - ii) Activity B is complete
 - iii) Activity C will require 2 more days to complete and activity E will require 7 more days to complete.
 - iv) Activities D, F and G are not started yet.

Update the CPM network and present the revised critical path.

- b) Explain string diagram. What are its applications? [3]
- Q5)** a) Describe how safety of record keeping is achieved on site. [8]
- b) Write safety procedure for a welder on site. [8]

OR

- Q6)** a) Explain in brief : Workman Compensation Act. [8]
- b) What are the direct and indirect costs in an accident? [8]

- Q7)** a) What are the advantages and disadvantages of Merit Rating? [8]
- b) Write a short note on:
 - i) Artificial Neural Network [4]
 - ii) BIM in construction [4]

OR

- Q8)** a) Explain Fuzzy logic technique in brief and their application in construction. [8]
- b) Write a short note on:
 - i) Genetic algorithm [4]
 - ii) Incentives - Advantages and disadvantages [4]



Total No. of Questions : 8]

SEAT No. :

PA-596

[Total No. of Pages : 2

[5928]-20

M.E. (Civil) (Geotechnical Engineering)
GROUND IMPROVEMENT TECHNIQUES
(2017 Credit Pattern) (Semester-I) (501122)

Time : 3 Hours]

[Max. Marks : 50

Instructions to the candidates:

- 1) *Attempt Q.1 or Q.2, Q.3 or Q.4, Q.5 or Q.6 or Q.7 or Q.8.*
- 2) *Neat diagrams must be drawn wherever necessary.*
- 3) *Figures to the right indicate full marks.*
- 4) *Assume suitable data, if necessary and clearly state.*
- 5) *Use of cell phone is prohibited in the examination hall.*
- 6) *Use of electronic pocket calculator is allowed.*

- Q1)** a) State the characteristics of clay minerals for its identification. [4]
b) Discuss the engineering properties and behaviour of chemically stabilised soils. [5]

OR

- Q2)** a) Describe Electrical Effects in clay minerals. [5]
b) Which are the different methods of soil stabilization? [4]

- Q3)** a) How is the effectiveness of lime stabilization determined? [4]
b) State criteria for design of stone columns. [5]

OR

- Q4)** a) Explain laboratory testing of cement stabilised soil. [5]
b) How is dynamic consolidation carried out? [4]

- Q5)** a) Write short notes on: [8]
i) Sand drains
ii) Granular trench stabilisation
b) Describe the procedure to determine the bearing capacity of lime group. [8]

OR

P.T.O.

- Q6)** a) Discuss the design criteria for lime column foundations. [8]
b) What are lime columns and describe its applications? [8]

- Q7)** a) Explain permeation and hydro fracture grouting. [8]
b) How is grout injection measurement and monitoring carried out? [8]

OR

- Q8)** a) Explain the various grouting equipment with sketches. [8]
b) Write note on the types of grouting techniques (any two) [8]



Total No. of Questions : 8]

SEAT No. :

PA-1149

[Total No. of Pages : 2

[5928]-200

M.E. (E & TC) (Signal Processing)

SPEECH PROCESSING

(2017 Pattern) (Semester -II) (504408)

Time : 3 Hours]

[Max. Marks : 50

Instructions to the candidates:

- 1) *Answer any 5 questions.*
- 2) *Figures to the right indicate full marks.*
- 3) *Use of logarithmic tables is allowed.*
- 4) *Assume suitable data if necessary.*

- Q1)** a) Explain with block diagram the LTI model for speech signal and explain mathematical approach for same. [7]
b) Differentiate between pitch & formants. [3]
- Q2)** a) Explain with graphical representation for pitch frequency measurement using autocorrelation method. [5]
b) Explain with diagram parallel processing approach for the calculation of pitch frequency. [5]
- Q3)** a) Explain in detail spectrogram for speech signal. Mention its parameters. [5]
b) Explain Levinson-Durbin recursive algorithm for the calculation of prediction coefficients. [5]
- Q4)** a) Explain the pitch detection using LPC parameters in detail. [6]
b) Explain the homomorphic speech processing in detail. [4]
- Q5)** a) How to calculate Mel frequency coefficients of speech signal? Explain using block diagram. [5]
b) With the help of wavelet, how speech signal is analyzed? Explain it. [5]

P.T.O.

- Q6)** a) Define cepstrum. Explain how to calculate pitch & formants using cepstrum? [6]
b) Explain how speech signal is quantized & coding is carried out? [4]
- Q7)** a) List the uniform and non-uniform quantizers of speech signal? Explain any one non-uniform quantizer in detail. [6]
b) Write short note on. [4]
i) PCM.
ii) G-726.
- Q8)** a) Explain the echo cancellation application in detail. [5]
b) Explain the speech recognition in detail. [5]



Total No. of Questions : 8]

SEAT No. :

PA-734

[Total No. of Pages : 2

[5928]-201

M.E. (Electronics and Telecommunications) (Signal Processing)

COMPUTER VISION

(2017 Pattern) (Semester - II) (504409)

Time : 3 Hours]

[Max. Marks : 50

Instructions to the candidates:

- 1) *Attempt any five questions.*
- 2) *Figures to the right indicate full marks.*
- 3) *Neat diagrams must be drawn wherever necessary.*
- 4) *Make suitable assumptions wherever necessary.*

Q1) a) Explain the images produced by weak perspective projection. [5]

b) Draw and explain schematic diagram of digital camera. List any four specifications. [5]

Q2) a) Explain Basic 2D and 3D transformations. [5]

b) Write short note on challenges and applications of computer vision. [5]

Q3) a) Explain eight point algorithm in stereo vision for calibrated cameras. [4]

b) Explain co-relation based correspondence search in stereo images. [6]

Q4) a) Explain the process of Rectification in stereo vision. [4]

b) Explain simple stereo system and list stereo parameters. [6]

Q5) a) Explain RANSAC algorithm for model fitting in image analysis. [4]

b) Explain the concept fitting ellipse to image data. [4]

c) Define following image features : [2]

- i) Point &
- ii) Line

P.T.O.

- Q6)** a) Explain Hough transform for lines and curves. [4]
b) Explain with neat diagram image stitching. [4]
c) Define following image features : [2]
i) Corners &
ii) Edge
- Q7)** a) Write a short note on Kalman Filter. [4]
b) Explain motion based techniques for motion estimation. [4]
c) Define optical flow in images. [2]
- Q8)** a) What is brightness consistency in optical flow estimation? [4]
b) Explain differential based technique for motion estimation contaminated. [4]
c) List applications of Kalman Filter. [2]



Total No. of Questions : 8]

SEAT No. :

PA-735

[Total No. of Pages : 3

[5928]-202

M.E. (Electronics and Telecommunication) (Signal Processing)
STATISTICAL SIGNAL PROCESSING
(2017 Pattern) (Semester - III) (604401)

Time : 3 Hours]

[Max. Marks : 50

Instructions to the candidates:

- 1) *Attempt any five questions out of eight.*
- 2) *All Questions carry equal marks.*
- 3) *Figures to the right indicate full marks.*
- 4) *Make suitable assumptions wherever necessary.*

Q1) a) Explain Autoregressive moving average processes. **[5]**

b) In least Square Method parameters are defined in terms of nonlinear equations. Justify the statement. **[5]**

Q2) a) With the help of suitable block diagram explain Weiner filter application for Noise Cancellation. **[5]**

b) State and explain Levinson Durbin algorithm. **[5]**

Q3) a) Prove that Modified Periodogram is not a consistent estimate of power spectrum. **[5]**

b) What is Adaptive filtering? Explain with the help of block diagram and suitable Set of Equations. **[5]**

Q4) a) Explain filtering of Random Process. **[5]**

b) Discuss Properties and limitations of Pade's approximation technique. **[5]**

P.T.O.

Q5) a) Consider First order AR-Process that is generated by difference equation [4]

$$y(n) = ay(n-1) + w(n).$$

where $|a| < 1$ and $w(n)$ is zero mean white noise random process with variance σ_w^2

- i) Find unit sample response of the filter that generates $y(n)$ from $w(n)$.
 - ii) Find autocorrelation of $y(n)$.
- b) Implement third order FIR filter $H(z) = 1 + 0.5z^{-1} - 0.1z^{-2} - 0.5z^{-3}$ using Lattice structure and stepdown recursion having the vector coefficient, $a_3 = [1, 0.5, -0.1, -0.5]^T$. [3]
- c) Compare parametric and Nonparametric methods for power spectrum estimation. [3]

Q6) a) What are the advantage of lattice filters? [3]

b) A third order all pole Pade's approximation to a signal $x(n)$ has been found to be $H(Z) = \frac{1}{1 + 2z^{-1} + z^{-2} + 3z^{-3}}$

What information about $x(n)$ can be obtained from this model? [4]

c) Enlist advantages of NLMS over LMS. [3]

Q7) a) Explain and derive the algorithm for Bartlett Method. [4]

b) Explain steepest descent algorithm in brief. [3]

c) Define : [3]

- i) Probability distribution function.
- ii) Probability density function.

- Q8)** a) What is Recursive Least Squares? State condition of growing window RLS algorithm. [3]
- b) Write a short note on spectral factorization. [3]
- c) Bartlett's method is used to estimate the power spectrum of a process for a sequence of $N = 2000$ Samples. [4]
- i) What is the minimum length L that may be used for each sequence if we are to have a resolution of $\Delta f 0.005$?
- ii) Explain why it would not be advantageous to increase L beyond the value found in (i).



Total No. of Questions : 7]

SEAT No. :

PA-736

[Total No. of Pages : 2

[5928]-203

**M.E. (E & TC) (Signal Processing)
STILL IMAGE & VIDEO COMPRESSION
(2017 Pattern) (Semester - III) (604402)**

Time : 3 Hours]

[Max. Marks : 50

Instructions to the candidates:

- 1) *Answer any 5 questions.*
- 2) *Your answers will be valued as a whole.*
- 3) *Figures to the right indicated full marks.*
- 4) *Assume suitable data, if necessary.*

- Q1)** a) How vector quantization works? Explain with example. What are the advantages of vector quantization over scalar quantization. [5]
b) Explain the concept of Fractals. Explain how fractals are used for compression. [5]
- Q2)** a) Explain with the neat schematic two band sub-band encoder & decoder in detail. [5]
b) Explain Embedded zerotree coder with example. [5]
- Q3)** a) What is temporal redundancy? How motion estimation algorithm is useful in reducing temporal redundancy. [5]
b) Explain the concept of group of pictures concept in MPEG - I in detail. Explain all I, P, B and D type pictures. [5]
- Q4)** a) Explain MPEG-I video compression standard in detail. [5]
b) Explain MPEG Audio coding in detail. [5]
- Q5)** a) Explain the concept of Block based motion Estimation in detail. [5]
b) What is the difference between MPEG-I and MPEG-II standard. Explain the scalability feature of MPEG-II standard. [5]

P.T.O.

- Q6)** a) Explain fast motion estimation in H. 264 and prediction selection. [5]
b) Explain the Linde-Buzo-Gray Algorithm in detail. [5]

Q7) Explain JPEG 2000 standard with respect to [10]

- a) Preprocessor
- b) Core encoder
- c) Post processing
- d) ROI encoding
- e) Scalability



Total No. of Questions : 08]

SEAT No. :

PA-737

[Total No. of Pages : 2

[5928]-204

M.E. (E & TC) (VLSI & Embedded Systems)

DIGITAL CMOS DESIGN

(2017 Pattern) (Semester - I) (504201)

Time : 3 Hours]

[Max. Marks : 50

Instructions to the candidates:

- 1) *Answer any five questions.*
- 2) *Assume suitable data, if necessary.*
- 3) *Neat diagrams must be drawn wherever necessary.*
- 4) *Use of electronic pocket calculator is allowed.*
- 5) *Figures to the right indicate full marks.*

Q1) a) Draw the ac equivalent ckt of MOSFET and explain the parasitic capacitances in detail. [5]

b) Explore linear, saturation and cut off regions of MOSFET characteristics. Explain qualitatively. [5]

Q2) a) Derive the expression for static power dissipation in MOSFET. [5]

b) Give the expression for propagation delay in CMOS ckt. Explain each term in detail. [5]

Q3) a) What is meant by technology scaling? Explain any one type in detail. [4]

b) With the help of suitable diagrams, explain CMOS fabrication process in brief. [4]

c) Draw the stick diagram of CMOS Inverter. [2]

P.T.O.

- Q4)** a) With the help of suitable example and diagrams, explain logical efforts in detail. [4]
b) Write note on delay in multistage logic networks. [4]
c) What is Fan-in? What is its significance in ckt design? [2]
- Q5)** a) Starting from CMOS Inverter, explore the Pull-Up network and Pull-Down network based schematic of NAND gate. [4]
b) Compare CMOS NAND & NOR ckts w.r.t. area, power & delay. [4]
c) Write note on pass transistor logic technique. [2]
- Q6)** a) What is need of transmission gate? Draw and comment on logic 0/1, resistances and delay. [4]
b) Draw 8:1 Mux using transmission gates. Compare with conventional method. [4]
c) What are the sources of meta-stability? [2]
- Q7)** a) What is dynamic circuit? List typical properties. [4]
b) Why are differential circuits required? Explain with ckt and waveforms. [4]
c) Write note on static CMOS. [2]
- Q8)** a) Draw BiCMOS ckt. List merits and demerits. [4]
b) Compare various ckt families w.r.t. power, delay & area. [4]
c) Write note on low power design techniques. [2]



Total No. of Questions : 08]

SEAT No. :

PA-738

[Total No. of Pages : 2

[5928]-205

M.E. (Electronics & Telecommunication)

(VISI & Embedded system)

RECONFIGURABLE COMPUTING

(2017 Pattern) (Semester - I) (504202)

Time : 3 Hours]

[Max. Marks : 50

Instructions to the candidates:

- 1) *Answer any five questions out of eight questions*
- 2) *Neat diagram must be drawn wherever necessary.*
- 3) *Figures to the right side indicate full marks.*
- 4) *Use of Calculator is allowed,*
- 5) *Assume suitable data if necessary.*

Q1) a) State and explain reconfigurable device characteristics. [5]

b) How would you modify the present multicontext FPGA to convert into RFPGA? [5]

Q2) a) State & explain about Reconfigurable computing. [5]

b) State major advantages of Reconfigurable computing with example. [5]

Q3) a) What is a LUT? How many Boolean functions can a K-input LUT implement? [5]

b) Explain in detail the role of LUTs in FPGAs. [5]

Q4) a) Explain Software defined Radio. [5]

b) How would you modify the present multicontext FPGA to convert into RFPGA? [5]

P.T.O.

- Q5)** a) What is DPGA? Draw and explain architecture of DPGA. [5]
b) What are the research challenges in the design and development of Reconfigurable devices? [5]
- Q6)** a) Explain hierarchical interconnects in detail. What are its effects on the performance of the reconfigurable device? [5]
b) What is Rent Rule? Explain its importance. [5]
- Q7)** a) What is partially reconfigurable computing? Is it supported in any present device? [5]
b) How do you decide that the task needs fully reconfigurable device? [5]
- Q8)** a) What are working RC examples? What tasks are being performed by them? [5]
b) What is the difference between coarse-grain and fine-grain reconfigurable devices? [5]



Total No. of Questions : 08]

SEAT No. :

PA-739

[Total No. of Pages : 2

[5928]-206

M.E. (E & TC) (VLSI & Embedded Systems)

EMBEDDED SYSTEM DESIGN

(2017 Pattern) (Semester - I) (504203)

Time : 3 Hours]

[Max. Marks : 50

Instructions to the candidates:

- 1) *Answer any five questions out of eight questions.*
- 2) *Figures to the right indicate full marks.*
- 3) *All questions carry equal marks.*
- 4) *Assume suitable data if necessary.*

- Q1)** a) State and explain any five design metrics used for the design of an Embedded System. [6]
- b) List the different types of life cycle models in embedded system. Explain waterfall model of embedded system with suitable block diagram. [4]
- Q2)** a) Draw and explain Embedded system architecture. What are the different Categories of an Embedded System? [6]
- b) What is Raspberry Pi? Discuss the features of Raspberry Pi. [4]
- Q3)** a) Explain the features of ARM CORTEX series and improvement of ARM CORTEX series over classical series. [6]
- b) Explain the CAN protocol with suitable diagram with reference to ARM CORTEX M3 microcontroller. [4]
- Q4)** a) Features of General Purpose Input Output (GPIO) in LPC 1768. Explain the function of Pin connect block and PINSEL register in LPC 1768. [6]
- b) Draw and explain the structure of CMSIS Standard of Cortex series. [4]

P.T.O.

- Q5)** a) What is a bootloader? Explain important tasks performed by a bootloader in an Embedded Linux, Compare BIOS and bootloader. [6]
b) Explain how kernel initialization and space initialization is carried out in Embedded Linux. [4]
- Q6)** a) Draw Embedded Linux System architecture. Describe the functions of each block in detail. [6]
b) Explain Flash File System in an Embedded Linux System. [4]
- Q7)** a) Discuss an Automated Meter Reading (AMR) as embedded system case study with [6]
i) Block diagram
ii) Design considerations
iii) Algorithm/flowchart
b) What is EMI/ RFI analysis? Discuss steps involved in certification and documentation of EMI/RFI. [4]
- Q8)** a) Design an embedded system for Digital Camera and explain its design and algorithm in detail. [6]
b) Explain testing and documentation for embedded system: [4]



Total No. of Questions : 8]

SEAT No. :

PA-740

[Total No. of Pages : 2

[5928]-207

M.E. (E & TC) (VLSI & Embedded Systems)

ANALOG CMOS DESIGN

(2017 Pattern) (504207) (Semester - II)

Time : 3 Hours]

[Max. Marks : 50

Instructions to the candidates :

- 1) *Attempt any five questions.*
- 2) *Figures to right indicates full marks.*
- 3) *Assume suitable data if necessary.*

Q1) a) What are the performance parameters of the voltage reference circuit? Explain its in brief. [5]

b) With suitable schematic explain the concept of weak 0 and weak 1. [5]

Q2) a) How does MOSFET behaves as PN diode? What are its applications? Give the expressions for its DC current and dynamic resistance. [5]

b) With the help of a diagram, explain small signal high frequency model for MOS transistor. Also draw large signal model. [5]

Q3) a) What do you mean by large signal, small signal analysis? Draw schematic of CMOS difference amplifier with current mirror load, give the expression for G_{md} , $ICMR$, $CMRR$, and 3 dB frequency. [5]

b) What are dominant noises in CMOS op-amp? List the techniques to reduce this noise. Explain one of the technique in detail. [5]

Q4) a) Compare various types of inverting CMOS op-amp amplifier on the basis of voltage gain and output resistance. [5]

b) What is need of cascode amplifier? Draw its schematic also explain the advantages & disadvantages over the cascode amplifier. [5]

P.T.O.

- Q5)** a) Draw the schematic of comparator. State its static and dynamic characteristics. Also explain the applications of comparator. [5]
- b) Find the propagation delay in comparator that has a slew rate of $1\text{V}/\mu\text{s}$ and an output swing of 10V . [2]
- c) What is frequency compensation? List different frequency compensation techniques. [3]
- Q6)** a) Write a note on the stability of op-amp & its effects on slew rate. [5]
- b) Draw and explain the following analog circuits (any two): [5]
- i) Cascode current source.
 - ii) CMOS comparator
 - iii) Common source amplifier with current mirror source load
- Q7)** a) What are the types of mixer? Explain any one with the help of mathematical analysis in detail. [4]
- b) With the help of a schematic, explore the design steps of a single-ended LNA. [4]
- c) Explain spurs in a mixer. [2]
- Q8)** a) Draw the schematic of a single-ended low noise amplifier (LNA). What are the drawbacks & how will they be overcome in a differential LNA? [5]
- b) What are the differences between passive & active mixers? Draw & explain their architectures. [5]



Total No. of Questions : 8]

SEAT No. :

PA-741

[Total No. of Pages : 2

[5928]-208

M.E. (E & TC) (VLSI and Embedded System)

SYSTEM ON CHIP

(2017 Pattern) (Semester - II) (504208)

Time : 3 Hours]

[Max. Marks : 50

Instructions to the candidates:

- 1) *Answer any five questions.*
- 2) *Neat diagrams must be drawn wherever necessary.*
- 3) *Figures to the right side indicate full marks.*
- 4) *Use of calculator is allowed.*
- 5) *Assume suitable data if necessary.*

Q1) a) What do you mean by Control Flow Modeling and enlist the Limitations of Data Flow Models? **[4]**

b) Write a short note on driving factor of hardware and software co-design? **[6]**

Q2) a) Write a short note on data flow model and its advantages? **[4]**

b) Write a detailed note on RTL synthesis? **[6]**

Q3) a) Write a short note on RISC pipeline? **[4]**

b) Explain different Timing Parameters for Digital Logic? **[6]**

Q4) a) Explain the difference between the following terms : **[6]**

- i) Control hazard and data hazard
- ii) Delayed branch and conditional branch

b) Explain time multiplexing of two hardware-Module ports over a single control shell. **[4]**

P.T.O.

- Q5)** a) What are Causes of Power Dissipation? [4]
b) Write a note on Bus Synchronization along with the challenges in it and enable Synchronization Method? [6]
- Q6)** a) Which are the Factors Affecting Delay and Slew? [4]
b) What is the need of memory optimization and management in SoC? [6]
- Q7)** a) What is Hybrid Power Management Technique? [4]
b) Write a note on 'A SOC Controller for Digital Still Camera'. [6]
- Q8)** a) Explain energy management techniques for SoC design. [4]
b) What are the Design Issues and Techniques for image codec? [6]



Total No. of Questions : 8]

SEAT No. :

PA-742

[Total No. of Pages : 2

[5928]-209

M.E. (E & TC) (VLSI & Embedded Systems)

EMBEDDED AUTOMOTIVE SYSTEMS

(2017 Pattern) (504209) (Semester - II) (Credit System)

Time : 3 Hours]

[Max. Marks : 50

Instructions to the candidates :

- 1) *Solve any five questions.*
- 2) *Assume suitable data if necessary.*
- 3) *Neat diagrams must be drawn wherever necessary.*

Q1) a) What is hybrid technology? Explain various operating models and compare advantages and disadvantages of each. [5]

b) Compare active safety & passive safety with suitable example. [5]

Q2) a) What is hybrid technology? Explain various operating models and compare advantages and disadvantages of each. [5]

b) Explain the open loop and closed loop control mode. [5]

Q3) a) Explain with the aid of a labeled sketch the operation of a wheel speed sensor. [5]

b) What are selection criteria of sensors for automotive applications. [5]

Q4) a) Explain the closed loop ignition control with its waveform. [5]

b) Make a clearly labeled sketch to show an exhaust gas recirculation system. [5]

Q5) a) Draw & explain electronic fuel control and electronic ignition system configuration. [5]

b) Explain the components of active steering system. [5]

P.T.O.

- Q6)** a) Comment on Anti-lock braking system & Electronic steering system. **[5]**
b) Explain the effect of Exhaust gas recirculation and effect of spark timing on performance of engine. **[5]**
- Q7)** a) Compare LIN & CAN with respect to automotive applications. **[5]**
b) Explain Protocol wakeup & startup with respect to Flex-Ray protocol. **[5]**
- Q8)** a) With respect to CAN explain error handling and protocol extension. **[5]**
b) Enlist the control modes in automotive and explain anyone in detail. **[5]**



Total No. of Questions : 8]

SEAT No. :

PA-597

[Total No. of Pages : 2

[5928]-21

M.E. (Civil) (Geotechnical Engineering)

ROCK MECHANICS

(2017 Credit Course) (501123) (Semester - I)

Time : 3 Hours]

[Max. Marks : 50

Instructions to the candidates:

- 1) *Attempt any 5 questions from the 8 questions.*
- 2) *Neat diagrams must be drawn wherever necessary.*
- 3) *Figures to the right indicate full marks.*
- 4) *Use of logarithmic tables, slide rule, Mollier charts, electronics pocket calculator and steam tables is allowed.*
- 5) *Assume suitable data if necessary.*

- Q1)** a) What are the different index properties of rock mechanics? Explain any one in detail [6]
b) Explain the importance of rock mechanics for dry underground excavations. [4]
- Q2)** a) Write a note Rock Grouting. [4]
b) Explain Rock Blasting. [6]
- Q3)** a) State and explain the stresses around circular opening with sketch. [6]
b) Explain Flat Jack Method. [4]
- Q4)** a) List out and explain the different modes of rock failure. [6]
b) Explain the Mohr Coulomb failure criteria for rocks. [4]
- Q5)** a) What are the factors affecting the rupture behavior of rock. [5]
b) Describe failure propagation of jointed rocks. [5]

P.T.O.

- Q6)** a) Write a note on analysis of general slip surface. [5]
b) Explain principle of limit equilibrium method for the analysis of rock structure. [5]
- Q7)** a) Discuss stress and deflection in rock under footing. [5]
b) Write a note on allowable bearing pressure for rock foundations. [5]
- Q8)** a) Write a note on plastic behavior around tunnels. [5]
b) Write a note on review of design methods of tunnels. [5]



Total No. of Questions : 8]

SEAT No. :

PA-743

[Total No. of Pages : 2

[5928]-210

**M.E. (E & TC) (VLSI & Embedded System)
TESTING AND VERIFICATION OF VLSI CIRCUITS
(2017 Pattern) (Semester - III) (604201)**

Time : 3 Hours]

[Max. Marks : 50

Instructions to the candidates:

- 1) Answer any 5 questions from the following.*
- 2) Neat diagrams must be drawn wherever necessary.*
- 3) Figures to the right indicate full marks.*
- 4) Assume suitable data, if necessary.*

Q1) a) Briefly discuss how VLSI technology trends have affected the domain of testing. **[5]**

b) Differentiate between Defect, Fault and Error. **[5]**

Q2) a) List different types of testing VLSI. Explain any two in brief. **[6]**

b) Differentiate between verification and testing with respect to VLSI process. **[4]**

Q3) a) What is the need of fault simulation. Explain in details serial fault simulation algorithm. **[5]**

b) Explain fault equivalence of combinational circuits with suitable examples. **[5]**

Q4) a) Explain briefly observability and controllability. **[5]**

b) Differentiate between combinational circuit test generation and sequential circuit test generation. **[5]**

P.T.O.

- Q5)** a) With the help of neat diagram explain LFSR and signature compaction of BIST. [5]
b) How Analog testing is different than digital testing. [5]
- Q6)** a) Explain need of DFT. Also explain scan architecture briefly. [5]
b) Explain different test pattern generation methods for BIST. [5]
- Q7)** a) Write a short note on “SOC Testing”. [5]
b) Write short note on ATPG. [5]
- Q8)** a) Write a short note on “Embedded core testing”. [5]
b) State importance of avoiding design errors in hardware design. [5]



Total No. of Questions : 8]

SEAT No. :

PA-744

[Total No. of Pages : 2

[5928]-211

M.E. (E & TC) (VLSI and Embedded Systems)

ASIC DESIGN

(2017 Pattern) (Semester - III) (604202)

Time : 3 Hours]

[Max. Marks : 50

Instructions to the candidates:

- 1) *Attempt any 5 questions out of 8.*
- 2) *Neat diagrams must be drawn whenever necessary.*
- 3) *Figures to the right indicate full marks.*
- 4) *Assume suitable data, if necessary.*

- Q1)** a) With neat flow chart explain in detail ASIC Design Flow. [5]
b) With neat labeled diagram describe different types of ASIC. [5]
- Q2)** a) Explain VHDL code and test-bench code for D-flip-flop. [5]
b) Write short note on logic synthesis and simulation. [5]
- Q3)** a) Differentiate floorplanning and placement in ASIC design. [4]
b) How to reuse any ASIC design? Give one example. [4]
c) List different CAD tools used in ASIC Design. [2]
- Q4)** a) With neat labeled diagram explain clock distribution technique in ASIC. [4]
b) Differentiate global routing and detailed routing. [4]
c) Give example of Left-edge algorithm and comment on it. [2]
- Q5)** a) How false path detection is carried out in application specific integrated circuits. [4]
b) Write short note on static timing analysis. [4]
c) How to estimate logic delays in sequential logic design. [2]

P.T.O.

- Q6)** a) Write short note on mixed mode design in ASIC. [4]
b) Describe in brief signal integrity issues in ASIC Design. [4]
c) What are the time related constraints? Explain with one example. [2]
- Q7)** a) Draw and explain linear feedback shift register in detail. [4]
b) Write short note on Joint Test Action Group. [4]
c) Explain basic automatic test pattern generator (ATPG) algorithm for $A'B+BC$. [2]
- Q8)** a) Explain in detail physical faults occurred in ASIC. [4]
b) Write short note on memory testing. [4]
c) Differentiate Scan test Vs Partial test. [2]



Total No. of Questions : 8]

SEAT No. :

PA-598

[Total No. of Pages : 2

[5928]-22

**M.E. (Civil) (Geotechnical Engineering)
GEO-ENVIRONMENTAL ENGINEERING
(2017 Credit Pattern) (Semester - I) (501125)**

Time : 3 Hours]

[Max. Marks : 50

Instructions to the candidates:

- 1) *Attempt Q.1 or Q.2, Q.3 or Q.4, Q.5 or Q.6, Q.7 or Q.8.*
- 2) *Neat diagrams must be drawn wherever necessary.*
- 3) *Figures to the right indicates full marks.*
- 4) *Assume suitable data, if necessary and clearly state.*
- 5) *Use of cell phone is prohibited in the examination hall.*
- 6) *Use of electronic pocket calculator is allowed.*

- Q1)** a) State the different characteristics of solid waste? Explain any one. [4]
b) Discuss on field evolution of permeability. [5]

OR

- Q2)** a) Explain the process of solid waste determination. [4]
b) Discuss in brief sources and effect of sub-surface contamination. [5]

- Q3)** a) What aspects are being considered for planning and design in waste disposal in land fill? [5]
b) State the various disposal methods and explain any one. [4]

OR

- Q4)** a) State types of barrier materials used in land fill and explain any one. [4]
b) Describe Ash pond and Trailing ponds in brief. [5]

- Q5)** a) State any four advantages and disadvantages of landfill method. [8]
b) Discuss properties and Geotechnical reuse of waste. [8]

OR

P.T.O.

- Q6)** a) Explain the different engineering properties of solid waste. [8]
b) Discuss the process of reclamation of old waste dump. [8]

- Q7)** a) Discuss in detail single and double lined landfill. [8]
b) Describe “land fill construction”. [8]

OR

- Q8)** a) Describe application of Geo-synthetics in waste disposal design. [8]
b) State the different types and application of clay liners. [8]



Total No. of Questions : 8]

SEAT No. :

PA-599

[Total No. of Pages : 2

[5928]-23

M.E. (Civil - Geotechnical Engineering)
ADVANCED FOUNDATION ENGINEERING
(2017 Pattern) (Semester - II) (501127) (Credit)

Time : 3 Hours]

[Max. Marks : 50

Instructions to the candidates:

- 1) *Answer Q.1 or Q.2, Q.3 or Q.4, Q.5 or Q.6, Q.7 or Q.8.*
- 2) *Figures to the right indicate full marks.*
- 3) *Assume Suitable data, if necessary.*
- 4) *Use of electronic pocket calculator is allowed in the examination.*
- 5) *Neat diagrams must be drawn wherever necessary.*

Q1) a) Explain in detail standard penetration test. **[4]**

- b) Calculate the ultimate bearing capacity per unit area of a strip footing 1m wide and 1m deep when unit weight of soil 18 kN/m³, cohesion is 20 kN/m², $\phi = 20^\circ$, $N_c = 17.5$, $N_q = 7.5$, $N_\gamma = 5$. **[5]**

OR

Q2) a) Write how to design footing with eccentric loading. **[4]**

- b) Write down criteria for spacing of bores and depth of exploration. **[5]**

Q3) a) Write in detail what is modulus of subgrade reaction and how to determine it. **[4]**

- b) Find the depth of embedment for the sheet pile which support 6m cohesion less backfill with unit weight 17 kN/m³ and $\phi = 30^\circ$. **[5]**

OR

Q4) a) Write a note on type and design of anchors. **[4]**

- b) Determine the net ultimate bearing capacity of a mat foundation measuring 15m \times 10 m on a saturated clay with $C_u = 95$ kN/m². $\phi = 0$, $D_f = 2$ m. **[5]**

P.T.O.

- Q5) a)** Explain in detail uplift resistance of pile & vertical piles subjected to lateral loads. [8]
- b) A group of 9 piles arranged in square pattern with diameter and length of each pile as 25 cm and 10 m respectively, is used as a foundation in soft clay deposit. Tacking UCS of clay as 12 kN/m^2 and pile spacing as 100cm c/c. Find load capacity of group. Assume bearing capacity factor $N_c = 9$ Adhesion factor = 0.75, FOS= 2.5. [8]

OR

- Q6) a)** Write down Hrennikoofs method and Brills approach regarding pile foundation. [8]
- b) A group of 16 piles of 600 mm diameter is arranged in a square pattern with c/c spacing of 1.2m. The piles are 10m long and embedded in soft clay with cohesion of 30 kN/m^2 . Bearing resistance may be neglected for the piles. Adhesion factor is 0.6. Determine the ultimate load carrying capacity of pile group. [8]

- Q7) a)** Write a note on tilt and shift of well foundation. [8]
- b) Discuss lateral stability of well foundation. [8]

OR

- Q8) a)** Write a note on bearing capacity and depth of well foundation. [8]
- b) Explain in detail stability analysis of cellular cofferdam. [8]



Total No. of Questions: 10]

SEAT No. :

PA-745

[5928]-232

[Total No. of Pages :2

M.E. Production (Robotics and Automation)
ROBOTICS BASED INDUSTRIAL AUTOMATION
(2017 Pattern) (Semester-I) (511503)

Time : 3 Hours]

[Max. Marks : 50

Instructions to the candidates:

- 1) *Answer Q1 or Q2, Q3 or Q4, Q5 or Q6, Q7, or Q8, Q9 or Q10.*
- 2) *Neat diagrams must be drawn wherever necessary.*
- 3) *Figures to the right indicate full marks.*
- 4) *Assume suitable data, if necessary.*
- 5) *Use of cell phone is prohibited in the examination hall*
- 6) *Use of electronic pocket calculator is allowed.*

- Q1) a) Elaborate automation principles and strategies. [5]**
b) What are the system design considerations for automated transfer machines? [5]

OR

- Q2) a) A rotary worktable is driven by a Geneva mechanism with six slots. The driver rotates at 30rev/min. determine the cycle time, available process time, and the lost time each cycle indexing the table. [5]**
b) Give analysis of transfer lines with no internal storage. [5]

- Q3) a) Explain general considerations on trajectory planning. [5]**
b) Determine the time required to complete the move and velocity of each joint for the three-axis RRR manipulator to travel the following distances under jointed interpolation motion: joint 1= 30°, joint2 = 60°, joint3 = 90°. The maximum velocity of any joint is 30°/S, however no joint may travel at greater than 90 percentage of maximum velocity. Neglect of acceleration and deceleration. [5]

OR

- Q4) a) Give requirements for a manipulator to follow a line. [5]**
b) Differentiate between joint space motion and cartesian motion. [5]

- Q5) a) Why Ubuntu is preferred for installation of ROS? [5]**
b) Give importance of C-make file in installation of ROS. [5]

OR

P.T.O.

- Q6)** a) Write the use of Gazebo simulation. [5]
b) What are the essential components of a ROS? [5]

- Q7)** a) What are the different robot programming are available? Explain one in brief. [5]
b) Explain important parameters of robot vision. [5]

OR

- Q8)** a) Explain SCORBOT. [5]
b) What is parameter server? Give its importance. [5]

- Q9)** a) Describe about basic elements in Ladder logic programming [5]
b) What are counters? Give types of counters [5]

OR

- Q10)**a) How to test and commission a PLC system? [5]
b) Draw a ladder diagram for a system where five liquids are to be mixed in same proportion. After mixing the mixture is to be packed in tins of one-liter capacity. [5]



Total No. of Questions: 5]

SEAT No. :

PA-746

[5928]-239

[Total No. of Pages : 3

M.E. (Information Technology)
MATHEMATICAL FOUNDATION OF INFORMATION
TECHNOLOGY
(2017 Pattern) (Semester-I) (514401)

Time : 3 Hours]

[Max. Marks : 50

Instructions to the candidates:

- 1) *All questions are compulsory.*
- 2) *Neat diagrams must be drawn wherever necessary.*
- 3) *Figures to the right indicate full marks.*
- 4) *Assume suitable data, if necessary.*

Q1) Solve any two.

- a) Assume the following relationship for revenue and cost functions. Find out at what level of output x , where x is measured in tons per week, profit is maximum.

$$R(x) = 1000x - 2x^2 \text{ and } C(x) = x^3 - 59x^2 + 1315x + 5000. \quad [5]$$

- b) Find the probability that in tossing a fair coin four times there will appear [5]

- i) 3 heads,
- ii) 2 tails and 1 head,
- iii) at least 1 head,
- iv) not more than 1 tail

- c) Suppose a genetic algorithm uses chromosomes of the form $x = abcdefgh$ with a fixed length of eight genes. Each gene can be any digit between 0 and 9. Let the fitness of individual x be calculated as: [5]

$$f(x) = (a+b) - (c+d) + (e+f) - (g+h),$$

and let the initial population consist of four individuals with the following chromosomes:

$$x_1 = 65413532$$

$$x_2 = 87126601$$

$$x_3 = 23921285$$

$$x_4 = 41852094$$

Evaluate the fitness of each individual, showing all your workings, and arrange them in order with the fittest first and the least fit last.

P.T.O.

Q2) Solve any two.

- a) Suppose on an average 1 house in 1000 in a certain district has a fire during a year. If there are 2000 houses in that district, what is the probability that exactly 5 houses will have a fire during a year? [5]
- b) The Cannon Hill furniture Company produces tables and chairs. Each table takes four hours of labor from the carpentry department and two hours of labor from the finishing department. Each chair requires three hours of carpentry and one hour of finishing. During the current week, 240 hours of carpentry time are available and 100 hours of finishing time. Each table produced gives a profit of Rs. 70 and each chair a profit of Rs. 50. Define the objective function, Carpentry constraint, Finishing constraint and non negativity conditions. [5]
- c) Obtain the value of median from the following data of the monthly income of 12 employees of a company in Rs. 4391, 5384, 5591, 5407, 6672, 6522, 6777, 6753, 7850, 7490, 9926, 6734. [5]

Q3) Solve any two.

- a) Researchers have conducted a survey of 1600 coffee drinkers asking how much coffee they drink in order to confirm previous studies. Previous studies have indicated that 72% of Americans drink coffee. The results of previous Studies (left) and the survey (right) are below. At $\alpha = 0.05$, is there enough evidence to conclude that the distributions are the same? [5]
- b) Calculate the value of mode for the following data [5]
- | | | | | | | | |
|------------|----|----|----|----|----|----|----|
| Marks : | 10 | 15 | 20 | 25 | 30 | 35 | 40 |
| Frequency: | 8 | 12 | 36 | 35 | 28 | 18 | 9 |
- c) The following mistakes per page were observed in a book, [5]
- | | | | | | |
|---------------------------------------|-----|----|----|---|---|
| Number of mistakes per page | 0 | 1 | 2 | 3 | 4 |
| Number of times the mistakes occurred | 211 | 90 | 19 | 5 | 0 |
- Fit a Poisson distribution to fit data.

Q4) Solve any two.

- a) Solve the knapsack problem using genetic algorithm. [5]
b) Weight of 10 students is as follows. [5]

Sr. No.	1	2	3	4	5	6	7	8	9	10
Weight (kg)	70	44	42	56	42	41	52	46	50	46

Can we say that the variance of the distribution of weight of all students from which the above sample of 10 students was drawn is equal to 20 kgs? Test this at 5% and 1% level of significance.

- c) Explain simplex algorithm with example. [5]

Q5) Solve any two.

- a) Using genetic algorithm maximize $f(x) = x^2$ over $(0,1,2,\dots,31)$ with initial x values of $(13,24,8,16)$. Show one crossover and mutation operation. [5]
b) Using your own institution and your own definition of universe of discourse, write & plot fuzzy membership functions for the designing of washing Machine by considering parameters: {Dirt, Grease, Wash Time}. Assume Dirt & grease on a scale of 0 – 100, Wash Time on a scale of 0–60. [5]
c) Describe the concepts involved in real-coded genetic algorithm. [5]



Total No. of Questions : 08]

SEAT No. :

PA-600

[Total No. of Pages : 2

[5928]-24

M.E. (Civil) (Geotechnical Engineering)
CONSTRUCTION METHODS IN GEOTECHNICAL
ENGINEERING
(2017 Pattern) (Semester - II) (501128)

Time : 3 Hours]

[Max. Marks : 50

Instructions to the candidates:

- 1) *Attempt Q. 1 or Q. 2, Q. 3 or Q. 4, Q.5 or Q. 6 and Q. 7 or Q. 8.*
- 2) *Neat diagram must be drawn wherever necessary.*
- 3) *Figures to the right indicate full marks.*
- 4) *Assume suitable data, if necessary.*
- 5) *Use of electronic pocket calculator is allowed.*

Q1) a) Write short note on micro piling. **[4]**

b) Explain in detail circular cofferdam. **[5]**

OR

Q2) a) Discuss the design criteria for under reamed piles. **[4]**

b) Describe the procedure of setting and driving of sheet piles. **[5]**

Q3) a) Explain in detail launching and towing of caissons. **[4]**

b) Describe the procedure of construction of pneumatic caisson with sketch. **[5]**

OR

Q4) a) Explain the procedure of seal construction of grout intrusion method. **[5]**

b) Discuss how cofferdam will destroyed by surge. **[4]**

Q5) a) Which equipments are used for drilling in rock excavation? Explain. **[8]**

b) Write down the selection criteria of explosives for rock excavations. **[8]**

OR

P.T.O.

- Q6)** a) Explain in detail evaluation and planning required for rock excavation. [8]
b) Write notes on over brake control and pre-splitting. [8]

- Q7)** a) Explain full face tunnelling without support method. [8]
b) Differentiate between the classical and mining methods. [8]

OR

- Q8)** a) Discuss multistage classical method of tunnelling. [8]
b) Write notes on shield tunneling and sinking caisson method. [8]



Total No. of Questions: 7]

SEAT No. :

PA-747

[5928]-240

[Total No. of Pages :2

M.E. (Information Technology)
ADVANCE SOFTWARE ENGINEERING & PROJECT
MANAGEMENT
(2017 Pattern) (Semester-I) (514402)

Time : 3 Hours]

[Max. Marks : 50

Instructions to the candidates:

- 1) *Answer any five questions from seven questions.*
- 2) *Neat diagrams must be drawn wherever necessary.*
- 3) *Figures to the right indicate full marks.*
- 4) *Use of Calculator is allowed.*
- 5) *Assume suitable data, if necessary.*

- Q1)** a) Explain Prescriptive Process Models. **[5]**
- b) Define the concept of Software Requirement Engineering. Give requirement elicitation for ATM transaction system. **[5]**
- Q2)** a) Define and explain the following terms with suitable eg. **[5]**
- i) Refinement
- ii) Separation of concerns
- b) Explain Web Design pyramid with suitable diagram. **[5]**
- Q3)** a) Explain the Agile Process Model with suitable eg. or diagram. **[5]**
- b) Describe the XP concepts of refactoring and pair programming in your own words. **[5]**
- Q4)** a) Why Project Planning is required? Explain the popular techniques of Project planning, scheduling and estimation. **[5]**
- b) Discuss various code cloning techniques with eg. **[5]**

P.T.O.

- Q5)** a) What is program inspections? Why are they required? What types of error are unlikely to be discovered through inspections? [5]
b) Explain the various challenges in software project maintenance. [5]
- Q6)** a) Explain the concept of Pair Programming. [5]
b) Explain Service-oriented Software Engineering with respect to case study. [5]
- Q7)** Write a short note on any two [10]
a) User Interface Design
b) GERT
c) Aspect Oriented Programming.



M.E. (Information Technology)
APPLIED ALGORITHMS
(2017 Pattern) (Semester-I) (514403)

Time : 3 Hours]

[Max. Marks : 50

Instructions to the candidates:

- 1) *Answer any five questions.*
- 2) *Neat diagrams must be drawn wherever necessary.*
- 3) *Figures to the right indicate full marks.*
- 4) *Assume suitable data, if necessary.*

- Q1)** a) Prove by contradiction that their exist infinite no. [2]
 b) Find minimum cost spanning tree using Kruskals algorithm for a given graph. [4]

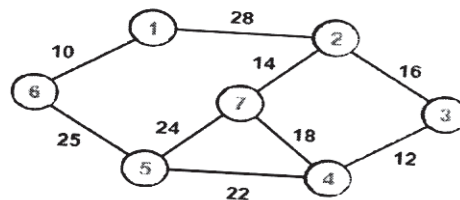

- c) Prove by mathematical induction that sum of cubes of first n positive integers is equal to the square of sum these integers. [4]

- Q2)** a) Explain and analyze Rabin karp algorithm. [2]
 b) Analyze best, worst and average case of Quick sort in details. [4]
 c) Find the transitive closure of the following graph. [4]

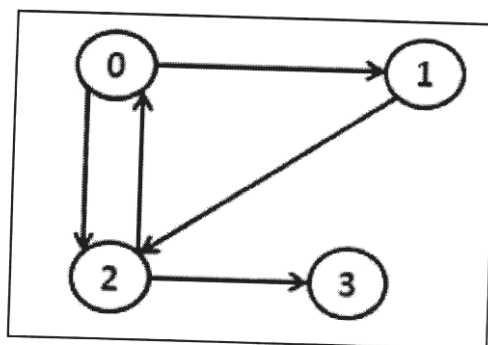

- Q3)** a) Describe the steps for finding out the complexity of non recursive algorithm write the algorithm for insertion sort and find its complexity [3]

- b) Explain the persistent data structure. Explain with figure and write down the algorithm to insert the element in single link list. [3]
- c) Define following terms: [4]
 - i) Polynomial approximation algorithms.
 - ii) Approximation ratio.

- Q4)**
- a) Define the following terms and give example from each class P, NP, NP hard and NP complete. Show their relationship using diagram. [3]
 - b) Explain Chinese remainder theorem. [3]
 - c) State and prove max flow min cut theorem. [4]

- Q5)**
- a) What is randomized algorithm? Explain types of randomized algorithms. [5]
 - b) Write a parallel algorithm for expression evaluation. [5]

- Q6)**
- a) Solve the following salesman problem using approximation algorithm. [5]

0	19	14	16
19	0	17	12
14	17	0	18
16	12	18	0

- b) What is online algorithm? Write and explain obstacle traversal algorithm. Explain with figure zig zag operation on splay tree. [5]
- Q7)**
- a) Show the result of inserting the keys, F, S, Q, K, C, LH, T, V, W, M, R, N, P, A, B, X, Y, D, Z, E in order into an empty B-tree with minimum degree 2. [5]
 - b) Discuss various parallel computational modules and explain how they achieve the parallelism in algorithmic design. [5]
- Q8)**
- a) What are the properties of the red-black tree? Explain delete operation with example. [5]
 - b) Write algorithm for pointer doubling problem. what is its time complexity. [5]



Total No. of Questions: 6]

SEAT No. :

PA-749

[5928]-242

[Total No. of Pages : 1

**M.E. (Information Technology)
RESEARCH METHODOLOGY
(2017 Pattern) (Semester-I) (514404)**

Time : 3 Hours]

[Max. Marks : 50

Instructions to the candidates:

- 1) *Answer any five questions.*
- 2) *Neat diagrams must be drawn wherever necessary.*
- 3) *Figures to the right indicate full marks.*
- 4) *Assume suitable data, if necessary.*

- Q1)** a) Explain the meaning and significance of research. [5]
b) Distinguish between research method and research methodology. [5]
- Q2)** a) Distinguish between alternative hypothesis and null hypotheses. [5]
b) Define the term 'Literature Review'. Enumerate the objectives and significance of literature review. [5]
- Q3)** a) Discuss interview as a technique of data collection. [5]
b) Clearly explain the difference between collection of data through questionnaires and schedules. [5]
- Q4)** a) Mention the different types of report, particularly pointing out the difference between a technical report and a popular report. [5]
b) What do you understand by the Research proposal? Define the criteria for evaluating the Research proposal. [5]
- Q5)** a) What are Intellectual Property rights? Write about its importance. [5]
b) Introduce Indian Patent laws, process of patenting a research finding, Copyright. [5]
- Q6)** a) Discuss practical and efficient three-pass method for reading research papers. [5]
b) Discuss different types of technical papers. [5]



Total No. of Questions : 5]

SEAT No. :

PA-750

[Total No. of Pages : 2

[5928]-243

M.E. (Information Technology)
CYBER SECURITY & FORENSICS
(2017 Pattern) (Semester - II) (514407)

Time : 3 Hours]

[Max. Marks : 50

Instructions to the candidates :

- 1) *All questions are compulsory.*
- 2) *Neat diagrams must be drawn wherever necessary.*
- 3) *Figures to the right indicate full marks.*
- 4) *Assume suitable data, if necessary.*

Q1) Solve any two :

- a) Explain the term Cyber risks and Information security risks. [5]
- b) Check the password scheme on your own computer system. Are there any rules on password length, password format, or password expiry? How are passwords stored in you system? [5]
- c) Explain the term a risk and threat analysis for ATM cash withdrawals, both from the customer's and the bank's viewpoint. [5]

Q2) Solve any two :

- a) What does "tranquillity" mean in the BLP model. [5]
- b) Describe the security rules for the Biba model. [5]
- c) Describe security model - Harrison - Ruzzo - Ullman Model (HRU) in detail. [5]

Q3) Solve any two :

- a) Explain the term key establishment protocols - The Diffie - Hellman Protocol. Needham - Schroeder Protocol. [5]

P.T.O.

- b) Explain cross site scripting with example. [5]
- c) What do you mean by Hypothesis formulation? [5]

Hypothesis - The web server was compromised on or before the time indicated and the attacker was able to move malicious executables to web server. Explain by predictions, evaluation and conclusion.

Q4) Solve any two :

- a) What are the different formats for digital evidence? Explain. [5]
- b) Write a short note on Intrusion Investigation Processes by applying the scientific Method. [5]
- c) Write a short note on cyber stalking. Explain the stages involved in cyber stalking. [5]

Q5) Solve any two :

- a) Explain the term UNIX Forensic Analysis - Boot Process. [5]
- b) Explain how bit locker works against data theft in windows forensics?[5]
- c) Explain with appropriate example how to identify an Alternate data stream on an NTFS system. [5]



Total No. of Questions : 8]

SEAT No. :

PA-751

[Total No. of Pages : 2

[5928]-244

M.E. (Information Technology)
CLOUD AND DATA TECHNOLOGIES
(2017 Pattern) (Semester - II) (514408)

Time : 3 Hours]

[Max. Marks : 50

Instructions to the candidates:

- 1) *Answer any five questions.*
- 2) *Neat diagrams must be drawn wherever necessary.*
- 3) *Figures to the right indicate full marks.*
- 4) *Assume suitable data, if necessary.*

Q1) a) Explain the concept of Cloud Security. **[6]**

b) Explain Data Center Technology of cloud in details. **[4]**

Q2) a) Explain with example Multitenant Technology of Cloud. **[6]**

b) Explain in brief Remote Administration System and Resource Management. **[4]**

Q3) a) Explain concept of Storage Workload Management Architecture of cloud. **[6]**

b) Explain Resource Reservation Architecture of cloud in brief. **[4]**

Q4) a) Write a brief note on : **[6]**

i) MapReduce

ii) Pregel

b) Write a note on Rapid Provisioning Architecture. **[4]**

P.T.O.

- Q5)** a) Explain different Big data Technologies. [6]
b) Write a short note on k-Nearest Neighbors (k-NN) algorithm. [4]
- Q6)** a) Write a brief note on : [6]
i) Kaggle Model
ii) Hubris
b) Explain in details the Data analytic thinking. [4]
- Q7)** a) Explain concept of Data Visualization and fraud detection. [5]
b) Write a brief note on Hadoop technology for data processing. [5]
- Q8)** a) Explain following Algorithms : [6]
i) Naïve Bayes
ii) k-means
b) Explain the dialectical relationship between Cloud computing and Big data. [4]



Total No. of Questions : 6]

SEAT No. :

PA-752

[Total No. of Pages : 4

[5928]-245

M.E. (Information Technology)

INFORMATION TECHNOLOGY ORIENTED OPERATIONS

RESEARCH

(2017 Pattern) (Semester - II) (514409)

Time : 3 Hours]

[Max. Marks : 50

Instructions to the candidates :

- 1) Attempt Q1 or Q2, rest all questions are compulsory.
- 2) Assume Suitable Data, if necessary.
- 3) Neat Diagram must be drawn wherever necessary.
- 4) Figures to the right indicate full marks.

Q1) a) Solve using Simplex Method [6]

Minimize $Z = x_1 + 3x_2$, subject to the constraints

$$x_1 + 2x_2 \geq 18$$

$$2x_1 + 3x_2 \geq 27$$

$$2x_1 + x_2 = 22 \text{ and } x_1, x_2 \geq 0$$

b) Write Short note on “Deriving Solution from the Model”. [4]

OR

Q2) a) Discuss the types of mathematical model [4]

b) Consider the following LP problem [6]

Maximize $Z = 2x_1 + 3x_2$

Subject to : $x_1 + 2x_2 \leq 4$

$$x_1 + x_2 \leq 3 \text{ and } x_1, x_2 \geq 0$$

i) Convert this problem to a minimization problem.

ii) Solve the problem of (i) by the graphical method

P.T.O.

Q3) Attempt any two questions.

- a) Explain the steps in Vogel's Approximation method in Transportation problem. [5]
- b) Consider the following profit and requirement table of a transportation problem, find an optimal solution. [5]

20	5	3	16	14	60
12	15	19	4	10	35
5	13	15	8	18	40
22	45	20	18	30	

- c) Consider the problem of assignment 4 jobs to 4 machines. The assignment costs are given below. Find an optimal way of assignment. [5]

20	16	18	17	-	12
-	16	14	19	18	15
13	15	15	-	21	14
12	-	19	20	12	18
15	17	-	16	13	22

Q4) Attempt any two questions.

- a) Write any four limitations of Game Theory. [5]
- b) i) For what value of λ , the game with following payoff matrix is strictly determinable?

		Player B		
		B1	B2	B3
Player A	A1	λ	6	2
	A2	-1	λ	-7
	A3	-2	4	λ

- ii) Find the ranges of values p and q which will render the entry (2,2) a saddle point for the game.

		Player B		
		B1	B2	B3
Player A	A1	2	4	5
	A2	10	7	q
	A3	4	p	6

[5]

- c) Determine Value of Game. Also indicate that they are fair or strictly determinable. [5]

	B1	B2	B3	B4
A1	6	0	1	9
A2	8	-1	2	3
A3	10	-3	-5	-2
A4	-2	-5	7	4

Q5) Attempt any two questions :

- a) Write short note on dynamic programming and its application. [5]
 b) Use dynamic programming for optimal path from location A to location J (Target Location) of given road network. Cost across locations are mentioned. [5]

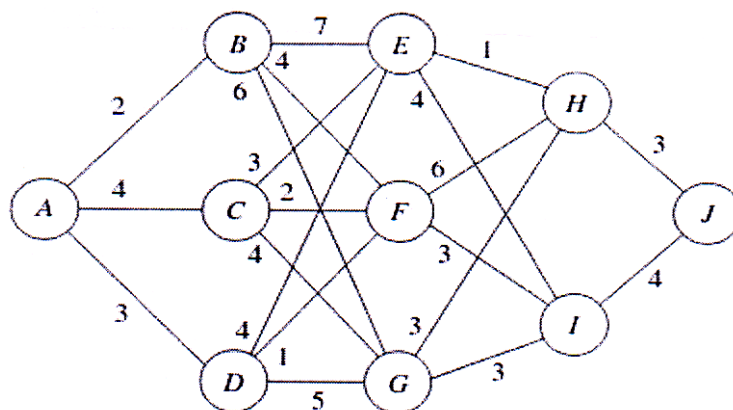

- c) Write short note on characteristics of dynamic programming. [5]

Q6) Attempt any two questions :

- a) Explain algorithm of finding critical path. [5]
- b) Explain the rules devised by Fulkerson for network construction. [5]
- c) The utility data for a network are given below. Determine the total float and identify the critical path. [5]

Activity :	1-2	1-4	1-7	2-3	3-6	4-5	4-8	5-6	6-9	7-8	8-9	9-10
Duration :	3	2	2	5	2	6	8	5	4	4	6	3



Total No. of Questions : 7]

SEAT No. :

PA-753

[Total No. of Pages : 2

[5928]-246

M.E. (Information Technology)
MOBILE AD-HOC NETWORKS
(2017 Pattern) (Semester - III) (5144013)

Time : 3 Hours]

[Max. Marks : 50

Instructions to the candidates:

- 1) *Answer any 5 questions.*
- 2) *Neat diagrams must be drawn wherever necessary.*
- 3) *Figures to the right side indicate full marks.*
- 4) *Use of calculator is allowed.*
- 5) *Assume suitable data if necessary.*

Q1) a) What are the main four categories routing protocols for ad-hoc wireless Network. [5]

b) Draw and explain the architecture of packet radio network. [5]

Q2) a) Differentiate in between IEEE 802.11a and IEEE 802.11b. [5]

b) Explain Ad hoc On-Demand Distance Vector Routing Algorithm in detail. [5]

Q3) a) Explain an Architecture Reference Model for Multicast Routing Protocols. [5]

b) Explain issues in designing a multicast routing protocol. [5]

Q4) a) What are the issues in designing a transport layer protocol for ad hoc wireless networks? [5]

b) Why does TCP not perform well in ad hoc wireless networks? [5]

P.T.O.

- Q5)** a) Explain Network layer attacks. [5]
b) Explain Security-Aware Ad Hoc Routing Protocol in detail. [5]
- Q6)** a) What are the issues and challenges in providing QOS in ad hoc wireless networks. [5]
b) Explain classification of energy management schemes. [5]
- Q7)** Explain the working of multicast core-extraction distributed ad hoc routing (MCEDAR) in detail. [10]



Total No. of Questions : 7]

SEAT No. :

PA-754

[5928]- 247

[Total No. of Pages : 2

**M.E. (Information Technology)
ADVANCED OPERATING SYSTEM
(2017 Pattern) (Semester - III) (5144014)**

Time :3 Hours]

[Max. Marks : 50

Instructions to the candidates:

- 1) *Answer any five questions from seven questions.*
- 2) *Figures to right indicate full marks.*
- 3) *Neat diagram must be drawn wherever necessary.*
- 4) *Assume suitable data, if necessary.*

Q1) a) Differentiate between concept of Processes and Thread in OS [5]

b) Explain the desirable features of a good message passing system. [5]

Q2) a) Describe the mechanism used for synchronization in message passing.[5]

b) Explain the Architecture of Distributed Shared Memory with suitable diagram. [5]

Q3) a) Explain the implementation of RPC mechanism with suitable diagram.[5]

b) Explain any two replacement strategies in DSM. [5]

Q4) a) Explain the concept of Clock synchronization with suitable algorithm.[5]

b) Discuss the features of good Distributed File system. [5]

Q5) a) Explain the election algorithms in a distributed system. [5]

b) Explain the working principle of file caching scheme in DFS. [5]

P.T.O.

Q6) a) Explain the design issues in the file systems wrt any mobile OS of your choice. [5]

b) Explain the architecture of Android OS with suitable diagram. [5]

Q7) Write short notes on following (any two) : [10]

a) Deadlock detection in a distributed systems.

b) Scheduling in Mobile OS

c) Distributed computing models.



Total No. of Questions: 8]

SEAT No. :

PA-755

[5928]-248

[Total No. of Pages : 3

M.E. (Instrumentation and control) (Process instrumentation)

MATHEMATICAL METHOD IN INSTRUMENTATION

(2017 Pattern) (Semester-I) (506101)

Time : 3 Hours]

[Max. Marks : 50

Instructions to the candidates:

- 1) Answer any five questions.
- 2) Figures to the right indicate full marks.
- 3) Use of calculator is allowed.
- 4) Assume suitable data if necessary.

Q1) a) Show that the Vector's $(1,1,1)$, $(1,1,0)$, $(1,0,0)$ is Linearly independent in \mathbb{R}^3 . [4]

b) If $\bar{u} = (-1,1,2)$, $\bar{v} = (2,-1,2)$ then find Euclidean inner product $\langle 2\bar{u} - 3\bar{v}, 3\bar{u} + \bar{v} \rangle$. [4]

c) Define Linear combination of Vector with suitable examples. [2]

Q2) a) Obtain the orthonormal Vector from the following Vectors (Use Gram-schmidt method). $\bar{u}_1 = (1,-3)$, $\bar{u}_2 = (2,2)$ [5]

b) let $\bar{V}_1 = \left(\frac{1}{\sqrt{2}}, 0, \frac{1}{\sqrt{2}} \right)$ and $\bar{V}_2 = \left(\frac{-1}{\sqrt{2}}, 0, \frac{1}{\sqrt{2}} \right)$ be an orthonormal set of Vector's in \mathbb{R}^3 , if $\bar{u} = (1,2,3)$ compute orthogonal projection \bar{u} of W and orthogonal component \bar{u} to W. [5]

Q3) a) Use Runge Rutta method of fourth order to solve $\frac{dy}{dx} = \sqrt{x+y}$, $y(0) = 1$, Find y at $x = 0.2$ taking $h = 0.1$. [5]

b) Obtain Newton Raphson formula to find Inverse and Inverse square root of given numbers. [5]

P.T.O.

- Q4) a)** Find first Four moments about origin and about the mean for a random variable X having density function [5]

$$f(x) = \frac{4x(9 - x^2)}{81}, \quad 0 \leq x \leq 3 \text{ and}$$

$$f(x) = 0, \text{ Otherwise}$$

- b)** Solve by Gauss- seidal iteratoon method [5]

$$27x_1 + 6x_2 - x_3 = 85,$$

$$6x_1 + 15x_2 + 2x_3 = 72,$$

$$x_1 + x_2 + 54x_3 = 110$$

- Q5) a)** A continuous random variable X has a probability density function given by [5]

$$f(x) = 2e^{-x}, x > 0 \text{ and } f(x) = 0, x \leq 0$$

Find

i) $E(x)$

ii) $E(x^2)$.

- b)** Find singular value decomposition of the matrix. $A = \begin{bmatrix} 2 & -1 \\ 2 & 2 \end{bmatrix}$ [5]

- Q6) a)** A Joint PDF of two continuous random variable X and Y is [6]

$$f(x, y) = cxy, \quad 0 < x < 4, \quad 1 < y < 5 \text{ and}$$

$$f(x, y) = 0, \quad \text{Otherwise.}$$

i) Find the value of constant C

ii) Find $P[1 < x < 2, 2 < y < 3]$

iii) Find $P[x \geq 3, y \leq 2]$

- b)** Explain the term's skewness and kurtosis with suitable examples. [4]

- Q7) a)** Assume that the probability of an individual coal miner being killed in a mine accident during a year is $\frac{1}{2400}$. Use approximate statistical distribution to calculate probability that in a mine employing 200 miners, there will be at least one fatal accident in a year. **[5]**
- b) The first four central moments of a distribution are 0, 2.5, 0.7 and 18.75 comment on the skewness and kurtosis of the distribution. **[5]**
- Q8) a)** Explain the term. **[5]**
- i) Moment's.
 - ii) Moment's Generating Function.
- b) Assume that the mean height of soldier to be 68.22 inches with variance 10.8 inches How many soldier in a regiment of 10,000 would you expect to be over 6 feet tall.
(Given : Area at $Z=1.15 = 0.3749$). **[5]**



Total No. of Questions: 7]

SEAT No. :

PA-756

[5928]-249

[Total No. of Pages : 2

M.E. (Process Instrumentation & Control)
TRANSDUCER DESIGN
(2017 Pattern) (Semester-I) (506102)

Time : 3 Hours]

[Max. Marks : 50

Instructions to the candidates:

- 1) *Answer any five questions.*
- 2) *Neat diagrams must be drawn wherever necessary.*
- 3) *Figures to the right indicate full marks.*
- 4) *Use of logarithmic tables, slide rules and electronic pocket calculator is allowed.*
- 5) *Assume suitable data, if necessary.*

- Q1)** a) Write short note on chemical sensor. [5]
b) Suggest the suitable non contact type transducer used to measure the temperature of furnace, elaborate the concept with neat sketch. Describe static and dynamic characteristics of instruments. [5]
- Q2)** a) Explain static and dynamic characteristics of instruments. [5]
b) Write a short notes on MEMS. [5]
- Q3)** a) Explain chemical sensor in detail with neat sketch and state its applications. [5]
b) Differentiate between torque, angular velocity and power. [5]
- Q4)** a) Suggest suitable scheme to measure torque of a rotating shaft using strain gauge. [5]
b) Specify the different level measurement approach's in the industry, suggest suitable transducer used for liquid level measurement. [5]
- Q5)** a) Explain gas sensors in brief and state its applications. [5]
b) Classify and state selection criteria of transducers and illustrate performance characteristics of transducer. [5]

P.T.O.

- Q6)** a) Specify the need of signal conditioning, and explain signal level and bias changes. [5]
b) Explain the role of ADC and DAC in interfacing of sensor with suitable example. [5]
- Q7)** a) Explain the concept of loading divider circuits, and bridge circuits in brief. [5]
b) Comment on pH and conductivity, suggest suitable scheme for pH measurement of water in tank. [5]



Total No. of Questions : 8]

SEAT No. :

PA-601

[Total No. of Pages : 2

[5928]-25

M.E. (Civil - Geotechnical Engineering)
STABILITY OF SLOPES AND EARTH DAM
(2017 Pattern) (501129) (Semester - II)

Time : 3 Hours]

[Max. Marks : 50

Instructions to the candidates:

- 1) *Attempt Q.1 or Q.2, Q.3 or Q.4, Q.5 or Q.6 and Q.7 or Q.8.*
- 2) *Neat diagrams must be drawn wherever necessary.*
- 3) *Figures to the right indicate full marks.*
- 4) *Assume suitable data, if necessary and clearly state.*
- 5) *Use of cell phone is prohibited in the examination hall.*
- 6) *Use of electronic pocket calculator is allowed.*

- Q1)** a) Explain the criteria for long term stability of slopes. [4]
b) State and explain the factors influencing design of earth dam. [5]

OR

- Q2)** a) Discuss the factor of safety considerations for slope stability problems. [5]
b) State the conditions for failure of earth dam and explain them in brief. [4]

- Q3)** a) Sketch the flownet for composite dam section with explanation for the same. [4]
b) Explain the measures for reducing seepage in earthen dam. [5]

OR

- Q4)** a) Derive the 2-D Laplace equation for steady seepage through isotropic soil. [5]
b) State and explain the criteria for stability of foundations of earth dams. [4]

- Q5)** a) What are the objectives of instrumentation in dam? Which are the categories of instruments used in dam? Give examples of each category. [8]
b) Write note on Joint meter and inclinometer with sketches. [8]

OR

P.T.O.

- Q6)** a) What are the parameters for selection of piezometer to be used in earthen dam? Explain any one piezometer with sketch. [8]
- b) Explain how settlement of earth dam is measured with vibrating wire settlement cell and settlement guage. [8]

- Q7)** a) Draw a typical section of road embankment and explain the functions of each component part. [8]
- b) Explain the use of geosynthetics for unstable slopes and as separators.[8]

OR

- Q8)** a) State and explain the design criteria for railway embankment for high speed trains. [8]
- b) Explain various types of landslides with its causes and remedial measures. [8]



Total No. of Questions: 6]

SEAT No. :

PA-757

[5928]-250

[Total No. of Pages : 1

M.E. (Instrumentation & Control) (Process Instrumentation)

INDUSTRIAL AUTOMATION

(2017 Pattern) (Semester-I) (506103)

Time : 3 Hours]

[Max. Marks : 50

Instructions to the candidates:

- 1) *Answer any five questions*
- 2) *Neat diagrams must be drawn wherever necessary.*
- 3) *Figures to the right side indicate full marks.*
- 4) *Use of calculator is allowed.*
- 5) *Assume suitable data, if necessary.*

- Q1)** a) Elaborate HART data integration. [5]
b) Elaborate the data flow and number conversions involved in PLC analog operation. [5]
- Q2)** a) Draw a famous automation hierarchy for an industrial application. Analyze the function of each level of automation hierarchy. [5]
b) Compare MODBUS, Fieldbus and Profibus [5]
- Q3)** a) Develop daisy chain topology to connect three field devices using Field Bus. [5]
b) Discuss tree topology in Foundation Fieldbus with suitable example [5]
- Q4)** a) Comment on Process Hazard Analysis [5]
b) Elaborate the role of Safety Instrumented System (SIS) in Automation [5]
- Q5)** Develop a programmable ladder diagram for: There are two BCD inputs. If A exceeds 355, output F is to go ON; if B exceeds 187, output G is to go ON; if both exceed their listed numbers, output H is to go ON; otherwise, no outputs to be ON. [10]
- Q6)** Design a program for flashing of lamp. It should go off after five flashes. Assume suitable data. [10]



Total No. of Questions: 7]

SEAT No. :

PA-758

[5928]-251

[Total No. of Pages : 1

**M.E. (Process Instrumentation & Control)
RESEARCH METHODOLOGY
(2017 Pattern) (Semester-I) (506104)**

Time : 2 Hours]

[Max. Marks : 50

Instructions to the candidates:

- 1) *Answer any five questions.*
- 2) *Neat diagrams must be drawn wherever necessary.*
- 3) *Figures to the right indicate full marks.*
- 4) *Use of logarithmic tables, slide rule, Mollier charts and electronic pocket calculator and steam table is allowed.*
- 5) *Assume suitable data, if necessary.*

- Q1)** a) Explain scope and objectives of research problem in brief. [5]
b) Distinguish between research method and methodology. [5]
- Q2)** a) Elaborate the techniques involved in formation of research problem. [5]
b) Write a short notes on Linear scaling for receiver and fidelity of instrument. [5]
- Q3)** a) Write a short notes on uncertainty analysis. [5]
b) Differentiate between point estimate and interval estimate. [5]
- Q4)** a) Explain primary and secondary data collection methods. [5]
b) Illustrate asymptotic analysis in brief. [5]
- Q5)** a) Explain hypothesis in details. State the qualities of good hypothesis. [5]
b) Explain the significance of curve fitting in Engineering Research and the procedure to be followed for the same. [5]
- Q6)** a) Discuss the structure of a typical Engineering Research Proposal and in short elaborate each point. [5]
b) Explain: Static & Dynamic Characteristics of instruments. [5]
- Q7)** a) Describe Linear Regression Equation in brief. [5]
b) Explain the layout of research proposal in detail. [5]



Total No. of Questions : 6]

SEAT No. :

PA-759

[Total No. of Pages : 2

[5928]-252

M.E. (Instrumentation & Control) (Process Instrumentation)

PROCESS DYNAMICS AND CONTROL

(2017 Pattern) (Semester - II) (506107)

Time : 3 Hours]

[Max. Marks : 50

Instructions to the candidates:

- 1) *Answer any five questions.*
- 2) *Neat diagram must be drawn wherever necessary.*
- 3) *Figures to the right indicates full marks*
- 4) *Use of Calculator is allowed.*
- 5) *Assume suitable data if necessary.*

Q1) a) Analyze the dynamics of first order process to identify key performance characteristics. [5]

b) Elaborate procedure of IMC for SOPDT process. [5]

Q2) Develop mathematical model of liquid level surge tank from first principle. [10]

Q3) a) Elaborate procedure to obtain an empirical model from the plant data. [5]

b) Frame the Control Objectives for liquid surge tank. [5]

Q4) a) Develop cascade control system to improve the performance of heat exchanger. [5]

b) Comment on Interaction. [5]

Q5) a) Elaborate with neat sketch MRAS. [5]

b) Develop self tuning regulator. [5]

P.T.O.

Q6) The transfer function model of two input two output system is given by,

$$\begin{array}{|l} \frac{12.8e^{-s}}{16.7s+1} \quad \frac{-18.9e^{-3s}}{21s+1} \\ \frac{6.6e^{-7s}}{10.9s+1} \quad \frac{-19.4e^{-3s}}{14.4s+1} \end{array}$$

Determine the RGA matrix, decide pairing of variables and find out static decoupler. **[10]**



Total No. of Questions : 5]

SEAT No. :

PA-760

[Total No. of Pages : 2

[5928]-253

M.E. (Instrumentation and Control) (Process Instrumentation)

EMBEDDED SYSTEM DESIGN

(2017 Pattern) (Semester - II) (506108)

Time : 3 Hours]

[Max. Marks : 50

Instructions to the candidates:

- 1) *All questions are compulsory.*
- 2) *Neat diagrams must be drawn wherever necessary.*
- 3) *Figures to the right indicate full marks.*
- 4) *Assume Suitable data if necessary.*
- 5) *Use of electronic pocket calculator.*

Q1) Attempt any two of the following :

- a) List and elaborate different addressing modes of AVR Microcontroller. [5]
- b) Discuss watchdog timer of AVR microcontroller. [5]
- c) Analyze with suitable block diagram ADC prescaler of AVR μ C. [5]

Q2) Attempt any two of the following :

- a) Elaborate memory organization of ARM processor. [5]
- b) Discuss the registers used in the ARM THUMB instruction set. [5]
- c) Comment on different ARM Development tools. [5]

Q3) Attempt any two of the following :

- a) Compare between SPI vs. I²C. [5]
- b) Elaborate how multiple processors can be connected on RS-485 bus. [5]
- c) Write short note on USB. [5]

P.T.O.

Q4) Attempt any one of the following :

- a) Design embedded system using 8051 μ C for speed control of 1- ϕ Induction Motor. Draw and explain the system with suitable block diagram and circuit diagram. **[10]**
- b) Design & implement Wireless Transceiver for Data Acquisition using AVR microcontroller and Wireless Sensor Network. Elaborate the scheme. **[10]**

Q5) Attempt any one of the following :

- a) Design and develop Wireless Temperature Indicator using Adriano or LPC2148. Explain the scheme. **[10]**
- b) Design Remote Monitoring and control system with Automatic Irrigation system using GSM-Bluetooth. Use any processor. **[10]**



Total No. of Questions : 5]

SEAT No. :

PA-761

[Total No. of Pages : 2

[5928]-254

M.E. (Instrumentation & Control)

PROCESS INSTRUMENTATION

Control System

(2017 Pattern) (506109) (Semester - II)

Time : 3 Hours]

[Max. Marks : 50

Instructions to the candidates:

- 1) *All questions are compulsory.*
- 2) *Neat diagram must be drawn wherever necessary.*
- 3) *Figures to the right indicate full marks.*
- 4) *Use of electronic pocket Calculator is allowed.*
- 5) *Assume suitable data if necessary.*

Q1) Attempt any two Questions:

- a) The response of system is $y = bx + \frac{dx}{dt}$. Test whether system is linear or non-linear. [5]
- b) Discuss the term Jump Resonance with frequency response curve. [5]
- c) Explain following physical non linearities; Dead zone, Saturation, Friction. [5]

Q2) Attempt any two Questions:

- a) Explain following points related to nonlinear system; [5]
 - i) Stable node
 - ii) Unstable node
 - iii) Saddle point
 - iv) Stable focus
 - v) Unstable focus.
- b) Brief the describing function of saturation nonlinearities. [5]
- c) Elaborate the construction of phase trajectories by delta method. [5]

P.T.O.

Q3) Attempt any two Questions:

- a) Determine a Lyapunov function for the nonlinear system given by [5]

$$\dot{x}_1 = -x_1 \quad \dot{x}_2 = -x_2 + x_1 x_2^2$$

Use variable gradient method.

- b) Consider the nonlinear system [5]

$$\dot{x}_1 = -x_1 - x_2^2 \quad \dot{x}_2 = -x_2$$

Investigate the stability of the equilibrium points.

- c) Check the stability of the system described by [5]

$$\dot{x}_1 = -x_1 + 2x_1^2 x_2$$

$$\dot{x}_2 = x_2$$

Use variable gradient method.

Q4) Attempt any two Questions:

- a) Discuss input state linearization with example. [5]
b) Describe the term zero dynamics with example [5]
c) Illustrate the concept Diffeomorphisms and State Transformations. [5]

Q5) Attempt any one Question:

- a) Elaborate the concept of sliding mode control using Sliding surface, Reachability, Reaching law, chattering effect. [10]
b) Discuss various merits and drawbacks of sliding mode control. [10]



Total No. of Questions : 5]

SEAT No. :

PA-762

[Total No. of Pages : 2

[5928]-255

M.E. (Instrumentation & Control) (Process Instrumentation)
ADVANCED SIGNAL PROCESSINGS
(2017 Pattern) (Semester - III) (606101)

Time : 3 Hours]

[Max. Marks : 50

Instructions to the candidates :

- 1) *All questions are compulsory.*
- 2) *Neat diagrams must be drawn wherever necessary.*
- 3) *Figures to the right side indicates full marks.*
- 4) *Use of electronic pocket calculator.*
- 5) *Assume suitable data, if necessary.*

Q1) Attempt any two questions :

- a) Determine the response of LTI system when input $x(n) = \{1 \ 1 \ 1\}$ and impulse response $h(n) = \{1 \ 2 \ 3\}$. Determine the response of the LTI system by DFT method. [5]
- b) List different types of windows used in FIR filter design, sketch their response and also write their mathematical sequence. [5]
- c) Compute DFT using DIT FFT Algorithm. $x(n) = \{1 \ 1 \ 1 \ 1 \ 1 \ 1 \ 1 \ 1\}$. [5]

Q2) Attempt any two questions :

- a) List different properties of STFT. Explain any two properties. [5]
- b) Write short note on wavelet filter banks. [5]
- c) Compare Up sampling and down sampling of signal. [5]

Q3) Attempt any two questions :

- a) Determine the output $y(n)$ in terms of input $x(n)$ for the mutirate system shown in figure, [5]

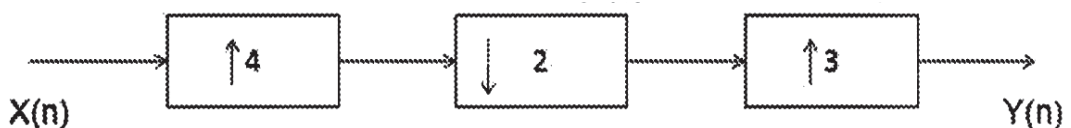

P.T.O.

- b) Consider multirate system as shown in figure, find $y(n)$ as function of $x(n)$. [5]

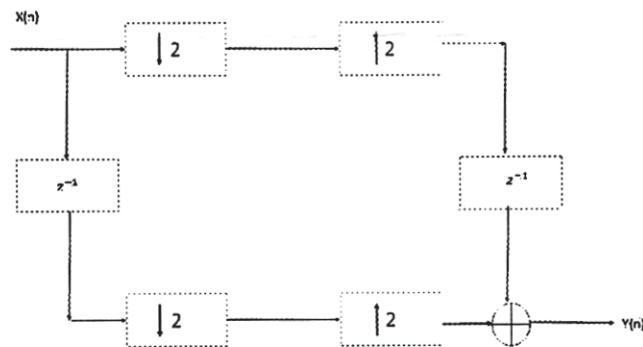

- c) Compare LMS and RLS filters. [5]

Q4) Attempt any two questions :

- a) Write short note on energy spectrum of discrete time signal. [5]
 b) Explain random signals and random process. [5]
 c) Explain MA modeling for power spectrum estimation. [5]

Q5) Attempt any one question :

- a) Determine the frequency resolution, variability and figure of merit of the Bartlett, Welch (50% Overlap) and Blackman Tukey method when $x(n)$ has 800 samples (i.e. $N = 800$) and quality factor is 16 (i.e. $Q = 16$). [10]
 b) Compute period gram of the signal vector, $x(n) = \{1 \ 1 \ 1 \ 1 \ 1 \ 1 \ 1 \ 1\}$ and sketch the period gram. [10]



Total No. of Questions : 7]

SEAT No. :

PA-763

[5928]-256

[Total No. of Pages : 2

M.E. - II (Process Instrumentation & Control)

BUILDING AUTOMATION

(2017 Pattern) (Semester - III) (606102)

Time :3 Hours]

[Max. Marks : 50

Instructions to the candidates:

- 1) *Answer any five questions.*
- 2) *Neat diagram must be drawn whenever necessary.*
- 3) *Figures to the right indicate full marks.*
- 4) *Use of logarithmic tables slide rule, Mollier charts, electronic pocket calculator and steam table is allowed.*
- 5) *Assume suitable data, if necessary.*

Q1) a) Explain with neat sketch building life safety system. **[6]**

b) Write a short notes on Central processing unit of FACP. **[4]**

Q2) a) List various types of reader in biometric access control system. Explain authentication with example. **[6]**

b) Write a short notes on PIDS. **[4]**

Q3) a) Explain Single duct, constant volume, single zone systems Air conditioning system with neat sketch. **[6]**

b) Write a short notes on Air Handling Unit (AHU). **[4]**

Q4) a) What is vapour compression cycle? Explain any one type of evaporator used in vapour compression cycle. **[6]**

b) Write a short notes on Chilled water coil. **[4]**

P.T.O.

Q5) a) Explain features of primary controller and secondary controller in DDC with neat sketch. [6]

b) Write short notes on green building. [4]

Q6) a) Explain different steps in DDC control design process. [6]

b) Write a short notes on BACnet Protocol. [4]

Q7) a) Explain Project Management, what are the characteristics of project. [6]

b) Write a short note on Project Closure & Signoff. [4]



Total No. of Questions: 7]

SEAT No. :

PA-764

[5928]-258

[Total No. of Pages : 2

**M.E. (Mechanical) (Automotive Engineering)
AUTOMOTIVE SAFETY AND REGULATIONS
(2017 Pattern) (Semester-I) (502303)**

Time : 3 Hours]

[Max. Marks : 50

Instructions to the candidates:

- 1) *Answer any five questions*
- 2) *Neat diagrams must be drawn wherever necessary.*
- 3) *Figures to the right indicate full marks.*
- 4) *Use of logarithmic tables, slide rules and electronic pocket calculator is allowed.*
- 5) *Assume suitable data, if necessary.*

- Q1)** a) What do you understand by vehicle safety? What are the objectives of it? List out various provisions of safety aspects incorporated in a modern car? [5]
- b) With suitable sketch describe the design features used on a vehicle structure for protection of occupants in frontal crash. [5]
- Q2)** a) Explain “injury measurement and criteria” for human body undergone with impact during accidents. What is injury rating? Explain. [5]
- b) Explain role for ergonomics in vehicle safety. [5]
- Q3)** a) What are types of automobile seats? Explain with neat sketch construction of front seat? [5]
- b) Explain role of automobile seat anchorage. [5]
- Q4)** a) What is the role of proper lighting and reflecting devices in automobile safety? Name different types of lighting and signaling devices used in modern automobiles? [5]
- b) Name the different types of environments test defined in Indian standards for evolution of lighting and signaling devices, explain them. [5]
- Q5)** a) Describe various passive safety regulations adopted in India as per IS/AIS. [5]
- b) Sketch any three road signs specifying dimensions and color code as per CMVR rule. [5]

P.T.O.

- Q6)** a) Explain the types of safety glasses? What are the requirements of it? [5]
b) What are different types of automobile head lamp designs used in today's cars? Explain with sketch. [5]

- Q7)** Write short notes on the following (Any two) [10]
a) Seat belt system with pre-tensioner in load limiter.
b) Seat belts and its anchorage.
c) Types of rear view mirrors.



Total No. of Questions : 7]

SEAT No. :

PA-1147

[Total No. of Pages : 2

[5928]-259

M.E. (Mechanical - Automotive Engineering)

ENGINE COMBUSTION TECHNOLOGY

(2017 Pattern) (Semester - II) (502307)

Time : 3 Hours]

[Max. Marks : 50

Instructions to the candidates:

- 1) *Answer any five questions.*
- 2) *Neat diagrams must be drawn wherever necessary.*
- 3) *Figures to the right indicate full marks.*
- 4) *Use of scientific calculator is allowed.*
- 5) *Assume Suitable data if necessary.*

Q1) a) What is enthalpy of combustion? How does it differ from the enthalpy of reaction? [5]

b) Volumetric analysis of products of combustion of fuel is as follows
 $\text{CO}_2 = 12.5\%$, $\text{CO} = 0.3\%$, $\text{O}_2 = 5\%$ and rest is N_2 . [5]

Find :

- i) Air fuel ratio
- ii) Fuel composition on mass basis

Q2) a) Explain stratified charge combustion. [5]

b) Explain adiabatic flame temperature. [5]

Q3) a) Explain the stages of combustion in SI engine. [5]

b) What is delay period. What are the different factors which affects delay period. [5]

Q4) a) Give the classification of combustion chambers in CI engine. Explain M combustion chamber. [5]

b) Explain swirl, squish and tumble. [5]

P.T.O.

- Q5)** a) Explain the factors which reduces knocking in SI and CI engine with justification. [5]
b) What are the different methods to control the emission? Explain any one method. [5]
- Q6)** a) Explain the combustion theory applied to gas turbine combustion system. [5]
b) Describe briefly factors affecting combustion chamber design in gas turbine. [5]
- Q7)** Write short notes on (Any two) : [10]
a) Octane number and Cetane Number.
b) Flame tube cooling.
c) First law analysis of reacting system



Total No. of Questions : 8]

SEAT No. :

PA-602

[Total No. of Pages : 2

[5928]-26

M.E. (Civil) (Geotechnical Engineering)
GEOTECHNICAL EARTHQUAKE ENGINEERING
(2017 Pattern) (Semester -III) (601133)

Time : 3 Hours]

[Max. Marks : 50

Instructions to the candidates:

- 1) *Attempt Q1 or Q2, Q3 or Q4, Q5 or Q6 or Q7 or Q8.*
- 2) *Neat diagram must be drawn wherever necessary.*
- 3) *Figures to the right indicate full marks.*
- 4) *Assume suitable data if necessary and clearly state.*
- 5) *Use of cell phone is prohibited in the examination hall.*
- 6) *Use of electronic pocket calculator is allowed.*

Q1) a) Explain Elastic Rebound Theory. [6]

b) Explain 2-d ground response analysis. [7]

OR

Q2) a) Explain the steps for strong motion recording with the help of seismographs. [6]

b) Explain two lab tests, for measurement of Dynamic soil properties. [7]

Q3) a) Discuss 'Effect of local site conditions' on ground motion. [6]

b) Discuss 'Effects of liquefaction'. [6]

OR

Q4) a) Discuss 'Development of design parameter's for ground motion. [6]

b) Explain Evaluation of liquefaction hazards. [6]

Q5) a) Discuss Ground Response Analysis. [6]

b) Explain 'Seismic slope Stability. [6]

OR

P.T.O.

- Q6)** a) Explain Development of deformation analysis by Goodman. [6]
b) Describe types of earthquake which induced landslides. [6]

- Q7)** a) Discuss 'EQ induced settlement'. [7]
b) Discuss 'Seismic Design of Retaining wall'. [6]

OR

- Q8)** a) Explain 'Jai-Krishna' Approach. [7]
b) Explain Development of deformation analysis by seed Approach. [6]



Total No. of Questions : 7]

SEAT No. :

PA-765

[Total No. of Pages : 2

[5928]-260

M.E. (Mechanical) (Automotive Engineering)

NOISE VIBRATION AND HARSHNESS

(2017 Credit Pattern) (Semester - II) (502308)

Time : 3 Hours]

[Max. Marks : 50

Instructions to the candidates:

- 1) *Answer any five questions out of 7.*
- 2) *All the questions should be solved in one answer book and attach extra supplements if required.*
- 3) *Neat diagrams must be drawn wherever necessary.*
- 4) *Use of Calculator is allowed.*
- 5) *Assume Suitable data if necessary, but state the assumptions clearly.*

Q1) a) Describe the different types of accelerometer mounting for vibration measurements. **[5]**

b) Explain the principle of wave propagation. What do you mean by Transverse and Longitudinal sound waves? **[5]**

Q2) A simply supported beam of 1m length and 50 mm in diameter is carrying a mass 100 kg at a distance of 0.25 m from one end. Find the natural frequency of transverse vibrations. Assume Young's modulus of beam material as 250GN/m². **[10]**

Q3) a) Explain the Pass by Noise measurement method for Vehicle. **[5]**

b) Show that as the distance from a point source doubles, the sound intensity level decreases by 6 dB. **[5]**

Q4) a) What are the different methods of noise source identification available?**[5]**

b) Explain the working of sound intensity probe P-P. **[5]**

P.T.O.

Q5) a) Explain effect of noise on human beings. **[5]**

b) Explain the single source structure-borne noise transmission path analysis. **[5]**

Q6) Two machines are working in noisy environments. The background noise when the machines are inoperative is 65 dB. If the two machines having individual sound pressure levels of 84 and 88 dB are switched on simultaneously, determine the combined sound pressure level of the machines along with the background noise. **[10]**

Q7) Describe Impedance tube (Kundt's tube) method (ASTM E1050) using two microphones for evaluating sound absorption coefficient. **[10]**



Total No. of Questions : 7]

SEAT No. :

PA-766

[Total No. of Pages : 2

[5928]-261

M.E. (Mechanical - Automotive Engineering)

AUTOMOTIVE CHASSIS DESIGN

(2017 Pattern) (502309) (Semester - II)

Time : 3 Hours]

[Max. Marks : 50

Instructions to the candidates:

- 1) *Answer any five questions.*
- 2) *Neat diagrams must be drawn wherever necessary.*
- 3) *Figures to the right side indicate full marks.*
- 4) *Assume suitable data if necessary.*

Q1) a) What are various loads acting on suspension system? Explain them with neat sketch. **[5]**

b) Describe role and objectives of suspension system used in automobile. **[5]**

Q2) a) Explain with neat sketch construction and working of shock absorber used in automotive suspension. **[5]**

b) Explain with neat sketch hydro gas suspension system. **[5]**

Q3) a) Explain with neat sketch construction and working of Ackerman Steering System used in automobile. **[5]**

b) Define with neat sketch following terminology related to steering geometry. **[5]**

i) Caster

ii) King pin Inclination.

P.T.O.

- Q4)** a) What is power steering? Describe the working of power steering with neat sketch. [5]
b) Explain with neat sketch construction of disc type wheel. [5]
- Q5)** a) Describe with neat sketch construction of Cross ply tyre used on vehicles. [5]
b) State different materials used for brake liners. Explain concept of stopping distance of vehicle in detail. [5]
- Q6)** a) What do you understand by Hydraulic brake system? Describe with neat sketch working of hydraulic brake system. [5]
b) Describe purpose and applications and of six wheel vehicles. Justify your answer with suitable examples. [5]
- Q7)** Write short note on the following: (Any two) [10]
a) Spring stresses in rigid six wheeler.
b) Wheel specifications and aspect ratio.
c) Servo power assisted brake system.



Total No. of Questions : 7]

SEAT No. :

PA-767

[Total No. of Pages : 2

[5928]-262

M.E. (Mechanical) (Automotive Engineering)

VEHICLE DYNAMICS

(2017 Pattern) (Semester - III) (602313)

Time : 3 Hours]

[Max. Marks : 50

Instructions to the candidates :

- 1) *Answer any five questions.*
- 2) *Figures to the right indicates full marks.*
- 3) *All questions carry equal marks.*
- 4) *Assume suitable data, if necessary.*

Q1) a) Draw the tire axis system as recommended by the SAE and explain various angles and forces associated with the tire. **[4]**

b) A passenger car weighing 15 kN is equipped with the radial-ply tires. The coefficient of rolling resistance of the tire is given by $f_r = 0.0136 + 4 \times 10^{-8} V^2$, where V is the speed of vehicle in kmph. At a speed of 60 kmph, calculate – (i) the power required to overcome rolling resistance of tire and (ii) the retardation rate of car due to rolling resistance of tire when brakes are applied. **[6]**

Q2) a) Discuss the effect of wheel lock up during braking on the directional stability and control of a road vehicle. **[2]**

b) The mass of a passenger car including four tires is 1500 kg. Each of the tires weighs 225 N, has an effective diameter of 67 cm and a radius of gyration of 28 cm. The engine develops a power of 45 kW at 4000 rpm. The equivalent weight of the rotating parts of the driveline is 450 N with a radius of gyration of 10 cm. The transmission efficiency is 88% and the total reduction ratio of the driveline in the second gear is 7.7 to 1. The vehicle has a frontal area of 1.67 m² and the aerodynamic drag coefficient is 0.45. Assume standard atmospheric temperature and pressure condition as 15 °C and 1.013 bar and gas constant for air $R = 287 \text{ J/kg-K}$. The average coefficient of rolling resistance is 0.015. Under these conditions determine -

i) Speed of the car, ii) Aerodynamic resistance to the car and iii) Acceleration of the car on a level road **[8]**

P.T.O.

- Q3)** a) Define reference frame, toe-in, toe-out, wheel camber, caster and kingpin angle with respect to the suspension kinematics. [5]
 b) Explain roll center analysis of vehicle suspension. [5]
- Q4)** a) Write an expression for the steer angle required to negotiate a given curve in case of a two axle road vehicle and define the under-steer coefficient. Describe the various steady-state handling characteristics with the help of this coefficient. (No derivation) [4]
 b) A passenger car weighs 20 kN and has a wheelbase of 2.8 m. The center of gravity is 1.27 m behind the front axle. If a pair of radial-ply tires, each of which has a cornering stiffness of 46 kN/rad are installed in the front, and a pair of bias-ply tires, each of which has a cornering stiffness of 33 kN/rad are installed in the rear. The average steering gear ratio is 22. Determine- (i) Whether the vehicle is understeer or oversteer (ii) the required angle in degrees at steering wheel during a constant radius test with turn radius of 12 m at a constant forward speed of 40 kmph [6]
- Q5)** a) Discuss in detail the effect of natural frequency of sprung mass and damping factor on the performance of vehicle suspension. [4]
 b) The sprung mass of a passenger car weigh 14 kN and the un-sprung parts weigh 8% of sprung mass. When car is stationary the suspension spring and tire deforms by 175 mm and 20mm respectively. Determine i) Vertical stiffness of suspension spring and tire. ii) The two natural frequencies of the bounce motion of the sprung and un-sprung mass. [6]
- Q6)** a) Explain the method of calculating RMS value of the vehicle response when it is excited by the random road profile with known power spectral density. [5]
 b) Write short note on the model of ISO road profile. [5]
- Q7)** a) Explain the effect of wheelbase filtering on the vibration response of vehicle suspension to the road roughness. [5]
 b) Explain various tests that can be used to evaluate handling characteristics of vehicles. [5]



Total No. of Questions : 7]

SEAT No. :

PA-768

[5928]- 263

[Total No. of Pages : 2

M.E. (Mechanical) (Automotive Engineering)

AUTOTRONICS

(2017 Pattern) (Semester - III) (602314)

Time :3 Hours]

[Max. Marks : 50

Instructions to the candidates:

- 1) *Answer any five questions.*
- 2) *Neat diagram must be drawn whenever necessary.*
- 3) *Figures to right indicates full marks.*

Q1) a) Explain the different circuit protective Devices in High Voltage System.[5]

b) Explain how the transistor is used as variable switch in Automotive circuit. [5]

Q2) a) What are voltage generating sensors? Explain hall effect switch used to measure the speed of the monitored component. [5]

b) Explain sequential fuel injection system. [5]

Q3) a) Explain Selective Catalytic Reduction (SCR) system in context with diesel vehicle. [5]

b) Explain VVT (Variable Valve Timing) in context with emission control.[5]

Q4) a) Explain testing a MAP (Manifold Absolute Pressure) sensor. [5]

b) Explain electronic diagnostic equipment for vehicle. [5]

P.T.O.

Q5) a) Explain working of orifice expansion tube with neat sketch. [5]

b) Explain different component in ATC for passenger comfort. [5]

Q6) a) Explain electronic stability program system in vehicle. [5]

b) Explain different components of air bag system. [5]

Q7) Write short notes (Any two)

a) MOSFET technology in Vehicle. [5]

b) Active Control Mounts in vehicle [5]

c) Active Headrest system. [5]

d) Air Bag system Sensor. [5]



Total No. of Questions: 5]

SEAT No. :

PA-769

[5928]-264

[Total No. of Pages : 2

M.E. (Mechanical) CAD Manufacture & Engineering
ADVANCE MACHINE DESIGN
(2017 Pattern) (502402)

Time : 3 Hours]

[Max. Marks : 50

Instructions to the candidates:

- 1) *Solve any two from each question.*
- 2) *Assume suitable data, if necessary.*
- 3) *Figures to the right indicate full marks.*
- 4) *Use of electronic pocket calculator is allowed.*

Q1) Attempt any two

- a) Derive the compatibility equations in Cartesian co-ordinate systems. [5]
- b) Derive the relation between Young's modulus, Bulk modulus and modulus of rigidity in detail. [5]
- c) Investigate the validity of stress function [5]

$$\phi = \left[C_1 r^4 + C_2 r^2 + C_3 + \frac{C_4}{r^2} \right] \cos 2\theta \text{ where } r \text{ and } \theta \text{ are polar coordinates.}$$

Q2) Attempt any two

- a) Explain stress-strain relation for brittle and ductile material. [5]
- b) Explain Mohr's theory of failure in detail. [5]
- c) Explain the following theories of failures with graphical representation and applications [5]
 - i) Octahedral shearing stress theory
 - ii) Maximum elastic strain theory

Q3) Attempt any two

- a) Explain the procedure to estimate the life of the member subjected to creep. [5]
- b) Explain Galerkin's and Raleigh-Ritz methods with its important characteristics. [5]
- c) Following creep data at certain temperature is known [5]
 $S_1 = 10.5 \text{ MPa}$, $\epsilon_1 = 0.012\% \text{ per } 1000\text{hr}$.
 $S_2 = 14 \text{ MPa}$, $\epsilon_2 = 0.025\% \text{ per } 1000\text{hr}$.
Determine the constants of hyperbolic sine law and calculate the creep rates for stress values of 20 MPa and 28 MPa.

P.T.O.

Q4) Attempt any two.

- a) Describe the influence of super imposed static stress in fatigue. [5]
- b) Explain high cycle and low cycle fatigue. [5]
- c) What is the hybrid material and discuss its applications? [5]

Q5) Attempt any two

- a) Explain the Maxwell and Kelving models. [5]
- b) Describe transverse shear effect in composite laminates. [5]
- c) Explain the concept of energy balance during crack growth. [5]



Total No. of Questions: 8]

SEAT No. :

PA-770

[5928]-265

[Total No. of Pages : 1

**M.E. (Mechanical) (CAD, M&E)
COMPUTER AIDED DESIGN
(2017 Pattern) (Semester-I) (502403)**

Time : 3 Hours]

[Max. Marks : 50

Instructions to the candidates:

- 1) *Answer any five questions.*
- 2) *Neat diagram must be drawn wherever necessary.*
- 3) *Use of non-programmable calculator is allowed.*
- 4) *Assume suitable data, if necessary.*

- Q1)** a) Explain the CAD/CAM system evaluation criteria in brief [5]
b) Discuss with neat sketches explain wire frame entities [5]
- Q2)** a) Explain Geometric constraints and Datum Plane with suitable example [5]
b) Discuss the surface representation [5]
- Q3)** a) Explain the Parametric representation of plane surface with neat sketch. [5]
b) Explain Feature based modeling [5]
- Q4)** Explain the Surface manipulations techniques [10]
- Q5)** a) An entity is rotated about the three principal axes of in MCS with equal angles of 45° each. Find the equivalent axis and angle of rotation. [5]
b) Explain the approaches used for creating an assembly [5]
- Q6)** a) Explain datum feature with suitable example [5]
b) Describe techniques of visual realism [5]
- Q7)** a) Explain STEP Architecture with the help of neat block diagram [5]
b) Explain the need for CAD/CAM Data Evaluation [5]
- Q8)** a) Explain the tolerance modeling concepts used in CAD [5]
b) Explain, how collaborative product design enhances the productivity [5]



Total No. of Questions :7]

SEAT No. :

PA-771

[5928]- 267

[Total No. of Pages :1

M.E. Mechanical (Computer Aided Design, Manufacture & Engineering)

INDUSTRIAL PRODUCT DESIGN & PRODUCT LIFE CYCLE MANAGEMENT

(2017 Pattern) (Semester - II) (502408)

Time : 3 Hours]

[Max. Marks : 50

Instructions to the candidates:

- 1) Answer any 5 questions from the following.*
- 2) Neat diagrams must be drawn wherever necessary.*
- 3) Figures to the right side indicate full marks.*
- 4) Assume suitable data if necessary.*

Q1) Explain challenges in new product development with example. [10]

Q2) Detail about process of concept generation with technique involve in it. [10]

Q3) Explain break even analysis & its importance? [10]

Q4) Explain PLM strategy to develop product data & product workflow in PLM. [10]

Q5) What are threads of PLM? Explain in details. [10]

Q6) What is the impact of integration of PLM & CAD. [10]

Q7) State & explain PDM functions. [10]



Total No. of Questions : 8]

SEAT No. :

PA-772

[Total No. of Pages : 2

[5928]-268

M.E. (Mechanical) (CADME)

**AUTOMATED MANUFACTURING SYSTEM
MODELLING**

(2017 Pattern) (502409) (Semester - II)

Time : 3 Hours]

[Max. Marks : 50

Instructions to the candidates:

- 1) *Answer any five questions.*
- 2) *Neat diagram must be drawn wherever necessary.*
- 3) *Use of Non - programmable Calculator is allowed.*
- 4) *Assume suitable data if necessary.*

Q1) a) Enlist principles of automation. [5]

b) Explain what is programmable logic controllers. [5]

Q2) a) Explain the concept of automation productivity and its need. [5]

b) Differentiate between GT and Cellular Manufacturing. [5]

Q3) A machine tool builder submits a proposal for a 20-station transfer line to machine a certain component currently produced by conventional methods. The proposal states that the line will operate at a production rate of 50 pieces per hour at 100% efficiency. On similar transfer lines, the probability of station breakdowns per cycle is equal for all stations and $p = 0.005$ breakdowns/ cycle. It is also estimated that the average downtime per line stop will be 8.0 min. The starting casting that is machined on the line costs \$3.00 per part. The line operates at a cost of \$75.00/hr. The 20 cutting tools (one tool per station) last for 50 parts each, and the average cost per tool Based on this data, compute (a) production rate, and (b) line efficiency.

[5]

P.T.O.

- Q4)** Explain any one logic device used in Hydraulic circuits. Explain the steps used for developing pneumatic circuits for automatic die casting machine. [5]
- Q5)** a) Explain the need for system Modeling of Manufacturing Plant Automation. [5]
b) Explain the application of Artificial neural networks in manufacturing automation with suitable example. [5]
- Q6)** a) Enlist and explain the advantages of non-contact type of Inspection over Contact. [5]
b) Explain the basic components of CMM. [5]
- Q7)** a) Enlist the methods of Gathering the data for plant Automation and explain any one in detail. [5]
b) Write short notes on Queues. [5]
- Q8)** Explain continuous - time Markov chain with an example. [10]



Total No. of Questions : 7]

SEAT No. :

PA-2900

[Total No. of Pages : 2

[5928]-269

M.E. (Mechanical) (CADM & E)

SIMULATION MODELING

(2017 Pattern) (Semester - III) (602413)

Time : 3 Hours]

[Max. Marks : 50

Instructions to the candidates:

- 1) *Answer the five questions from following.*
- 2) *Near diagram must be drawn whenever necessary.*
- 3) *Figures to the right indicate full marks.*
- 4) *Assume suitable data, if necessary.*

Q1) Explain the following terms : **[10]**

- a) Explain the simulation procedure of continuous system.
- b) Explain the Triangular Distribution.

Q2) Explain the following terms : **[10]**

- a) System & System environment.
- b) *Components of a system.*
- c) Stochastic nature of output data.

Q3) List the areas of applications related to simulation modeling. And list the limitations of simulation. **[10]**

Q4) Explain Poisson Distribution. **[10]**

Q5) Discuss in detail Weibull distribution and Empirical continuous distribution. **[10]**

P.T.O.

Q6) Explain Linear congruential method with example.

[10]

Q7) Define Modeling of System Randomness. Explain various sources of Randomness and their effect on Machine Downtime.

[10]



Total No. of Questions : 8]

SEAT No. :

PA-603

[Total No. of Pages : 2

[5928]-27

M.E. (Civil) (Geotechnical Engineering)
RESEARCH METHODOLOGY
(2017 Pattern) (Semester - III) (601134)

Time : 3 Hours]

[Max. Marks : 50

Instructions to the candidates:

- 1) *Answer Q.1 or Q.2, Q.3 or Q.4, Q.5 or Q.6, Q.7 or Q.8.*
- 2) *Neat diagrams must be drawn wherever necessary.*
- 3) *Figures to the right side indicate full marks.*
- 4) *Assume suitable data if necessary and clearly state.*

Q1) a) Describe any two types of research. [5]

b) What do you mean by literature survey? Explain its need. [4]

OR

Q2) a) Write short note on objectives of literature survey and different sources of literature. [5]

b) Enlist steps involved in a research process. [4]

Q3) a) What is a hypothesis? Explain basic concepts concerning testing of hypothesis. [5]

b) Explain the criteria of goodness of a measurement scale. [4]

OR

Q4) a) Explain the meaning of analysis of variance. Describe briefly the technique of analysis of variance. [5]

b) Differentiate collection of data through questionnaires and schedules. [4]

P.T.O.

- Q5)** a) Explain in detail correlation and regression analysis. [8]
b) Explain in brief multidimensional scaling and measurement. [8]

OR

- Q6)** a) Write a short note of discriminant and cluster analysis. [8]
b) Write a note on Factor Analysis. [8]

- Q7)** a) Explain in brief various aspects to be considered by research student in written and oral presentation of research report. [8]
b) Explain in detail the form at used for writing proposals. Also state the difference between a journal and conference paper. [8]

OR

- Q8)** a) Explain the significance of a research report. [8]
b) Write a note on “Patenting a research idea”. [8]



Total No. of Questions : 7]

SEAT No. :

PA-773

[5928]- 270

[Total No. of Pages : 2

**M.E. (Mechanical) (Computer Aided Design Manufacture
& Engineering)**

**OPTIMIZATION TECHNIQUES
(2017 Pattern) (Semester - III) (602414)**

Time :3 Hours]

[Max. Marks : 50

Instructions to the candidates:

- 1) *Answer any five questions.*
- 2) *Figures to the right indicates full marks.*
- 3) *Assume suitable data, if necessary.*

Q1) a) How do you define Optimization Problem? Give mathematical definition and example? **[5]**

b) How find the dimensions of a box of largest volume that can be inscribed in a sphere of unit radius. **[5]**

Q2) Maximize $F = x_1 + 2x_2 + x_3$ **[10]**

Subject to

$$\begin{aligned} 2x_1 + x_2 - x_3 &\leq 2 \\ -2x_1 + x_2 - 5x_3 &\geq -6 \\ 4x_1 + x_2 + x_3 &\leq 6 \\ x_i &\geq 0, i = 1, 2, 3 \end{aligned}$$

Q3) Determine the maximum and minimum values of the function **[10]**

$$f(x) = 12x^5 - 45x^4 + 40x^3 + 5$$

Q4) Write a short note on (Any 2): **[10]**

- a) Genetic Algorithm.
- b) Neural-Network.
- c) Simulated Annealing
- d) Fuzzy Optimization

P.T.O.

Q5) Find the value of x in the interval $[0,3]$ using Golden Section Method up to six iterations. **[10]**

$$F(x) = 0.65 - [0.75/(1+x^2)] - 0.65 x \tan^{-1} (1/x)$$

Q6) Explain following:

a) ESO for stress level optimization **[5]**

b) ESO for stiffness optimization **[5]**

Q7) a) Explain how topology optimization can be used as a design tool with an example. **[5]**

b) Write a short note on Bidirectional Evolutionary Optimization Method. **[5]**



Total No. of Questions : 7]

SEAT No. :

PA-774

[Total No. of Pages : 2

[5928]-271

M.E. (Mechanical) (Energy Engineering)

ADVANCED THERMODYNAMICS

(2017 Pattern) (Semester - I) (502502)

Time : 3 Hours]

[Max. Marks : 50

Instructions to the candidates:

- 1) *Solve any five questions.*
- 2) *Neat diagram must be drawn whenever necessary.*
- 3) *Figures to the right indicate full marks.*
- 4) *Use of steam tables, Mollier charts, scientific calculator is allowed.*
- 5) *Assume suitable data, if necessary.*

- Q1)** a) Define the reduced pressure and reduced temperature and explain the Law of corresponding states. [5]
- b) Discuss the Amagat's Law and Kay's Rule. [5]
- Q2)** a) On Mollier diagram, why do the isobars diverge from one another. [5]
- b) Draw the phase equilibrium diagram for a pure substance on P-T co-ordinates. Why does the fusion line for water have negative slope? [5]
- Q3)** a) Explain the principle of increase of entropy. [4]
- b) The radiator of a steam heating system has a volume of 20L and is filled with superheated water vapour at 200kPa and 150°C. At this moment both the inlet and the exit valves to the radiator are closed. After a while the temperature of the steam drops to 40°C as a result of heat transfer to the room air. Determine the entropy change of the system during this process. [6]

P.T.O.

- Q4)** a) Explain the following terms [6]
 i) Dead state
 ii) Lost work
 b) Derive Maxwell relations. [4]

- Q5)** a) With usual notations derive the following thermodynamics relation. [5]

$$C_p - C_v = \frac{T\alpha^2}{\beta K_T}$$

- b) Derive Clapeyron equation. [5]
- Q6)** a) Explain the enthalpy of formation and enthalpy of combustion. [4]
 b) Hydrogen (H₂) is burned completely with the stoichiometric amount of air during a steady flow combustion process. If both the reactants and the products are maintained at 25°C and 1 atm and the water in the products exists in the liquid form, determine the heat transfer from the combustion chamber during this process. What would your answer be if combustion were achieved with 50% excess air? Take. [6]

Substance	h _f kJ/kmol
H ₂	0
O ₂	0
N ₂	0
H ₂ O(l)	-285830

- Q7)** Write notes on (any two) : [10]
 a) Fugacity and Activity
 b) The criteria for chemical equilibrium.
 c) Dalton's law of Partial pressure.



Total No. of Questions : 8]

SEAT No. :

PA-2612

[Total No. of Pages : 2

[5928]-272

**M.E. (Mechanical - Energy Engineering)
NON-CONVENTIONAL ENERGY SOURCES
(2017 Pattern) (Semester - I) (502503)**

Time : 3 Hours]

[Max. Marks : 50

Instructions to the candidates:

- 1) *Answer any five questions.*
- 2) *Neat diagrams must be drawn wherever necessary.*
- 3) *Figures to the right indicate full marks.*
- 4) *Use of non programmable calculator is allowed.*
- 5) *Assume suitable data if necessary.*

- Q1)** a) What are the renewable energy sources? Describe briefly. [5]
b) Explain in brief world energy scenario? [5]
- Q2)** a) Explain with neat diagram the working of any one type of solar collector. [6]
b) Write a note on: [4]
i) Solar pumping
ii) Solar applications
- Q3)** a) "Sun is major source of all types of energy". Justify. [5]
b) Enumerate the basic principle of wind energy. [5]
- Q4)** a) Explain turbine theory for hydroelectric system? [5]
b) What is meant by anaerobic digestion? Explain factors affecting it? [5]
- Q5)** a) Discuss Geothermal energy generation in India. [5]
b) What are the main types of OTEC power plants? Describe working of OTEC? [5]

P.T.O.

- Q6)** a) Write a short note on wave energy? [5]
b) Discuss the best method of tidal power generations. [5]
- Q7)** a) What is the scope of hybrid energy systems? [2]
b) How are Gasifiers classified? What is Pyrolysis? [4]
c) Explain Bio mass-Diesel system. [4]
- Q8)** Write a short notes on any two: [10]
a) Fossil fuel reserves in India
b) Flat Plate collectors
c) Types of Wind mills



Total No. of Questions : 7]

SEAT No. :

PA-775

[Total No. of Pages : 4

[5928]-273

M.E. (Mechanical-Energy Engineering)
ADVANCED HEAT TRANSFER
(2017 Pattern) (Semester - II) (502507)

Time : 3 Hours]

[Max. Marks : 50

Instructions to the candidates:

- 1) *Attempt Any Five Questions.*
- 2) *Neat diagrams must be drawn wherever necessary.*
- 3) *Figures to right of each question indicate full marks.*
- 4) *Assume suitable data wherever necessary and mention the same clearly.*
- 5) *Use of steam tables, Mollier chart and calculator is allowed.*

Q1) a) Elaborate following in brief : **[5]**

- i) Effect of variation of temperature on thermal conductivity of metals.
 - ii) Effect of variation of temperature on thermal conductivity of non-metals.
- b) How center temperature and temperature at a specified depth is determined with the help of Heisler and Grober charts? **[5]**

Q2) Derive Three Dimensional Heat Conduction Equation in Cartesian Coordinates with Unsteady State and Heat Generation for Anisotropic material and deduce it to **[10]**

- i) 1-D Fourier Equation in x coordinate
- ii) 2-D Laplace Equation in x and y coordinate
- iii) 1-D Poisson's Equation in z coordinate

Write Derive Three Dimensional Heat Conduction Equation in Polar and Cylindrical Coordinates.

P.T.O.

Q3) a) Experimental results for the local heat transfer coefficient h_x for flow over a flat plate with an extremely rough surface were found to fit the relation $h_x(x) = x^{-0.1}$ where $x(m)$ is the distance from the leading edge of the plate. Develop an expression for the ratio of the average heat transfer coefficient for a plate of length x to the local heat transfer coefficient h_x at x . [5]

- b) Write note on : [5]
- Reynolds analogy
 - Chilton-Colburn analogy

Q4) a) Explain physical significance of following dimensionless numbers. [5]

- Peclet Number
 - Stanton Number
 - Rayleigh Number
- b) Water enters a tube with fully developed velocity and uniform temperature of 20°C. The inside diameter of the tube is 4 cm and its length is 9 m. It is desired to heat the water to 60°C by maintaining the surface at 90°C uniform temperature. Determine the mass flow rate to satisfy the above condition. Take $k = 0.64 \text{ W/m } ^\circ\text{C}$, $\nu = 0.62 \times 10^{-6} \text{ m}^2/\text{s}$, $\rho = 995 \text{ kg/m}^3$, $C_p = 4187 \text{ KJ/kg } ^\circ\text{C}$, $\beta = 4.25 \times 10^{-4} \text{ per degree Kelvin}$ [5]

Use following correlations

$$\text{Nu} = 0.023 \text{ Re}_d^{0.8} \text{Pr}^{0.4}.$$

Q5) a) Explain with significance: Velocity Boundary layer & Thermal Boundary Layer. How thickness of VBL and thickness TBL are correlated with Prandtl number? [5]

- b) Draw natural convection current and identify characteristic length in case of following : [5]
- Vertical Cold plate
 - Vertical Hot plate
 - Horizontal plate with hot surface facing up
 - Horizontal plate with hot surface facing down
 - Horizontal cylinder

- Q6)** a) Explain with neat sketch different regimes of pool boiling curve. [5]
- b) The steam at 165°C condenses in the shell side of a heat exchanger over the tubes through which water flows. Water enters the 4cm-diameter, 14-m-long tubes at 20°C at a rate of 0.8 kg/s. Determine the exit temperature of water and the rate of condensation of steam. Take fluid properties at 85°C and latent heat of steam as 2066.5 kJ/kg [5]

Use following correlations

$$\text{Nu} = 4.6 \quad \text{for laminar flow, Constant heat flux}$$

$$\text{Nu} = 3.66 \quad \text{for laminar flow, Constant wall temperature}$$

$$\text{Nu} = 0.023 \text{Re}_d^{(0.8)}\text{Pr}^{(0.4)} \quad \text{for turbulent flow, Constant heat flux or wall temp}$$

- Q7)** a) What is view factor? What are different laws of evaluation of view factor? [5]
- b) What do you mean by radiation shield? Derive expression for the same. [5]

Figure 1: Physical Properties of Air (1 atm)

t °C	ρ kg/m ³	c_p kJ/kgK	$k \times 10^2$ W/mK	$\alpha \times 10^4$ m ² /hr	$\mu \times 10^2$ kg/hr-m	$\nu \times 10^6$ m ² /s	Pr –
10	1.247	1.005	2.511	7.22	6.346	14.16	0.705
20	1.205	1.005	2.592	7.71	6.533	15.06	0.703
30	1.165	1.005	2.673	8.23	6.717	16.00	0.701
40	1.128	1.005	2.755	8.75	6.904	16.96	0.699
50	1.093	1.005	2.824	9.29	7.067	17.95	0.698
60	1.060	1.005	2.894	9.79	7.221	18.97	0.696
70	1.029	1.009	3.045	10.28	7.523	21.09	0.692
80	1.000	1.009	3.045	10.87	7.523	21.09	0.692
90	0.972	1.009	3.127	11.48	7.701	22.10	0.690
100	0.946	1.009	3.208	12.11	7.880	23.13	0.688
120	0.898	1.009	3.336	13.26	8.170	25.45	0.686
140	0.854	1.013	3.487	14.52	8.479	27.80	0.684
160	0.815	1.017	3.638	15.80	8.786	30.08	0.682
180	0.779	1.022	3.778	17.10	9.070	32.49	0.681
200	0.746	1.026	3.929	18.49	9.380	34.85	0.680

Figure 2: Physical Properties of Water (Liquid state)

t °C	ρ kg/m ³	c_p kJ/kgK	$k \times 10^2$ W/mK	$\alpha \times 10^4$ m ² /hr	$\mu \times 10^2$ kg/hr-m	$\nu \times 10^6$ m ² /s	Pr –
0	999.9	4.212	55.093	4.71	644.093	1.789	13.67
10	999.7	4.191	57.418	4.94	469.818	1.306	9.54
20	998.2	4.183	59.859	5.16	361.892	1.006	7.02
30	995.7	4.174	61.718	5.35	288.668	0.805	5.42
40	992.2	4.174	63.345	5.51	235.602	0.659	4.31
50	988.1	4.178	64.740	5.65	197.771	0.556	3.54
60	983.2	4.178	65.902	5.78	169.305	0.478	2.98
70	977.8	4.187	66.716	5.87	146.370	0.415	2.55
80	971.8	4.195	67.413	5.96	127.924	0.365	2.21
90	965.3	4.208	67.995	6.03	113.507	0.326	1.95
100	958.4	4.220	68.227	6.09	101.910	0.295	1.75



Total No. of Questions : 8]

SEAT No. :

PA-1150

[Total No. of Pages : 2

[5928]-274

M.E. Mechanical (Energy Engineering)
ENERGY CONVERSION AND ENVIRONMENT
(2017 Pattern) (Semester - II) (502508)

Time : 3 Hours]

[Max. Marks : 50

Instructions to the candidates:

- 1) *Answer any five questions.*
- 2) *Neat diagrams must be drawn wherever necessary.*
- 3) *Figures to the right indicate full marks.*
- 4) *Use of calculator is allowed.*
- 5) *Assume Suitable data if necessary.*

Q1) a) Explain energy conversion. [4]

b) Explain renewable and non-renewable energy sources. [6]

Q2) The following particulars refer to a stage of a Parson's steam turbine comprising one ring of fixed blades and one ring of moving blades; Mean diameter of blade ring = 75cm, R.P.M. = 3500, Steam velocity at exit of the blades 170m/s, Blade outlet angle = 20°, Steam flow through blades = 8kg/s. [10]

Draw the velocity diagram and find the following:

- a) Blade inlet angle
- b) Tangential force on the ring of moving blades
- c) Power developed in a stage

Q3) a) Explain different approaches of lean burning in IC Engines. [4]

b) Explain Energy Saving Opportunities in Cooling Towers. [6]

Q4) a) Explain suitability of compressor for different applications. [5]

b) Explain heat pump with example. [5]

P.T.O.

Q5) a) Explain the operating principle of a waste heat recovery boiler with example. [5]

b) Explain heat pump with neat sketch. [5]

Q6) a) Describe merits and demerits Diesel power plants. [4]

b) Explain centrifugal compressor with neat sketch used in refrigeration system. [6]

Q7) Explain in detail Reheat and intercooling methods for improvement of the efficiency of gas turbine power plant with cycle analysis. [10]

Q8) Write a short note on the following : [10]

a) Impulse Turbines

b) Reaction Turbine



[5928]-275

M.E. (Mechanical) (Energy Engg.)
ADVANCED FLUID MECHANICS
(2017 Pattern) (Semester - II) (502509)

Time : 3 Hours]

[Max. Marks : 50

Instructions to the candidates:

- 1) Answer five questions from following.
- 2) Draw Diagrams wherever necessary.
- 3) Use of scientific calculator is allowed.
- 4) Assume suitable data where ever necessary

Q1) a) Derive an expression for conservation of mass and momentum using integral analysis. [5]

- b) Consider steady constant density flow over a flat plate as shown in fig. [5]

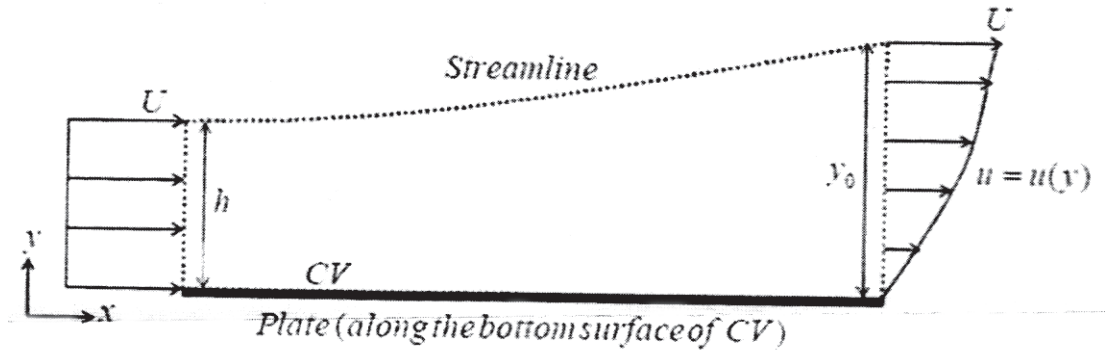

Show that the drag force on the plate is $F_D = \int_0^{y_0} \rho u(U - u) dy$

Q2) What is Stokes first problem, obtain the solution of velocity ($u = u(y, t)$) at any point in the fluid at time 't' for an infinite, incompressible fluid resting on a flat horizontal plate located at $y = 0$ and stretching to infinity in each direction.

At time $t = 0$ the plate is given a velocity zero. Use similarity variable $\eta = \frac{y}{\sqrt{\nu t}}$ [10]

P.T.O.

Q3) a) Steel sphere of 4 mm dia. falls in glycerine at a terminal velocity of 0.04 m/s. Assuming Stokes law is applicable, determine [5]

i) Dynamic viscosity of glycerine

ii) Drag force, and

iii) Drag coefficient for the sphere

Take sp. wt. of steel and glycerine as 75 kN/m³ and 12.5 kN/m³.

b) Obtain exact solution of Couette flow. [5]

Q4) a) Obtain an expression for stream function and velocity function for following flows. Also determine pressure distribution in sink flow. [5]

i) Source & sink flow

ii) Vortex flow

b) A 300 mm diameter circular cylinder is rotated about its axis in a stream of water having a uniform velocity of 5 m/s. Estimate the rotational speed when both the stagnation points coincide. Estimate the lift force experienced by the cylinder under such condition. Density of water may be assumed to be 1000 kg/m³ [5]

Q5) a) State the boundary layer theory assumptions. Obtain boundary layer equations in nondimensionalized form. [5]

b) Using Karman momentum integral equation calculate the local skin friction coefficient C_f for the following velocity profiles on a flat plate

$$\frac{u}{U_\infty} = \frac{3}{2}\eta - \frac{1}{2}\eta^3. \text{ where } \eta = y/\delta \quad [5]$$

Q6) a) Explain different types of free turbulent flows. What is a need of turbulence modeling? [5]

b) Air ($\rho=1.23 \text{ kg/m}^3$ and $\nu = 1.5 \times 10^{-5} \text{ m}^2/\text{s}$) is flowing over a flat plate. The free stream speed is 15 m/s. At a distance of 1m from the leading edge, calculate δ and τ_w for a) completely laminar flow and b) completely turbulent flow for a 1/7th power law velocity profile.

For Laminar flow $\frac{u}{U_\infty} = 2\eta - \eta^2$; when $\eta = y / \delta$ [5]

- Q7)** a) Develop area- velocity relationship in terms of Mach number and discuss effect of variation of area of subsonic, sonic and supersonic flows. [5]
- b) Air flowing isentropically through a converging nozzle discharges to the atmosphere. At any section where the absolute pressure is 179 kPa, the temperature is given by 39°C and the air velocity is 177 m/s. Determine the nozzle throat pressure. [5]



Total No. of Questions : 8]

SEAT No. :

PA-2613

[Total No. of Pages : 2

[5928]-276

M.E. (Mechanical) (Energy Engg.)

ENERGY MANAGEMENT

(2017 Pattern) (Semester - III) (602513)

Time : 3 Hours]

[Max. Marks : 50

Instructions to the candidates:

- 1) *Answer any five questions*
- 2) *Neat diagrams must be drawn wherever necessary.*
- 3) *Figures to the right indicate full marks*
- 4) *Use of electronic pocket calculator is allowed.*
- 5) *Assume suitable data, if necessary.*

Q1) a) Explain the Need of Energy Management System. [5]

b) Explain the various types of sources of energy in world energy market. [5]

Q2) a) What are the managerial functions involved in energy management. [5]

b) Discuss the types of Energy Audit briefly. [5]

Q3) a) What are the goals of HVAC system? [5]

b) List a few types of air conditioning systems in use. [5]

Q4) a) Write note on thermal fluids. [5]

b) What are the methods of condensate heat recovery? [5]

Q5) a) What are the Emerging Technologies for Waste Heat Recovery? [5]

b) Discuss the need of Waste heat recovery. [5]

P.T.O.

Q6) a) What is power factor and what are the effects of power factor Improvement. [5]

b) What are the types of commonly used lamps? [5]

Q7) a) What is steam trap? List various types of steam traps. [5]

b) Explain Energy Audit Procedure. [5]

Q8) Write a short note on (any two). [10]

a) Shell and tube heat exchangers

b) Waste Heat recovery

c) Electrical measurements



Total No. of Questions : 7]

SEAT No. :

PA-2903

[Total No. of Pages : 2

[5928]-277

M.E. (Mechanical) (Energy Engineering)
ENERGY SYSTEMS MODELING AND OPTIMIZATION
(2017 Pattern) (Semester - III) (602514)

Time : 3 Hours]

[Max. Marks : 50

Instructions to the candidates :

- 1) *Answer any five questions.*
- 2) *Neat diagrams must be drawn wherever necessary.*
- 3) *Figures to the right indicates full marks.*
- 4) *Use of scientific calculator is allowed.*
- 5) *Assume suitable data, if necessary.*

- Q1)** a) Explain the types of system study. [6]
b) Explain various types of simulation models for system study. [4]

- Q2)** a) Explain Information Flow Diagram with suitable example. [5]
b) Find the root of equation $x \cdot \log_e x = 1.2$ using Modified Newton-Raphson Iteration Criteria. Take three iterations. Assume initial guess = 2 [5]

- Q3)** a) A person wants to decide the constituents of a diet which will fulfil his daily requirements of protein, fats and carbohydrates at minimum cost. The choice is to be made from different types of foods. The yields per unit of these foods are given below in the table. [5]

Food type	Yield per unit			Cost per
	Proteins	Fats	Carbohydrates	Unit
1	3	2	6	45
2	4	2	4	40
3	8	7	7	85
4	6	5	4	65
Minimum Requirement	800	200	700	

Formulate the linear programming model for the problems.

- b) Maximize $f(x) = 6x - x^2$. Use 1-Dimensional search procedure. Take initial upper and lower bounds 4.8 and 0 respectively and tolerance error is 0.04. [5]

P.T.O.

Q4) Attempt any two : **[10]**

- a) For common heat exchangers, such as the parallel and counter flow heat exchangers shown in Figure 1.5, discuss the development of a simple mathematical model to analyze the system.
- b) Explain different steps in model development.
- c) Maximize: $Z = 2x_1 + x_2$. By using Graphical Method.
Subject to : $x_1 + 2x_2 \leq 10, x_1 + x_2 \leq 6, x_1 - x_2 \leq 2, x_1 - 2x_2 \leq 1, x_1, x_2 \geq 0$

Q5) a) Maximize $f(x) = 20x - 3x^2 - x^4$ by using 1-Dimensional search procedure. **[5]**

- b) The objective function for an optimization problem is taken as the total income, which involves an income of five units on item A and seven units on item B. The former requires 2.5 hours of cutting and 1.5 hours of polishing, whereas item B requires 4 hours of cutting and 1 hour of polishing. If the total labor hours available for cutting are 4000 and for polishing 2000, formulate the optimization problem and solve it by the simplex algorithm to obtain the optimum. **[5]**

Q6) a) Solve the following differential equation using Euler's method under the boundary conditions $x = 1.3$ and $y = 2$. Find y at $x = 1.8$ in 10 steps **[6]**

$$\frac{dy}{dx} = \frac{(x + y)}{(y^2 - \sqrt{xy})}$$

- b) Use the RK second order methods to estimate $y(0.2)$ of the following equation with $h = 0.1, y'(x) = x + y, y(0) = 1$. **[4]**

Q7) a) Use RK fourth order methods to estimate $y(0.2) y(0.4)$ when $y'(x) = 1 + y^2$ with $y(0) = 0$ when $x = 0$. Take step size 0.2. **[5]**

- b) Discuss various types of Thermal Systems and explain any one optimization problems in brief. **[5]**



Total No. of Questions : 08]

SEAT No. :

PA-4459

[Total No. of Pages : 2

[5928]-278

M.E. (Mechanical-Mechatronics)

SYSTEM MODELLING, IDENTIFICATION AND
SIMULATION

(2017 Pattern) (Semester - I) (502801)

Time : 3 Hours]

[Max. Marks : 50

Instructions to the candidates:

- 1) Answer any five questions.
- 2) Neat diagram must be drawn wherever necessary.
- 3) Figures to the right indicate full marks.
- 4) Use of calculator is allowed.
- 5) Assume suitable data, if necessary.

- Q1)** a) Explain the difference between modeling in the time and frequency domain. [5]
- b) Discuss the use of force/torque balance in the EOM of mechanical systems. [5]
- Q2)** a) Describe the process of linearization of non-linear systems using graphical approach. [5]
- b) Define Eigen value and Eigen vector and their importance in modeling of MDOF systems. [5]
- Q3)** a) List the advantages and the disadvantages of the state space modelling approach. [5]
- b) Draw the signal flow diagram for below transfer function. [5]

$$\frac{C(s)}{R(s)} = \frac{(s+3)}{(s^2+10s+24)}$$

P.T.O.

- Q4)** a) Write the generic state space model of a MDOF system in Diagonal form and discuss the advantages of the said form. [5]
 b) Find transfer function from following signal flow graph. [5]

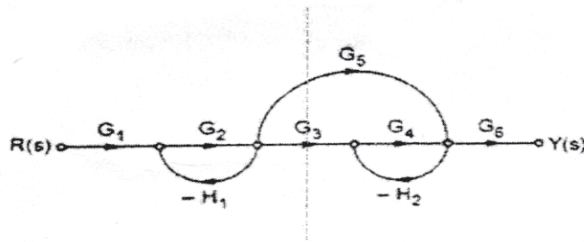

- Q5)** a) Write five exclusive points of comparison between transfer function and state space modelling approach. [5]
 b) Using the Lagrangian approach, determine the EOM of mechanical system. [5]

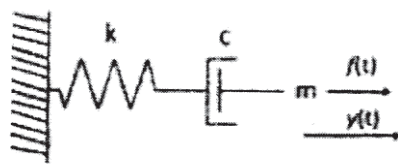

- Q6)** a) List any three state space forms for a MDOF system and discuss their advantages. [5]
 b) Explain in detail the selection process associated with fuzzy membership functions. [5]

- Q7)** a) Draw the flow chart, and explain the working of Unscented Kalman Filter. [5]
 b) Draw the flow chart and explain the identification process using the Least Square method. [5]

- Q8)** a) Draw the bond graph for the electrical system shown in figure given. [5]

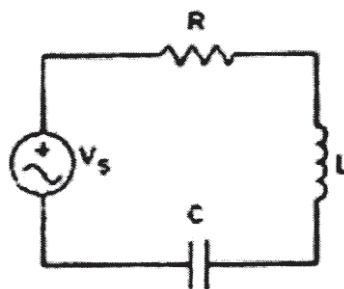

- b) Identify a straight line model for below dataset. [5]

x	8	2	11	6	5	4	12	9	6	1
y	3	10	3	6	8	12	1	4	9	14



[5928]-279
M.E. (Mechanical-Mechatronics)
CONTROL SYSTEM - I
(2017 Pattern) (Semester - I) (502802)

Time : 3 Hours]

[Max. Marks : 50

Instructions to the candidates:

- 1) Answer any five questions.
- 2) Neat diagram must be drawn wherever necessary.
- 3) Figures to the right indicate full marks.
- 4) Use of calculator is allowed.
- 5) Assume suitable data, if necessary.

Q1) Consider the system described by

$$\dot{x}(t) = \begin{bmatrix} 0 & 1 \\ -2 & -3 \end{bmatrix} x(t)$$

Where $x(t) = [x_1(t) \ x_2(t)]^T$

- a) Compute the state transition matrix $\Phi(t,0)$. [5]
- b) Using the state transition matrix from (a) and for the initial conditions $x_1(0) = 1$ and $x_2(0) = -1$, find the solution $x(t)$ for $t \geq 0$. [5]

- Q2)** a) Explain the Routh-Hurwitz Stability Criterion with example. [5]
- b) Discuss the design of an LQR type control. [5]

$$\begin{bmatrix} \dot{x}_1 \\ \dot{x}_2 \end{bmatrix} = \begin{bmatrix} -3.96 & -3.42 \\ 1 & 0 \end{bmatrix} \begin{bmatrix} x_1 \\ x_2 \end{bmatrix} + \begin{bmatrix} 1 \\ 0 \end{bmatrix} u$$

$$y = [407 \ 372.8] \begin{bmatrix} x_1 \\ x_2 \end{bmatrix} + [0] u$$

- Q3)** a) What is the phase variable canonical form in flow graph state model and the block diagram model? [5]
 b) Explain second-order system observer design using Ackermann's formula. [5]
- Q4)** a) Why does full state feedback control require a system to be observable as well as controllable? Explain. [4]
 b) Explain Effect of Feedback on Overall Gain. [6]
- Q5)** a) Explain Quadratic Poles and Zeros with example. [6]
 b) What is controllability canonical form (CCF)? [4]
- Q6)** A system has a block diagram as shown in Figure. Determine a state variable model and the state transition matrix. [10]

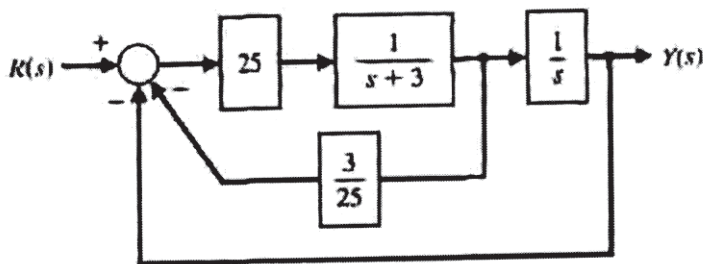

- Q7)** a) Explain Poles and Zeros of a First-Order System with example. [5]
 b) Explain design via State Space in detail. [5]
- Q8)** a) Draw a block diagram for a control system made up of the plant, the observer and the compensator. [5]
 b) What is the Block Diagram Representation in control system? [5]



Total No. of Questions : 8]

SEAT No. :

PA-3184

[Total No. of Pages : 2

[5928]-28

M.E. (Civil - Hydraulics)

FLUID MECHANICS

(2017 Pattern) (Semester - I) (501041)

Time : 3 Hours]

[Max. Marks : 50

Instructions to the candidates:

- 1) Answer Q.1 or Q.2, Q.3 or Q.4, Q.5 or Q.6, Q.7 or Q.8.
- 2) Figures to the right indicate full marks.
- 3) Assume suitable data, if necessary.
- 4) Use of non-programmable calculator is allowed.

- Q1)** a) Obtain an expression for continuity equation for a three-dimensional flow. [5]
b) The velocity components in a two dimensional flow are $u = y\frac{3}{3} + 2x - x^2y$ and $v = xy^2 - 2y - x\frac{3}{3}$. Show that these components represent a possible case of an irrotational flow. [4]

OR

- Q2)** a) Explain doublet and define the strength of doublet. [5]
b) The stream function for a two dimensional flow is given by $\psi = 8xy$, calculate the velocity at the point $p(4,5)$. [4]

- Q3)** a) A pipe of diameter 20 cm and length 10,000 m. is laid at a slope of 1 in 200. An oil of sp. gravity 0.9 and viscosity 1.5 poise is pumped at the rate of 20 lits/s. Find the head lost due to friction. [5]
b) Derive an expression for velocity distribution for viscous flow through a circular pipe. [4]

OR

- Q4)** a) Define displacement thickness. Derive an expression for the displacement thickness. [5]
b) Water is flowing over a thin smooth plate of length 4 m and width 2 m at a velocity of 1 m/s. If the boundary layer flow changes from laminar to turbulent at $R_e = 5 \times 10^5$, find the drag force due to laminar boundary layer. [4]

P.T.O.

- Q5) a)** What do you mean by Prandtl mixing length theory. Find the expression for shear stress due to Prandtl. [8]
- b) For turbulent flow in a pipe of diameter 300 mm, shear velocity $u_x = 0.1458$ m/s and Average velocity $\bar{U} = 1.4533$ m/s. Find the coefficient of friction and average height of roughness projections. [8]

OR

- Q6) a)** A smooth pipe of diameter 400 mm and length 800 m carries water at the rate of $0.04 \text{ m}^3/\text{s}$. Determine the head lost due to friction, wall shear stress, centre line velocity and thickness of laminar sub layer. [12]
- b) How would you distinguish between hydro-dynamically smooth and rough boundaries. [4]
- Q7) a)** Derive the continuity equation for one dimensional compressible flow in differential form. [8]
- b) i) Find the sonic velocity for the crude oil of sp. gr. 0.8 and bulk modulus 153036 N/cm^2 . [4]
- ii) Calculate the Mods number at a point on a jet propelled aircraft, which is flying at 1100 km/hr . at sea level where air temperature is 20°C . Take $K = 1.4$ and $R = 287 \text{ J/kg}^\circ\text{K}$. [4]

OR

- Q8) a) i)** Define Mach number. What is significance of Mach number in compressible fluid flows. [4]
- ii) Define the terms : Subsonic flow, Super-Sonic flow, Sonic flow and Mach angle. [4]
- b) An aeroplane is flying at an height of 15 km where the temperature is -50°C . The speed of the plane is corresponding to $M = 2.0$. Assuming $K = 1.4$ and $R = 287 \text{ J/kg}^\circ\text{K}$. Find the speed of the plane. [8]



Total No. of Questions : 7]

SEAT No. :

PA-777

[Total No. of Pages : 2

[5928]-280
M.E. (Mechanical-Mechatronics)
SENSORS, TRANSDUCERS AND INTERFACING
TECHNIQUES
(2017 Pattern) (Semester - I) (502803)

Time : 3 Hours]

[Max. Marks : 50

Instructions to the candidates:

- 1) *Attempt any five questions.*
- 2) *Figures to the right indicate full marks.*
- 3) *Draw neat figures, diagrams wherever necessary.*
- 4) *Use of non-programmable scientific calculator is allowed.*
- 5) *Assume suitable data, if necessary.*

Q1) a) Explain - [5]

- i) Chauvenet's criterion.
- ii) The chi-square test of goodness of fit.

b) Discuss the responsibilities of experimenter/observer while measuring the parameters. Also discuss the general considerations in data analysis. [5]

Q2) a) State the different techniques of frequency measurement & explain any one in detail. [5]

b) Draw a neat diagram of capacitive transducer & explain its working. State its applications. [5]

Q3) a) Explain working of - [5]

- i) Bridgman gauge
- ii) Pirani gauge

b) With suitable schematic explain the operation of Knudsen gauge. [5]

P.T.O.

- Q4)** a) With the help of neat diagram explain the working of magnetic flow meter. [5]
b) Write short notes on :- [5]
i) LDA
ii) Pressure probes
- Q5)** Explain the measurement schemes of following parameter with neat diagram, applications, advantages and drawbacks.(Any two) [10]
a) Viscosity measurement.
b) Thermal conductivity measurement
c) Humidity measurement
- Q6)** a) Explain the basic principle of electrical resistance strain gauge. State the different applications & explain any one application in brief. [5]
b) With neat diagram explain Rosette strain gauge. [5]
- Q7)** a) State the important specifications of Digital-to-Analog converter. With the help of neat circuit diagram explain the circuit of inverted R-2R ladder n/w DAC. [5]
b) State the various displays used in DAS & explain working of any one display. [5]



Total No. of Questions : 8]

SEAT No. :

PA-778

[Total No. of Pages : 3

[5928]-281

M.E. (Mechanical-Mechatronics)
PLC PROGRAMMING
(2017 Pattern) (Semester - II) (502807)

Time : 3 Hours]

[Max. Marks : 50

Instructions to the candidates:

- 1) *Attempt any five questions.*
- 2) *Neat diagrams must be drawn wherever necessary.*
- 3) *Figures to the right side indicate full marks.*
- 4) *Use of calculator is allowed.*
- 5) *Assume suitable data if necessary.*

Q1) A pump is to be used to fill two storage tanks. The pump is manually started by the operator from a START/STOP station. When the first tank is full, the control logic must be able to automatically stop flow to the first tank and direct flow to the second tank through the use of sensors and electric solenoid valves. When the second tank is full, the pump must shut down automatically. Indicator lamps are to be included to signal when each tank is full. **[10]**

- a) Draw a sketch of the process.
- b) Prepare a typical PLC program for this control process.

Q2) a) What type of output devices can be controlled by an output module that uses relays for the switching device. **[4]**

- b) State three other functions, in addition to simple logic processing, that PLC processors are capable of performing. **[6]**

Q3) a) When is the output of a programmed timer energized? **[4]**

- b) Explain the difference between the timed and instantaneous contacts of a pneumatic timer. **[6]**

P.T.O.

Q4) a) Convert each of the following binary numbers to decimal numbers : **[4]**

- i) 10
- ii) 100
- iii) 111
- iv) 1011

b) Draw the logic symbol. Construct a truth table, and state the Boolean equation for each of the following : **[6]**

- i) Two-input AND gate
- ii) Three-input OR gate
- iii) NOT function

Q5) a) When the lights are turned off in a building, an exit door light is to remain on for an additional 2 min, and the parking lot lights are to remain on for an additional 3 min after the door light goes out. Write a PLC program to implement this process. **[6]**

b) What is the main advantage of the jump instruction? **[4]**

Q6) Draw the electrical symbol used to represent each of the following PLC output control devices : **[10]**

- a) Pilot light
- b) Relay
- c) Motor starter coil
- d) OL relay contact
- e) Alarm
- f) Heater
- g) Solenoid
- h) Solenoid valve
- i) Motor
- j) Horn

- Q7)** a) State advantages of using programmed PLC timers. [4]
- b) Explain what each of the following quantities associated with a PLC timer instruction represents : [6]
- i) Preset time
 - ii) Accumulated time
- Q8)** a) Name the forms of PLC counter instructions. And explain the basic operation of each. [4]
- b) Write a program that will latch on a light 20s after an input switch has been turned on. The timer will continue to cycle up to 20s and reset itself until the input switch has been turned off. After the third time the timer has timed to 20s, the light will be unlatched. [6]



[5928]- 282

M.E. (Mechanical -Mechatronics)
CONTROL SYSTEMS- II
(2017 Pattern) (Semester - II) (502808)

Time : 3 Hours]

[Max. Marks : 50

Instructions to the candidates:

- 1) Answer any five questions.
- 2) Neat diagrams must be drawn wherever necessary.
- 3) Figures to the right side indicate full marks.
- 4) Use of Calculator is allowed.
- 5) Assume suitable data if necessary.

Q1) In comparison to time domain analysis, discuss the advantages and the dis-advantages of the frequency domain analysis. [10]

Q2) a) From the bode blot in Figure 1 determine the approximate value of the gain margin as well as the phase margin and comment on the closed loop stability of the system. [6]

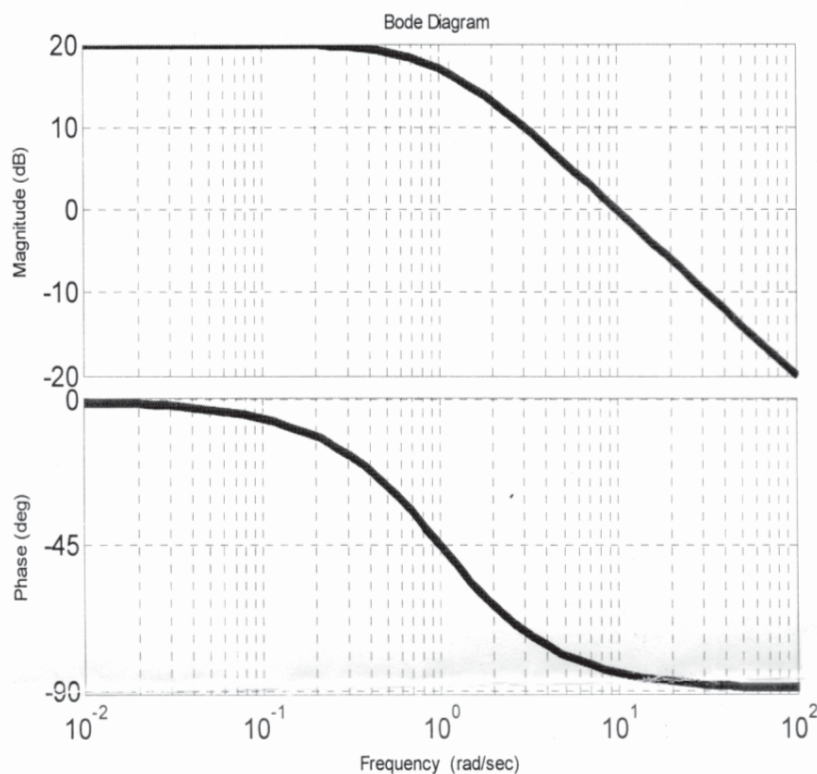

Figure 1

b) Define the Nyquist stability criterion and discuss the effect of time delay on closed loop stability of a system. [4]

P.T.O.

Q3) Derive the transfer function of the PID controller. Also, discuss the significance the P, I and D element of the controller. **[10]**

Q4) Using the ZN step response method determine the gains as well as the equation for the control signal of the PID control in series form. Assume $a = 0.218$ and $L = 0.806$. **[10]**

Q5) Draw a suitable diagram and discuss a technique to overcome the effect of “Actuator Windup”. **[10]**

Q6) Write down the equation and discuss the relationship between Sensitivity and Gain Margin. **[10]**

Q7) a) Draw a suitable block diagram and discuss the design of the ITAE system. **[6]**

b) Draw a suitable diagram and explain the working of the IMC controller. **[4]**



Total No. of Questions : 8]

SEAT No. :

PA-780

[Total No. of Pages : 2

[5928]-283

M.E. (Mechanical) (Mechatronics)
INDUSTRIAL DRIVES AND ACTUATORS
(2017 Pattern) (Semester - II) (502809)

Time : 3 Hours]

[Max. Marks : 50

Instructions to the candidates:

- 1) *Attempt any five questions.*
- 2) *Neat diagrams must be drawn wherever necessary.*
- 3) *Figures to the right side indicate full marks.*
- 4) *Use of calculator is allowed.*
- 5) *Assume suitable data if necessary.*

Q1) Describe : **[10]**

- a) Group Drive
- b) Individual Drive and
- c) Multi-motor drive in detail

Q2) a) Describe dynamics of motor and load mathematically. **[5]**

b) Explain construction and working principle of DC motor. **[5]**

Q3) Explain four quadrant operation of DC motor Drive. **[10]**

Q4) a) Explain Speed control of Induction motor by static slip power recovery scheme. **[5]**

b) Derive torque angle relationship for synchronous motor drive. **[5]**

Q5) Enlist the advantages, limitations and applications of Hydraulic Systems and Electric Systems. **[10]**

P.T.O.

- Q6)** a) Draw hydraulic circuit symbols used to represent Unloading valve and pressure compensated flow valve with working. [5]
- b) Explain the application of sequence valve and pressure relief valve in industrial hydraulic circuits. [5]
- Q7)** a) Draw hydraulic circuit symbols used to represent sequence valve and pressure compensated pressure relief valve with working. [5]
- b) Discuss meter in circuit in Pneumatic systems and identify how it differs in working as compared to hydraulic meter in circuit. [5]
- Q8)** Answer any two : [10]
- a) Give the comparison between AC and DC drives
- b) Explain reduced voltage starting of Induction motor
- c) Write a short note on Unloading Valve
- d) Short note on Encoders w.r.t. actuators



Total No. of Questions : 8]

SEAT No. :

PA-781

[Total No. of Pages : 2

[5928]-284

M.E (Mechanical Engg.) (Mechatronics)

MICROCONTROLLER APPLICATIONS IN EMBEDDED SYSTEMS

(2017 Pattern) (Semester - III) (602813)

Time : 3 Hours]

[Max. Marks : 50

Instructions to the candidates:

- 1) *Answer any five questions.*
- 2) *Neat diagrams must be drawn whenever necessary.*
- 3) *Figures to the right indicate full marks.*
- 4) *Assume suitable data, whenever necessary.*

Q1) a) Explain with neat diagram programming model of PIC18F microcontroller. **[5]**

b) List and explain the instructions used for arithmetic operations of PIC microcontroller. **[5]**

Q2) a) Draw and explain data memory of PIC18F microcontroller. **[5]**

b) With neat diagram explain support devices of PIC18F microcontroller. **[5]**

Q3) a) What are different types of conditional and unconditional branch instructions? **[6]**

b) Explain the result after the execution of the following instructions. Identify the status of flags. **[4]**

MOVLW FAH

ADDLW 38H

P.T.O.

- Q4)** a) What is subroutine? Explain PIC18 CALL and RETURN Instructions. [5]
b) With neat circuit diagram, explain interfacing of LCD to PIC microcontroller. [5]
- Q5)** a) With neat circuit diagram, how push buttons are interfaced to PIC microcontroller? [5]
b) What are Interrupts? Explain different types of interrupts. [5]
- Q6)** a) What is function of different timers used in PIC18F microcontroller. [5]
b) Why Analog to Digital conversion is required? Explain any one method in detail. [5]
- Q7)** a) Explain basic concepts in serial communication. [5]
b) Explain with block diagram Inter-Integrated circuit protocol. [5]
- Q8)** a) Discuss the hardware aspect of Embedded system design by considering Time and Temperature monitoring System (TTMS) as a case study. [6]
b) Explain the features of embedded systems. [4]



Total No. of Questions : 8]

SEAT No. :

PA-2678

[Total No. of Pages : 2

[5928]-285

M.E. (Mechanical-Mechatronics)
FLEXIBLE MANUFACTURING SYSTEMS
(2017 Pattern) (Semester - III) (602814)

Time : 3 Hours]

[Max. Marks : 50

Instructions to the candidates:

- 1) *Answer any five questions.*
- 2) *Neat diagrams must be drawn wherever necessary.*
- 3) *Figures to the right indicate full marks.*
- 4) *Use of calculator is allowed.*
- 5) *Assume suitable data, if necessary.*

Q1) What is CAPP? Explain the any one type of CAPP with neat sketches. [10]

Q2) a) What are the four factor that favour the use of manual assembly line.[4]

b) What are the three problem areas that must be considered in the analysis and design of an automated production line? [6]

Q3) a) Describe the various workstations of FMS. [4]

b) Write a short note on Group Technology. [6]

Q4) a) Explain the working of NC machine tool with the help of the diagram.[4]

b) Describe, with neat sketch, ASRS system used in FMS. [6]

Q5) a) Explain in brief about DNC. [4]

b) List out and Explain about basic components of an NC system and CNC system. [6]

Q6) a) What is machine vision system and how it works? [4]

P.T.O.

- b) Mobile charger supplier drawn randomly constant sample size of 500 chargers every day for quality control test. Defects in each charger are recorded during testing & tabulated as follows. [6]

Lot No.	Sample Size	Number of defects in sample[c]
1	500	12
2	500	14
3	500	16
4	500	18
5	500	16
6	500	14
7	500	12
8	500	12
9	500	32
10	500	16
11	500	18
12	500	16
13	500	14
14	500	12
15	500	16
16	500	18
17	500	12
18	500	19
19	500	18
20	500	21

Draw the appropriate control chart and comment on the state of control.

- Q7) a)** Write Short note on-Concept of six sigma. [4]

- b) What are the components on which success of Concurrent Engineering depend? [6]

- Q8) a)** Differentiate MRP-I and MRP-II. [4]

- b) Explain how DFM helps in reducing the manufacturing cost of a product? [6]



Total No. of Questions : 3]

SEAT No. :

PA-782

[Total No. of Pages : 1

[5928]-290
M.E. (Printing)
COLOUR SCIENCE
(2017 Pattern) (Semester - II) (508107)

Time : 3 Hours]

[Max. Marks : 50

Instructions to the candidates:

- 1) Neat diagrams must be drawn wherever necessary.*
- 2) Assume suitable data wherever necessary.*
- 3) Figures on right indicate marks.*
- 4) All questions are compulsory.*

Q1) Explain following terms : **[18]**

- a) Simultaneous contrast
- b) Image formation by eye
- c) Chromatic aberration of eye

Q2) Write short notes on : **[16]**

- a) Perceptibility Vs Acceptability
- b) Instrumental assessment method

Q3) What is metamerism? **[16]**

What are its causes? What is degree of metamerism, explain metamerism index also.



Total No. of Questions : 6]

SEAT No. :

PA-783

[5928]- 291

[Total No. of Pages : 2

M.E. (Printing Engg. & Graphic Communication)

WEB HANDLING ON PRESS

(2017 Pattern) (Semester - II) (508108)

Time : 3 Hours]

[Max. Marks : 50

Instructions to the candidates:

- 1) *All questions are compulsory.*
- 2) *Neat diagrams must be drawn wherever necessary.*
- 3) *Assume suitable data if necessary.*

Q1) a) State the working of zero speed slicing. What are the advantages of this splicer. **[9]**

b) What is the significance of corona treatment? Explain any one methodology of treatment done for plastic films. **[9]**

OR

Q2) a) Write short notes on: **[18]**

- i) Factors influencing tension in printing unit of gravure press.
- ii) Factors influencing tension in gravure print unit.

Q3) a) Explain procedure to check and control registration during printing in a web offset press. **[8]**

b) Where is the position of compensator roller? State the significance of the compensator roller for registration purpose in a web offset press. **[8]**

OR

Q4) What is the purpose of web guide rollers in a offset press? How do metal surface rollers and rubber surface rollers differ in web tensions? **[16]**

P.T.O.

Q5) What is Static and Dynamic balancing. How is it measured and calculated?
Why does balance of rollers change in printing machine. **[16]**

OR

Q6) State the surface structures of rollers used as web transport rollers. **[16]**

What are angle bars. Write a note on different angle bars and their benefits on the web machine.



Total No. of Questions : 6]

SEAT No. :

PA-784

[Total No. of Pages : 2

[5928]-292

M.E (Printing Engineering and Graphic Communication)

SUBSTRATE AND INK

(2017 Pattern) (Semester - II) (508109)

Time : 3 Hours]

[Max. Marks : 50

Instructions to the candidates:

- 1) *Solve Questions Q1 or Q2, Q3 or Q4 and Q5 or Q6.*
- 2) *Neat diagrams to be drawn wherever necessary.*
- 3) *Assume suitable data wherever necessary.*
- 4) *Figures to the right indicate marks.*

- Q1)** a) Explain difference in chemical and mechanical pulping. [6]
- b) Discuss any two surface properties of paper and testing methods. [6]
- c) Give typical formulation of water-based gravure ink. [6]

OR

- Q2)** a) State and explain importance of refining stage in paper manufacturing. [6]
- b) Discuss any two optical properties of paper and testing methods. [6]
- c) Give typical formulation of sheet fed lithographic ink. [6]

- Q3)** Calculate paper required for printing 1000 copies of 8 "X 11" size 4-page brochure in 4+4 color. [16]

OR

- Q4)** Calculate paper required for printing 5000 copies of 8 "X 11" size 2-page leaflet in 2+2 color. [16]

P.T.O.

Q5) Comment on following : **[16]**

- a) VOC and its significance in printing inks
- b) Quality control for substrate and ink

OR

Q6) Comment on following : **[16]**

- a) QC for paste Ink
- b) Hazardous waste in printing.



Total No. of Questions : 3]

SEAT No. :

PA-785

[Total No. of Pages : 1

[5928]-293

M.E (Printing Engineering and Graphic Communication)

PRINTED ELECTRONICS & RFID

(2017 Pattern) (Semester - III) (608101)

Time : 3 Hours]

[Max. Marks : 50

Instructions to the candidates:

- 1) Neat diagrams must be drawn wherever necessary.*
- 2) Assume suitable data wherever necessary.*
- 3) Figures to the right indicate full marks.*

Q1) a) What is Printed electronics and Discuss its scope? [6]

b) Explain different functional layers used in electronics manufacturing. [6]

c) What are the traditional methods for electronics manufacturing? Explain one of them in detail. [6]

Q2) Explain in detail RFID working. Why RFID will replace barcodes in supply chain? [16]

Q3) Discuss use of printed electronics in Healthcare Management. [16]



Total No. of Questions : 3]

SEAT No. :

PA-2614

[Total No. of Pages : 1

[5928]-294

M.E. (Printing Engineering & Graphic Communication)

ADVANCES IN CONVERTING AND PACKAGING

(2017 Pattern) (608102) (Semester - III)

Time : 3 Hours]

[Max. Marks : 50

Instructions to the candidates:

- 1) *Draw neat diagram wherever necessary.*
- 2) *Figures to the right indicates full marks.*

Q1) Explain the converting techniques used for publication. [18]

OR

Explain in detail Lamination techniques used in packaging. [18]

OR

Explain in detail Solvent-less Lamination process. [18]

OR

Explain in detail pouch-making process. [18]

Q2) Explain in detail Co-extrusion process. [16]

OR

Explain the role of PE in packaging. [16]

Q3) Explain in detail barrier applications to the package for a product. [16]

OR

Explain in detail aseptic packaging. [16]



Total No. of Questions : 8]

SEAT No. :

PA-786

[Total No. of Pages : 2

[5928] - 296

M.E. (Production) (Manufacturing and Automation Engineering)

RESEARCH METHODOLOGY

(2017 Pattern) (511102) (Semester-I)

Time : 3 Hours]

[Max. Marks : 50

Instructions to the candidates :

- 1) *Solve Q.1 or Q.2, Q.3 or Q.4, Q.5 or Q.6, Q.7 or Q.8.*
- 2) *Figures to the right indicate full marks.*
- 3) *Neat diagrams must be drawn wherever necessary.*
- 4) *Assume suitable data if necessary.*
- 5) *Use of Logarithmic Table, Slide rule is Electronic pocket calculator is allowed.*

Q1) a) Elaborate various objectives for doing research. [4]

b) Explain the descriptive research method. Elaborate how it is beneficial. [5]

OR

Q2) a) Explain the importance of doing research. How research is beneficial to the society. [4]

b) Compare types of research approaches. [5]

Q3) a) Elaborate study of research design is essential. Explain it. [4]

b) Discuss different methods of research design. [5]

OR

Q4) a) Elaborate basic principle of research design. [4]

b) Describe various methods of Design of Experiment. [5]

P.T.O.

- Q5)** a) Elaborate various types of data collection methods in [8]
b) Explain content analysis in detail. [8]

OR

- Q6)** a) Brief on devices used in data collection. Explain any two devices. [8]
b) Why Pilot Study is important? Describe it with any case study. [8]

- Q7)** a) Describe Analytical Hierarchy Process in detail. [8]
b) What is graph theory? How its study is significant? [8]

OR

Q8) Write a short notes on (Any 2) : [16]

- a) TOPSIS.
- b) Significance of report writing.
- c) Various layouts of research report.
- d) Techniques of interpretation in research.



Total No. of Questions : 8]

SEAT No. :

PA-787

[Total No. of Pages : 2

[5928] - 297

M.E. (Production) (CAD/CAM)
COMPUTERAIDED DESIGN
(2017 Pattern) (Semester - I) (511301)

Time : 3 Hours]

[Max. Marks : 50

Instructions to the candidates :

- 1) *Attempt Q.1 or Q.2, Q.3 or Q.4 and Q.5 or Q.6.*
- 2) *Q.7 and Q.8 are compulsory.*
- 3) *Figures to the right indicate full marks.*
- 4) *Draw neat self-explanatory sketches wherever necessary.*
- 5) *Use of calculator is allowed.*
- 6) *Assume suitable data, if necessary.*

Q1) Discuss applications of computers for design. **[5]**

OR

Q2) Discuss Grover's Model of Product Life Cycle for Selection of CAD/CAM. **[5]**

Q3) Why parametric representation of geometrical entities are preferred in CAD software? Explain your answer with non-parametric and parametric equations of appropriate geometric entity. **[5]**

OR

Q4) What is Homogeneous Co-ordinate system? Explain the necessity of Homogeneous co-ordinate system for transformation of geometric entities using suitable examples. **[5]**

Q5) What is blending of curves? Explain how two Bezier segments can be blended with suitable numeric example. **[7]**

OR

P.T.O.

Q6) Explain the procedure of mass property calculations in CAD software. **[7]**

Q7) a) What sweep representation scheme used for representation of a solid. **[8]**

b) What is Z-buffer algorithm for B-REP and CSG model? **[7]**

Q8) Write short note on any three : **[18]**

a) Shading algorithms.

b) Virtual Realism.

c) Parametric programming.

d) Feature based segmentation.



Total No. of Questions : 6]

SEAT No. :

PA-788

[Total No. of Pages : 2

[5928]-298

M.E. (Production) (CAD/CAM)
COMPUTER AIDED MANUFACTURING
(2017 Pattern) (Semester - I) (511302)

Time : 3 Hours]

[Max. Marks : 50

Instructions to the candidates :

- 1) Answer Q1 or Q2, Q3 or Q4 and Q5 & Q6 are compulsory.
- 2) Assume suitable data if necessary.
- 3) Figures to the right indicate full marks.
- 4) Neat diagrams must be drawn wherever necessary.

Q1) a) Explain Direct Numeric Control (DNC) system. [5]

b) Explain principle of rolling guide ways in CNC machines. [5]

OR

Q2) Write NC program for the following job and also explain the meaning of each step (block). [10]



Q3) a) Explain CNC-EDM in detail. [5]

b) Explain working principle of automatic welding machine with block diagram. [5]

OR

P.T.O.

- Q4)** a) Explain various types of conveyors used in automated material handling system. [5]
- b) Explain Automated Guided Vehicle (AGV) system. [5]
- Q5)** a) Write short note on machine vision. [7]
- b) Explain optical inspection methods. [8]
- Q6)** a) Explain use of bar code system for shop floor data collection? [8]
- b) Comment on: future automated factory and unemployment. [7]



Total No. of Questions : 8]

SEAT No. :

PA-789

[Total No. of Pages : 2

[5928]-299

M.E Production (CAD/CAM)/(Manufacturing and Automation)

COMPUTER INTEGRATED MANUFACTURING

(2017 Pattern) (Semester - II) (511305)

Time : 3 Hours]

[Max. Marks : 50

Instructions to the candidates:

- 1) *Attempt Q1 or Q2, Q3 or Q4 and Q5 or Q6.*
- 2) *Q7 and Q8 are compulsory.*
- 3) *Figures to the right indicate full marks.*
- 4) *Draw neat self – explanatory sketches wherever necessary.*
- 5) *Use of calculator is allowed.*
- 6) *Assume suitable data, if necessary.*

Q1) What are the benefits of GT to the manufacturing industry? **[5]**

OR

Q2) Which approaches are considered in order to optimize overall efficiency and effectiveness of FMS? **[5]**

Q3) What is a relational database? Describe the architecture of database management system. **[5]**

OR

Q4) What are the different levels of Integration against evolution of CIM? Explain. **[5]**

Q5) What are the components of PLM software? Explain. **[7]**

OR

Q6) Which are the typical sensors that are normally used in robot? Explain. **[7]**

P.T.O.

Q7) a) What are the components of small local area network in CIM setup? Explain. [8]

b) What are the communication interfaces used in computer-to-computer communication? Explain in brief. What are the commonly used interface cards? [7]

Q8) Write short notes on any three : [18]

a) AGV

b) Data associated with FMC

c) ESPRIT – CIM OSA model

d) GKS implementation in a CAD workstation



Total No. of Questions : 10]

SEAT No. :

PA-580

[Total No. of Pages : 2

[5928]-3

M.E. (Civil) (Construction & Management)

CONSTRUCTION TECHNOLOGY

(2017 Course) (Semester - I) (501023)

Time : 3 Hours]

[Max. Marks : 50

Instructions to the candidates:

- 1) *Attempt Q.1 or Q.2, Q.3 or Q.4, Q.5 or Q.6 and Q.7 or Q.8 and Q.9 or Q.10.*
- 2) *Neat diagrams must be drawn wherever necessary.*
- 3) *Figures to the right indicate full marks.*
- 4) *Assume suitable data, if necessary and clearly state.*
- 5) *Use of cell phone is prohibited in the examination hall.*
- 6) *Use of electronic pocket calculator is allowed.*

Q1) a) Define vibro-compaction method of soil compaction and Explain any one in detail. **[5]**

b) State objectives of the dewatering system. Explain Electroosmosis dewatering method. **[5]**

OR

Q2) a) Explain Electro Osmosis dewatering process in detail with its applicability. **[5]**

b) Enlist the grouting materials used. Focus on cement grouting in detail. **[5]**

Q3) a) Explain Boom Placer? State its necessity and draw well sketch which is showing angles of its. **[5]**

b) Explain the sequential operations involved in construction of sheet pile cofferdam for construction of bridge pier. **[5]**

OR

Q4) a) Explain in detail Jet grouting and Chemical grouting. **[5]**

b) “Rapid Hardening Cement is suitable for under water concreting”, support this statement with conditions of underwater and characteristics of RHC. **[5]**

P.T.O.

- Q5) a)** Discuss the operations involved in construction of diaphragm wall. [5]
b) Explain Cofferdam wall by ICOS method in detail. [5]

OR

- Q6) a)** Explain construction of double wall cofferdam. [5]
b) Which factors are considered in geotechnical investigation of caisson construction? State importance of each factor. [5]

- Q7) a)** Explain components of coffer dam with diagram. [5]
b) Explain in detail bored - Piles. [5]

OR

- Q8) a)** Explain the methods of support during pile driving with diagram. [5]
b) Explain with neat diagrams about pile capacity. [5]

- Q9) a)** Explain in detail precast caissons and write its advantages and disadvantages. [5]
b) Discuss methods of construction for well foundations. [5]

OR

- Q10) a)** Explain with neat sketch earth and rock fill cofferdam with its advantages and disadvantages. [5]
b) Explain pneumatic caissons in details. [5]



Total No. of Questions : 8]

SEAT No. :

PA-790

[5928]- 300

[Total No. of Pages : 3

**M.E. (Production(CAD/CAM)/Manufacturing & Automation)
ARTIFICIAL INTELLIGENCE AND ROBOTICS (2017
Pattern) (Semester - II) (511306)**

Time : 3 Hours]

[Max. Marks : 50

Instructions to the candidates:

- 1) *Answer any five questions.*
- 2) *Neat diagrams must be drawn wherever necessary.*
- 3) *Figures to the right indicate full marks.*
- 4) *Use of calculator is allowed.*
- 5) *Assume suitable data if necessary.*

Q1) a) State in brief the following terms. **[4]**

- i) Degree of freedom of a spatial and planar manipulator
- ii) Major and Minor axis of robot arm

b) Justify the following statements **[4]**

- i) Dexterous workspace is subset of reachable workspace
- ii) CNC machine is not a robot

c) Sketch cylindrical arm configuration **[2]**

Q2) a) Discuss rules for D-H algorithm for the assignment of link coordinates system. **[5]**

b) State the characteristics of Robot. **[5]**

The mechanism connecting wrist assembly is a twisting joint which can be rotated through 6 full rotations from start to end position. It is desired to have control resolution of rotation of ± 0.35 . What is the number of bit storage capacity to achieve this resolution?

P.T.O.

- Q3) a)** Consider the forward transformation of the two-joint manipulator shown in fig. Given that the length of joint 1, $L_1 = 100\text{mm}$, the length of joint 2, $L_2 = 100\text{mm}$, the angle $\theta_1 = 45^\circ$, and the angle $\theta_2 = 60^\circ$, compute the coordinate position for the end - of - the - arm P_x [6]

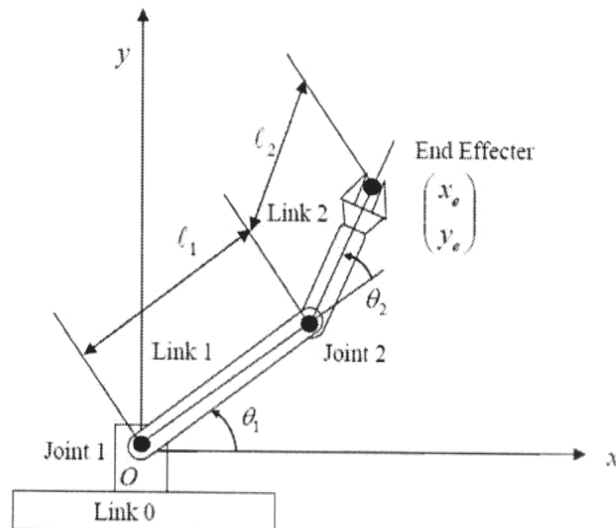

- b) Write note on drives used in robot control [4]

- Q4) a)** Explain the principle of vacuum type gripper with neat sketch. [4]

- b) State various factors for the selection of gripper. [6]

A part weighing 150N is to be grasped by a mechanical gripper using friction between two opposing fingers. The coefficient of friction is 0.35 . The orientation of the gripper will be such that the weight of the part will be applied in a direction parallel to the contacting finger surfaces. Take g factor in force calculations equal to 3.0 . Compute the required gripper force for the above specification.

- Q5) a)** Describe the architecture of PID control. [4]

- b) Explain following : MOVE, WAIT, SIGNAL, DELAY with an pick and place example. [6]

- Q6)** a) Briefly describe image reduction techniques in machine vision system. [5]
b) Write a short note on Tactile sensors. [3]
c) How digital image is represented for robotic vision? [2]
- Q7)** a) Explain the singularity of a manipulator? [4]
b) Explain the methods of problem solving in A.I. [6]
- Q8)** a) Discuss [5]
i) Characteristics of sensors
ii) Remote sensor compliance
- b) Define “Artificial Intelligence” Speculate role of AI techniques in application of Industrial robots. [5]



Total No. of Questions : 06]

SEAT No. :

PA-791

[Total No. of Pages : 2

[5928]-301

M.E. (Production) (CAD/CAM)

COMPUTATION TECHNIQUES IN CAD/CAM

(2017 Pattern) (Semester - II) (511307)

Time : 3 Hours]

[Max. Marks : 50

Instructions to the candidates:

- 1) Attempt Q1 or Q2, Q3 or Q4, and Q5 or Q.6 are compulsory.
- 2) Assume suitable data if necessary.
- 3) Figures to the right side indicate full marks.
- 4) Neat diagrams must be drawn wherever necessary.

Q1) Write a short note on (any two)

[10]

- a) FEA tool for design.
- b) FEA element types and characteristics.
- c) Co-ordinate system in FEA

OR

Q2) a) Explain in short photoelastic method of stress analysis.

[5]

b) What are classification of fatigue testing machines and explain any one?

[5]

Q3) a) Explain in short numerical method for convection.

[5]

b) What is discretization? Any one method of numerical discretization.

[5]

OR

Q4) a) Solve the following equation?

[5]

$$\frac{dy}{dx} = x - 2y$$

Using Range-Kutta 4th order method.

Given: y = 1 when x = 0 and

Find y at x= 0.1 taking h = 0.1

P.T.O.

b) Solve the system of equations using Gauss-Seidel iteration method. [5]

$$28x_1 + 4x_2 - x_3 = 32$$

$$x_1 + 3x_2 - 10x_3 = 24$$

$$2x_1 + 17x_2 - 4x_3 = 35$$

Q5) Write short note on (any three) [15]

- a) Integer programming
- b) Gradient base method
- c) Direct search methods
- d) Point elimination methods

Q6) a) Write steps in conducting steepest descent method used for global optimization. [7]

b) What is a function value corresponding to coded substring value 1101 in Genetic Algorithm (GA) to minimize the function [8]

$$f(x) = x_1^2 + 3x_2 + 10$$

With in

$$0 \leq x_1, x_2 \leq 3$$



Total No. of Questions : 8]

SEAT No. :

PA-2616

[Total No. of Pages : 2

[5928] - 302

**M.E. (Production - Manufacturing & Automation)/(CAD/CAM)
COMPUTATIONAL INTELLIGENCE IN TOOL DESIGN
(2017 Pattern) (Semester - III) (611101)**

Time : 3 Hours]

[Max. Marks : 50

Instructions to the candidates :

- 1) *Answer any five questions.*
- 2) *Neat diagrams must be drawn wherever necessary.*
- 3) *Figures to the right side indicate full marks.*
- 4) *Use of calculator is allowed.*
- 5) *Assume suitable data, if necessary.*

Q1) What do you mean by fixture constraint analysis? Discuss applications of AI techniques for this analysis. **[10]**

Q2) The spring back (S) in bending operations depends on sheet thickness (t , mm), sheet orientation (θ , degrees) and punch tip radius (r , mm) and their relationship can be mathematically expressed as : **[10]**

$$S = -24.7 + 13.3t + 9.19r - 4.06t.r + 0.0073r.\theta + 0.941t^2 - 0.607r^2 .$$

Perform two iterations of simulated annealing algorithm to minimize S considering bounds of variables as :

$$0.5 \leq t \leq 1 \text{ mm,}$$

$$0 \leq \theta \leq 90 \text{ degrees}$$

$$2 \leq r \leq 5 \text{ mm}$$

Q3) Explain role of AI techniques for determination of parting line in forging operation. **[10]**

P.T.O.

Q4) Write short notes on : **[10]**

- a) Prediction of life of compound die.
- b) Automated Blank nesting in press tools.

Q5) Explain following algorithms commonly used in intelligent manufacturing systems **[10]**

- a) Random forest.
- b) Naive Bayes.
- c) K-Nearest Neighbors.
- d) Adaptive boosting.

Q6) Explain the factors to be considered while determining optimum number of cavities in die casting. How the optimum number of cavities can be calculated? **[10]**

Q7) Following experiments were conducted to analyze the effect of sand particle size (S), mold hardness (H) and permeability (P) on casting defects (D). Using multiple regression, derive an expression for casting defects in terms of S , H and P . **[10]**

Experiment Number	S (AFS)	H (nu)	P (nu)	D (%)
1	50	50	150	5.25
2	55	50	150	4.48
3	50	80	150	6.47
4	55	80	150	3.93
5	50	50	220	7.29
6	55	50	220	2.64
7	50	80	220	3.75
8	55	80	220	6.34

Q8) Write short notes : **[10]**

- a) Optimal design of feeding system in die casting.
- b) Cavity balancing in injection molding.



Total No. of Questions : 6]

SEAT No. :

PA-792

[Total No. of Pages : 2

[5928]-303

M.E. (Production) (CAD/CAM)
(511311) COMPUTER AIDED PROCESS PLANNING
(2017 Pattern) (Semester - III)

Time : 3 Hours]

[Max. Marks : 50

Instructions to the candidates :

- 1) *Q.No. 5 and Q.No. 6 are compulsory.*
- 2) *Answers to the two sections should be written in separate answer books.*
- 3) *Neat diagrams must be drawn wherever necessary.*
- 4) *Figures to the right indicate full marks.*
- 5) *Use of non-programmable calculator is allowed.*
- 6) *Assume suitable data, if necessary.*

- Q1)** a) Discuss demand patterns with suitable sketches. [5]
b) Discuss assignment model adding new machines to existing facility. [5]

OR

- Q2)** a) What are the algorithms used for group technology? Explain in detail. [5]
b) Discuss the benefits of group technology. [5]

- Q3)** a) Briefly describe various measures of performance in multiple machine scheduling problem with independent jobs. [4]

- b) What are the objectives of MRP? What is the input for MRP. [6]

OR

- Q4)** a) What is need for computer aided process planning? Describe the structure of process plan. [6]

- b) Describe types of simulations. [4]

P.T.O.

- Q5)** a) Four jobs are to be processed using three machines. The time required on machine 'j' for job 'i' is given in the table below. [8]

Job i	Time Required on machine		
	Machine A	Machine B	Machine C
1	6	9	20
2	7	27	5
3	30	4	6
4	2	7	3

How the jobs should be scheduled so as to minimize the total time required to complete all the jobs.

- b) Explain mathematical model for machine component cell formation. [7]

- Q6)** Write short notes on the following : [15]

- a) Measurement of forecast accuracy.
- b) GT.
- c) Manufacturing Execution System (MES).



Total No. of Questions : 8]

SEAT No. :

PA-793

[Total No. of Pages : 2

[5928]-304

M.E. (Production Engineering) (Manufacturing & Automation)

ADVANCED MANUFACTURING PROCESSES

(2017 Pattern)(Semester - I) (511103)

Time : 3 Hours]

[Max. Marks : 50

Instructions to the candidates :

- 1) *Attempt any five questions.*
- 2) *Neat diagrams must be drawn wherever necessary.*
- 3) *Figures to the right indicate full marks.*
- 4) *Assume suitable data, if necessary.*
- 5) *Use of electronic pocket calculator and logarithmic tables is allowed.*

- Q1)** a) Which are the important steps followed in the modern foundries during sand casting? [4]
- b) How mold filling and solidification simulation help to improve casting quality? [4]
- c) How conventional machining processes fail to fulfill demands of modern industries? [2]
- Q2)** a) Which are the non-conventional machining processes used for machining of advanced engineering materials? [4]
- b) Describe important characteristics EDMed parts. [4]
- c) List out important blow molding defects with their remedies. [2]
- Q3)** a) Explain with neat sketch working principle Abrasive water jet machining. [4]
- b) How to identify arc welding defects and remove them? [4]
- c) Differentiate between destructive and Non-destructive testing's. [2]

P.T.O.

- Q4)** a) Describe principle of material removal, advantages and limitations of ECM. [5]
b) Explain various arc welding defects with their causes and remedies. [5]
- Q5)** a) A wire of 15 mm diameter is to be reduced to 7.5 mm diameter. The die angle is 15° and the coefficient of friction at dies and wire interface is 0.5. The flow stress of wire material is 340 N/mm^2 . Determine drawing stress and drawing load if the drawing speed is 0.7 m/s. [4]
b) Explain metal high speed hot forging with neat sketch. [4]
c) List out various the non-conventional forming processes. [2]
- Q6)** a) Explain metal stretch forming with neat sketch. [4]
b) Explain high energy rate forming with neat sketch. [4]
c) Differentiate between hot forming and cold forming. [2]
- Q7)** a) Explain important process parameters of electro-hydraulic forming. [4]
b) A tube of 12 mm external diameter and 1mm thickness is to be reduced to 16 mm external diameter and 0.5 mm thickness. The die angle is 24° and plug angle is 16° . The coefficients of friction at die and tube interface and tube and plug (mandrel) interface is 0.5. The flow stress of tube material is 340 N/mm^2 . The tube drawing is carried at a speed of 0.4 m/s. Calculate the fixed plug. [4]
c) What is high speed blanking? [2]
- Q8)** a) Explain forming limit diagram. [5]
b) Explain various rolling problems. [5]



Total No. of Questions : 8]

SEAT No. :

PA-794

[Total No. of Pages : 2

[5928]-305

**M.E. (Production) (Manufacturing and Automation)
(CAD/CAM)**

INDUSTRIAL AUTOMATION

(2017 Pattern) (Semester - I) (511104)

Time : 2 Hours]

[Max. Marks : 50

Instructions to the candidates :

- 1) *Solve any five questions.*
- 2) *Figures to the right indicate full marks.*
- 3) *Neat diagrams must be drawn wherever necessary.*
- 4) *Assume suitable data, if necessary.*
- 5) *Use of Logarithmic Table, Slide rule, Electronic pocket calculator is allowed.*

Q1) a) For a swash plate type of pump following data operates:

Number of pistons = 6, Piston diameter = 25 mm, Pitch circle diameter of the cylinder = 180 mm. Input power = 8 kW, Volumetric efficiency = 90%, Mechanical efficiency = 89. Calculate theoretical pump displacement and angle of swash plate if maximum pressure and speed at which pump operates is 200 bar and 1000 rpm respectively. [6]

b) Explain with neat sketch pressure compensated flow control valve. [4]

Q2) Draw the suitable pneumatic circuit using cascade system to actuate cylinder 'A', cylinder 'B' and cylinder 'C' as per following sequence: [10]

- i) Cylinder A extends
- ii) Cylinder B extends
- iii) Cylinder C extends
- iv) Cylinder A retracts
- v) Cylinder C retracts
- vi) Cylinder B retracts

P.T.O.

- Q3)** Write short notes on :
- a) Design aspects of hydraulic accumulator. [5]
 - b) Selection criteria for P, PI, and PID controllers. [5]
- Q4)** a) A feeder selector device at one of the stations of an automatic assembly machine has a feed rate of 25 parts /min and provides a throughput of one part in four. The ideal cycle time of the machine is 10 sec. The feeder stops for 20 parts in feed track and will starts while 10 parts in feed track. Determine how long will it take for the feeder to turn on once it is turned off and how long it will take to turn off once it is turned on? [6]
- b) List out the different types of Feeder. [4]
- Q5)** Write a short note on following :
- a) Automated Guided Vehicles. [5]
 - b) Design aspects of hydraulic accumulator. [5]
- Q6)** a) Give selection criteria of Robot and sensor used for welding application.[5]
- b) Explain robot programming Languages. [5]
- Q7)** Explain the Concept of the following :
- a) Selection criteria for P, PI and PID controllers. [5]
 - b) Working Principle of PLC. [5]
- Q8)** Write short notes on :
- a) Performance analysis of Material Handling System. [5]
 - b) Collision free motion planning for robots. [5]



Total No. of Questions : 08]

SEAT No. :

PA-795

[Total No. of Pages : 2

[5928]-306

M.E. (Production) (Manufacturing & Automation)

ADDITIVE MANUFACTURING

(2017 Pattern) (Semester - II) (511109)

Time : 3 Hours]

[Max. Marks : 50

Instructions to the candidates:

- 1) *Attempt Q.1 or Q.2, Q.3 or Q.4, Q.5 or Q. 6 and Q.7 or Q. 8.*
- 2) *Neat diagrams must be drawn wherever necessary.*
- 3) *Figures to the right side indicate full marks.*
- 4) *Use of calculator is allowed.*
- 5) *Assume suitable data if necessary.*

Q1) a) What is additive manufacturing? What are its advantages and disadvantages? [4]

b) Enlist various powder based rapid prototyping system explain any one of them in short. [5]

OR

Q2) a) Explain the role of additive manufacturing in product development. [4]

b) Enlist various solid based rapid prototyping system explain any one of them in short. [5]

Q3) a) Write short note on model slicing. [4]

b) Explain the different properties of prototype. [5]

OR

Q4) a) Explain the model reconstruction in additive manufacturing. [4]

b) Explain with neat sketch different steps in additive manufacturing. [5]

Q5) a) Explain the Selective Laser Sintering with reference to its working process advantages and disadvantages. [8]

b) Explain the medical and Bio-Additive manufacturing with its applications, advantages and disadvantages. [8]

OR

P.T.O.

- Q6)** a) Explain the STL FORMAT in Rapid Prototyping, what are its advantages and disadvantages. [8]
b) Write short note on processing of additive manufacturing parts. [8]

- Q7)** a) Explain with neat sketch the Electron Beam Melting process. [8]
b) Write short note on Fused deposition modeling. [8]

OR

- Q8)** a) Explain the Stereo-lithography with reference to its working process, advantages and disadvantages. [8]
b) Write short note on Computer Aided Tissue Engineering (CATE). [8]



Total No. of Questions : 6]

SEAT No. :

PA-796

[5928]- 307

[Total No. of Pages : 2

**M.E. (Production Engineering) (Manufacturing & Automation)
MECHATRONICS
(2017 Pattern) (Semester - III) (611102)**

Time :3 Hours]

[Max. Marks : 50

Instructions to the candidates:

- 1) *Q. No. 5 and Q. No.6 are compulsory.*
- 2) *Neat diagrams must be drawn wherever necessary.*
- 3) *Figures to the right indicate full marks.*
- 4) *Use of non-programmable calculator is allowed.*
- 5) *Assume suitable data, if necessary.*

- Q1) a)** Discuss the significance of mechatronics in manufacturing industry. **[5]**
b) Describe the working of optical encoder with a neat sketch. **[5]**

OR

- Q2) a)** Describe the principle of tactile sensor with application. **[5]**
b) A 360° wire-wound potentiometer has 400 turns and a total resistance of 1 kΩ. What is the resolution in ohms? In degrees? **[5]**
- Q3) a)** Explain significance of carry flags in a microprocessor. **[4]**
b) Develop a conceptual design of a sensors based control system for an electronic toaster. Assume suitable data if necessary. **[6]**

OR

- Q4) a)** Write the instructions to load two hexadecimal numbers 69D and 70C in the registers A and B respectively. Add the numbers, and store the result in memory location 607B. **[6]**
b) Explain ADC (Analog to Digital Conversion). **[4]**

P.T.O.

Q5) a) Construct the ladder logic diagrams for **[6]**
i) the AND gate and
ii) the Ex-NOR gate. Also develop a truth table for both logics.

b) Explain application of PLC system for drilling application. **[9]**

Q6) Write short notes on the following. **[15]**

- a) Pin configuration of microprocessor
- b) PID controllers
- c) Microcontroller



Total No. of Questions : 8]

SEAT No. :

PA-605

[5928]- 32

[Total No. of Pages : 3

M.E. (Civil) (Hydraulics Engineering)
OPEN CHANNEL HYDRAULICS
(2017 Pattern) (Semester - II) (501047)

Time : 3 Hours]

[Max. Marks : 50

Instructions to the candidates:

- 1) *Answer Q.1 or Q.2, Q.3 or Q.4, Q.5 or Q.6, Q.7 or Q.8.*
- 2) *Neat diagrams must be drawn wherever necessary.*
- 3) *Figures to the right indicate full marks.*
- 4) *Assume suitable data, if necessary.*
- 5) *Use of calculator is allowed.*

- Q1) a)** A rectangular channel is 3.0 m wide and carries a discharge of 15 m³/s at a depth of 2.0 m. At a certain section of the channel, it is proposed to reduce the width to 2.0 m and to alter the bed elevation by ΔZ to obtain critical flow at the contracted section without altering upstream depth. What should be the value of ΔZ ? **[5]**
- b)** Water from a low dam is released through a sluice gate on a horizontal rectangular channel. The depth of water upstream of the sluice gate is 16.0 m above the channel bed and the gate opening is 1.5 m. The sluice gate can be assumed to be sharp edged. If a free hydraulic jump is formed just downstream of the gate, find the sequent depths and the percentage of the initial energy lost in the jump. **[4]**

OR

- Q2) a)** Explain **[4]**
- i) Specific energy diagram
 - ii) Specific force diagram
- b)** At the bottom of a spillway the velocity and depth of flow are 12.0 m/s and 1.5 m respectively. If the tail water depth is 5.5 m find the location of the jump with respect to the toe of the spillway. What should be the length of the apron to contain this jump?
Assume the apron to be horizontal and Manning's $n = 0.015$. **[5]**
- Q3) a)** Explain characteristics of S_1 , S_2 and S_3 profiles. **[5]**
- b)** A side channel spillway channel is 100m long and is rectangular in cross section with $B = 5.0\text{m}$, $n = 0.02$, $\beta = 1.30$ and $S_0 = 0.15$. If the lateral inflow rate is 1.75 m³/s/m, find the critical depth and its location. **[4]**

OR

P.T.O.

Q4) a) Show that in a wide rectangular critical slope channel the gradually varied flow profiles calculated by using Chezy formula with $C = \text{constant}$ are horizontal lines. [5]

b) A rectangular channel is 2.0 m wide and carries a flow of 3 m³/s at a depth of 0.9 m. At a certain location in this channel a uniformly discharging side weir is proposed to divert 0.3 m³/s of flow laterally. The weir crest is horizontal and is placed at a height of 0.65m above the bed at the commencement of the side weir. Calculate the length of the side weir and other dimensions of the channel geometry to achieve the objective. [4]

Q5) a) A wide tidal river has a low water velocity of 1.5 m/s and a depth of 2.5 m. A tide in the sea causes a bore which travels upstream.

i) If the height of the bore is 0.9 m, estimate the speed of the bore and the velocity of flow after its passage.

ii) If the bore is observed to cover a distance of 2.5 km in 10 minutes determine its height. [8]

b) Show that in a positive surge moving down a rectangular channel with absolute velocity V_w , the depths before the passage of the surge y_1 and after the passage of the surge y_2 are related as

$$\frac{y_2}{y_1} = \frac{1}{2} \left[-1 + \sqrt{1 + 8F_a^2} \right]$$

Where $F_a^2 = \frac{(V_w - V_1)^2}{gy_1}$ and $V_1 = \text{absolute velocity in the channel before the passage of the surge.}$ [8]

OR

Q6) a) A positive surge is often known as a moving hydraulic jump. Obtain an expression in terms of depths y_1 and y_2 for the energy loss in a moving hydraulic jump in a horizontal rectangular channel. [8]

b) A rectangular channel carries a discharge of 1.5 m³/s/m width at a depth of 0.75 m. If the sudden operation of a sluice at an upstream section causes the discharge to increase by 33 per cent, estimate the height and absolute velocity of the positive surge in the channel. [8]

Q7) a) Distinguish between: i) hydraulic and hydrologic method of flood routing, ii) hydrologic storage routing and hydrologic channel routing, iii) prism storage and wedge storage. [7]

b) A small reservoir has the following storage elevation relationship. [9]

Elevation (m)	55	58	60	61	62	63
Storage (10^3 m^3)	250	650	1000	1250	1500	1800

A spillway provided with its crest at elevation 60.00 m has the discharge relationship $Q = 15H^{3/2}$, where H = head of water over the spillway crest. When the reservoir elevation is at 58.00 m a flood as given below enters the reservoir. Route the flood and determine the maximum reservoir elevation, peak outflow and attenuation of the flood peak.

Time (hr)	0	6	12	15	18	24	30	36	42
Inflow(m^3/s)	5	20	40	60	50	32	22	15	10

OR

Q8) a) Describe a numerical method of hydrologic reservoir routing. [7]

b) A small reservoir has a spillway crest at elevation 200.00 m. Above this elevation, the storage and outflow from the reservoir can be expressed as:

Storage: $S = 36000 + 18000 y(\text{m}^3)$

Outflow: $Q = 10 y(\text{m}^3/\text{s})$

Where y = height of the reservoir level above the spillway crest in m. Route an inflow flood hydrograph which can be approximated by a triangle as

$I = 0$ at $t = 0$ h

$I = 30\text{m}^3/\text{s}$ at $t = 6$ h (peak flow)

$I = 0$ at $t = 26$ h (end of inflow).

Assume the reservoir elevation as 200.00m at $t = 0$ h. Use a time step of 2 h. [9]



Total No. of Questions : 8]

SEAT No. :

PA-606

[Total No. of Pages : 2

[5928]-33

M.E (Civil) (Hydraulics)

SEDIMENT TRANSPORT & RIVER MECHANICS

(2017 Pattern) (Semester - II) (501048)

Time : 3 Hours]

[Max. Marks : 50

Instructions to the candidates:

- 1) Solve any Five questions from Eight questions.
- 2) All questions carry equal marks.
- 3) Figures to the right indicate full marks.
- 4) Use of scientific calculator is allowed,
- 5) Assume suitable data if necessary.

- Q1)** a) What are the Bulk properties of sediment. [5]
b) Illustrate bed forms like ripples and dunes with characteristics. [5]
- Q2)** a) Write short note on Bed Formations. [5]
b) Explain resistance analysis related to Regimes of flow. [5]
- Q3)** a) Using Meyer-Peter and Muller method, estimate the bed 'load transport of sediment in an alluvial channel, 120 m wide and 4.2 m deep carrying a discharge of 295 m³/s. The channel bed slope is 1 in 3500 and the mean size of the sediment is 0.3 mm. [7]
b) What do you mean by suspended load, total load and wash load? [3]
- Q4)** a) Compare Kennedy method and Lacey method for the design of an irrigation channel giving in detail all the steps of the design. [5]
b) Explain "Saltation mechanism" [5]

P.T.O.

- Q5) a) Explain :** [5]
i) Agradation
ii) Degradation
b) What is river gauging? Explain the methods of river gauging in detail.[5]
- Q6) a) Write a short note on “Siltng of reservoir”.** [5]
b) Explain in detail River training for flood control. [5]
- Q7) a) What are the preventive & protective measures of sediment control?[5]**
b) Explain “Guiding the flow”. [5]
- Q8) a) Enlist the different river models & discuss any one of them.** [5]
b) Explain Sediment transport through pipes, considering the following points. [5]
i) Critical velocity
ii) Head Losses



Total No. of Questions : 8]

SEAT No. :

PA-607

[5928]-35

[Total No. of Pages : 2

M.E. (Civil-Hydraulics Engineering)
OPTIMIZATION TECHNIQUES
(2017 Credit Pattern) (Semester -III) (601051)

Time : 3 Hours]

[Max. Marks : 50

Instructions to the candidates:

- 1) Attempt Q1 or Q2, Q3 or Q4, Q5 or Q6 or Q7 or Q8.
- 2) Neat diagram must be drawn wherever necessary.
- 3) Figures to the right indicate full marks.
- 4) Assume suitable data if necessary and clearly state.
- 5) Use of cell phone is prohibited in the examination hall.
- 6) Use of non programmable electronic pocket calculator is allowed.

Q1) Use two phase simplex method to maximize.

[14]

$$Z = 5x_1 + 3x_2$$

Subject to the constraints, $2x_1 + x_2 \leq 1,$

$$x_1 + 4x_2 \geq 6,$$

$$x_1, x_2 \geq 0$$

OR

Q2) Five lectures by experts are to be scheduled so as not to conflict with one another. The lectures are to be delivered in the afternoon on week days only, otherwise, because of other close schedules, certain students will be forced to drop out these lectures. The following table or matrix indicates the number of absentees lecture wise and day wise. Schedule these lectures in such way as minimize the total number of students forced to remain absent. [14]

Lectures

Day	1	2	3	4	5
Mon	3	2	3	9	10
Tues	11	5	9	10	2
Wed	1	3	8	2	4
Thu	8	11	10	5	2
Fri	8	6	5	6	9

Table 2 Absentees Vs Lectures

Q3) Use method of Lagrangian multipliers to solve the following NLPP. Does the solution maximize or minimize objective function? [12]

$$\text{Optimize } Z = 2x_1^2 + x_2^2 + 3x_3^2 + 10x_1 + 8x_2 + 6x_3 - 100$$

$$\text{Subject to } x_1 + x_2 + x_3 = 20,$$

$$x_1, x_2, x_3 \geq 0$$

OR

P.T.O.

Q4) Maximize: **[12]**

$$F(x) = X/2 \text{ for } X \leq 2$$

$$-X + 3 \text{ for } X \geq 2$$

In the interval (0,3) by Fibonacci method using $N = 6$.

Q5) Maximize $Z = 50x_1 + 100x_2$ **[12]**

S.t. $10x_1 + 5x_2 \leq 2500,$

$$4x_1 + 10x_2 \leq 2000,$$

$$x_1 + \frac{3}{2}x_2 \leq 450,$$

$$x_1, x_2 > 0.$$

OR

Q6) a) Discuss in detail characteristics of Dynamic Programming. **[6]**

b) Discuss the procedure adopted in the analysis of Dynamic programming problems. **[6]**

Q7) a) A person repairing total station equipment finds that the time spent on the total station sets has exponential distribution with mean 20 minutes. If the total stations are repaired in the order in which they come in and their arrival is approximately Poisson with an average rate of 15 for 8-hour day, what is the repairman's expected idle time each day? How many jobs are ahead of the average set just brought in? **[10]**

b) Explain in brief Monte Carlo Simulation. **[2]**

OR

Q8) a) Reduce the following game by dominance property and solve it. **[12]**

		Palyer B				
		I	II	III	IV	V
Player A	I	1	3	2	7	4
	II	3	4	1	5	6
	III	6	5	7	6	5
	IV	2	0	6	3	1

★ ★ ★

Total No. of Questions : 8]

SEAT No. :

PA-608

[Total No. of Pages : 2

[5928]-36

M.E. (Civil) (Hydraulics Engineering)
RESEARCH METHODOLOGY
(2017 Pattern) (Semester - III) (601052)

Time : 3 Hours]

[Max. Marks : 50

Instructions to the candidates:

- 1) *Answer Q.1 or Q.2, Q.3 or Q.4, Q.5 or Q.6, Q.7 or Q.8.*
- 2) *Neat diagrams must be drawn wherever necessary.*
- 3) *Figures to the right side indicate full marks.*
- 4) *Assume suitable data if necessary and clearly state.*

Q1) a) Write a note on sources of research problem. [5]

b) What is the need of literature survey? Explain. [4]

OR

Q2) a) Explain Individual and Institutional research proposal. [5]

b) What are the sources of literature in research? Explain. [4]

Q3) a) Write a note on sampling size and sampling strategy. [5]

b) Explain variance technique. [4]

OR

Q4) a) What are the methods of data collection? Explain. [5]

b) What do you mean by testing of hypothesis? [4]

Q5) a) Explain with an example Correlation and regression analysis. [8]

b) What do you mean by Cluster analysis? Explain. [8]

P.T.O.

OR

Q6) a) What do you mean by discriminant analysis? Explain. [8]

b) Explain multidimensional measurement and factor analysis. [8]

Q7) a) Explain the need of effective documentation and report writing. [8]

b) Write a note on elements of effective presentation and impact of presentation. [8]

OR

Q8) a) Write a note on plagiarism and presentation styles. [8]

b) Explain the points to be considered in writing, presenting and publishing a of research paper. [8]



Total No. of Questions : 8]

SEAT No. :

PA-609

[Total No. of Pages : 2

[5928]-37

M.E. (Civil) (Structures Engineering)
THEORY OF ELASTICITY AND PLASTICITY
(2017 Pattern) (Semester - I) (501001)

Time : 3 Hours]

[Max. Marks : 50

Instructions to the candidates :

- 1) *Solve Q1 or Q2, Q3 or Q4, Q5 or Q6, Q7 or Q8.*
- 2) *Neat diagram must be drawn wherever necessary.*
- 3) *Figures to the right indicate full marks.*
- 4) *Assume suitable data, if necessary and clearly state.*

Q1) a) Give that the following strains exist at a point in a 3-D system, determine the equivalent stresses which act at the point. Take $E = 200 \text{ GPa}$ and $\mu = 0.03$ Also find the Lamé's constant. [5]

$$\varepsilon_x = 0.003; \gamma_{xy} = 0.0001$$

$$\varepsilon_y = 0.0008; \gamma_{yz} = 0.0005$$

$$\varepsilon_z = 0.0007; \gamma_{zx} = 0.0002$$

b) Derive the stress. strain relationship in polar coordinate system. [4]

OR

Q2) a) Check if the function $10x^4 + 15x^2y^2 - 15y^4$ is an Airy's stress function.[5]

b) Derive the strain displacement relationship in polar coordinate system.[4]

Q3) a) Derive the torsion formula for elliptical cross section of boundary condition

$$\text{as } \frac{x^2}{a^2} + \frac{y^2}{b^2} = 1. \quad [5]$$

b) What is axisymmetric problem? Explain its stress and strain distribution. [4]

OR

P.T.O.

- Q4)** a) Determine the shear stresses and angle of twist in an elliptical bar at the point (10, 20) whose semi-axes are (100,0) mm and (0,50) mm respectively. Give $T = 10$ kNm and $G = 70$ kN/mm². [5]
- b) Derive the torsion formula for rectangular cross section of size (a, b) using Prandtl's stress function as $\phi = \rho(x^2 - c^2)(y^2 - d^2)$ [4]

- Q5)** a) Explain in brief Tresca's failure criteria with suitable example. [8]
- b) Explain in brief Von Mises Henky failure criteria with relevant example. [8]

OR

- Q6)** a) Write as short notes on Bauschinger effect of stress strain. [8]
- b) Write short notes on Plastic bending and Torsion in elasto-plastic materials. [8]

- Q7)** a) State the behavior of ideally plastic thick walled cylinders under internal pressure alone with plane stress condition. [8]
- b) Derive the expression for solid cylindrical bar under torsion as per Nadia's Sand Heap analogy. [8]

OR

- Q8)** a) State the behavior of ideally plastic thick walled cylinders under internal pressure alone with plane strain condition. [8]
- b) Discuss the behavior of continuous beam plastic collapse in details with a suitable example. [8]



[5928]-38

M.E. (Civil) (Structure Engineering)
STRUCTURAL DYNAMICS
(2017 Pattern) (Semester - I) (501002)

Time : 3 Hours]

[Max. Marks : 50

Instructions to the candidates:

- 1) *Answer Q. 1 or Q. 2, Q. 3 or Q. 4, Q.5 or Q. 6 and Q. 7 or Q. 8.*
- 2) *Figures to the right indicate full marks.*
- 3) *If necessary, assume suitable data and indicate clearly.*
- 4) *Use of electronic pocket calculator is allowed.*

Q1) a) Derive the expression for calculating the equivalent damping coefficient. [5]

b) Prove that the angle of inclination does not affect the equation of motion of a SDOF system. [4]

OR

Q2) a) Derive the equivalent stiffness for the system shown in Fig. 1. [5]

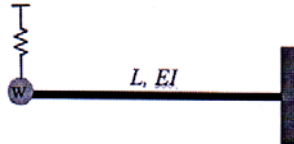

Fig. 1

b) Derive the expression for logarithmic decrement. [4]

Q3) Determine the damping factor for a system subjected to a particular vibration displacement amplitude where the free vibration trace is measured as 80% of the preceding amplitude. [9]

OR

Q4) In an un-damped SDOF system, a mass of 4.5 kg and a spring stiffness of 3 N/m is excited by a harmonic force. The harmonic force has an amplitude of 100 N and a frequency of 18 rad/s. The initial conditions for displacement and velocity are 0 and 150 mm/s respectively. Determine the frequency ratio, the amplitude of response, the displacement at $t = 1$ s and velocity at $t = 5$ s. [9]

P.T.O.

Q5) a) Write a note on piece-wise linear acceleration method, constant acceleration method, average acceleration method. [8]

b) Find the response for a SDOF system subjected to a loading as shown in Fig. 2. [8]

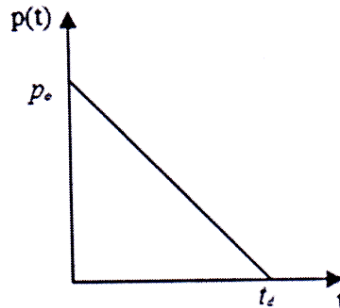

Fig. 2

OR

Q6) a) Determine the natural frequencies and plot the mode shapes for the building shown in Fig. 3. [8]

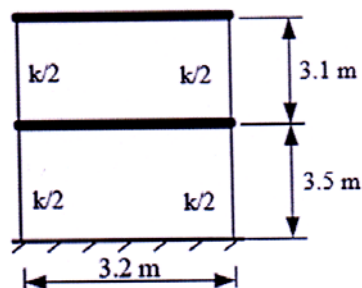

Fig. 3

b) Determine the natural frequencies and mode shapes for the system shown in Fig. 4. [8]

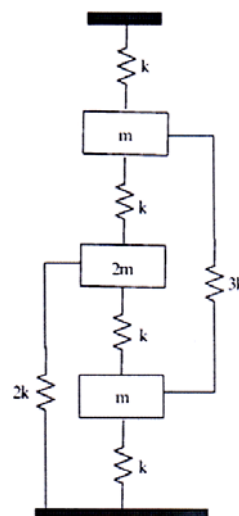

Fig. 4

- Q7)** a) Find the natural frequencies and the free-vibration solution of a beam simply supported at its ends. [8]
- b) From the fundamental principles, derive the equation of motion for transverse vibration of beam. [8]

OR

- Q8)** a) Derive the expression for natural frequency for a beam element using the Rayleigh's method. [8]
- b) Applying Rayleigh's method, determine the fundamental frequency of a cantilever beam. [8]



[5928]-39

M.E. (Civil - Structure Engg.)

ADVANCED DESIGN OF STEEL STRUCTURES

(2017 Pattern) (Semester - I) (501003)

Time : 3 Hours]

[Max. Marks : 50

Instructions to the candidates:

- 1) Answer Q. 1 or Q. 2, Q. 3 or Q. 4, Q. 5 or Q. 6, Q. 7 or Q. 8.
- 2) Neat diagrams must be drawn wherever necessary.
- 3) Figure to the right indicates full marks.
- 4) Assume suitable data if necessary.
- 5) IS : 800 - 2007, IS : 800 - 1984, IS : 801, IS : 802, IS 811, SP - 34 and Nonprogrammable calculator.

- Q1)** a) What is mean by microwave tower, write down steps to design microwave tower. [3]
- b) The design factored forces coming in member of a hording structure are 110 KN tensile force, and 65kN compressive force. Design a double unequal angle section back to back on opposite faces of 8 mm thick gusset plate with M20 black bolt of 4.6 grade of steel. Take length of member as 2.3m c/c. Draw the design sketch. [6]

OR

- Q2)** a) Highlight the advantages of tubular sections over conventional steel sections. [3]
- b) Determine the lateral forces due to wind, longitudinal force, if any, torsional forces, if any and dead load acting on tower shown in figure under Normal operating conditions. [6]

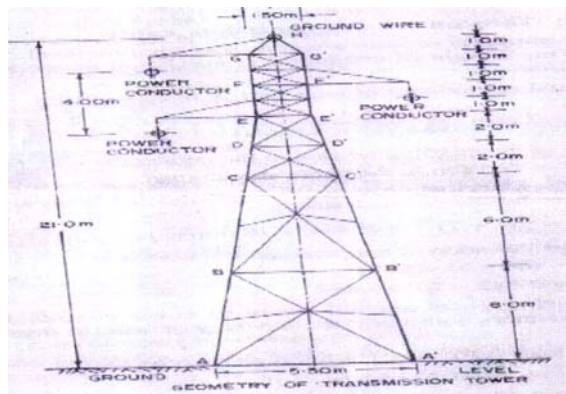

- Q3)** a) What is local buckling? Explain with a suitable example. [3]
b) Explain broken wire condition and uplift. [6]

OR

- Q4)** a) Explain with neat sketches the various types of transmission towers. [3]
b) Design a beam using light gauge section to carry an udl of 5kN/m (inclusive of self weight) over a simply supported span of 5m. [6]

- Q5)** a) A steel chimney of 72 m height and the diameter of cylindrical shell is 3m. The moment at the base of chimney is 8830kNm and the weight of chimney shell is 756kN. It has a 100mm thick lining brick lining. Design base Plate and Anchor bolt. [8]
b) Explain how the height and other dimensions of a steel chimney are determined. [8]

OR

- Q6)** a) What forces act on the base plate of steel chimney? Explain the design procedure of base plate. [8]
b) State and explain in details stability of steel chimneys. [8]

- Q7)** a) State and explain different design forces for the chimney. [8]
b) State and explain different lining materials for chimney. [8]

OR

- Q8)** A self supporting steel stack is 72mts high and its top diameter is 3m is to be designed for Pune. Design the plates of stack, base plate of stack and anchor bolt. [16]



Total No. of Questions : 8]

SEAT No. :

PA-581

[Total No. of Pages : 2

[5928]-4

M.E. (Civil) (Construction & Management)
TOTAL QUALITY MANAGEMENT IN CONSTRUCTION
(2017 Credit Pattern) (501024) (Semester - I)

Time : 3 Hours]

[Max. Marks : 50

Instructions to the candidates:

- 1) *Attempt Q.1 or Q.2, Q.3 or Q.4, Q.5 or Q.6 and Q.7 or Q.8.*
- 2) *Neat diagrams must be drawn wherever necessary.*
- 3) *Figures to the right indicate full marks.*
- 4) *Assume suitable data, if necessary and clearly state.*
- 5) *Use of cell phone is prohibited in the examination hall.*
- 6) *Use of electronic pocket calculator is allowed.*

Q1) a) Explain PDCA Cycle. [4]

b) Explain the application of dispersion methods in quality control. [5]

OR

Q2) a) Explain the need and Importance of TQM in construction sector. [4]

b) Write note on Pareto diagram and Fishbone diagram. [5]

Q3) a) Explain the need of training and development of human resources. [4]

b) Explain the concept of 360° feedback for quality. [5]

OR

Q4) a) Write note on training on project rework reduction tool. [5]

b) Explain the role of quality inspection team. [4]

Q5) a) State the difference between ISO 9001 and 9004. [8]

b) Explain the certification process of ISO 9001. [8]

OR

P.T.O.

- Q6)** a) Explain the principles of ISO. [8]
b) Write short note on ISO 9004. [8]

- Q7)** a) Explain the various types of construction defects. [8]
b) What are the remedial strategies for NCR's. [8]

OR

- Q8)** a) What is third party audits and explain the importance of it. [8]
b) Write note on CIDC-CQRA quality rating systems. [8]



Total No. of Questions : 8]

SEAT No. :

PA-612

[Total No. of Pages : 3

[5928]-40

M.E. (Civil - Structures)

**NUMERICAL METHODS IN STRUCTURAL
ENGINEERING**

(2017 Pattern) (Semester - I) (501004)

Time : 3 Hours]

[Max. Marks : 50

Instructions to the candidates:

- 1) *Answer Q. 1 or Q. 2, Q. 3 or Q. 4, Q. 5 or Q. 6 and Q. 7 or Q. 8.*
- 2) *Figures to the right indicate full marks.*
- 3) *If necessary, assume suitable data and indicate clearly.*
- 4) *Use of electronic pocket calculator is allowed.*

Q1) a) Explain the significance of transformation matrix. **[5]**

Determine the member stiffness matrix $[S_m]_G$ in global coordinates for element AB fixed at end B and the transformation matrix $[R]$ of element BC fixed at end C of the frame shown in Figure 1.

Take $E = 200 \text{ GPa}$, $A = 0.03 \text{ m}^2$, $I = 0.0003 \text{ m}^4$, $L = 4 \text{ m}$.

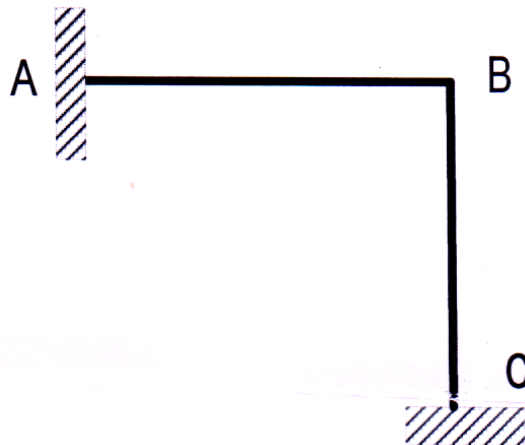

b) Explain Gauss elimination method, Gauss - Jordan method. **[4]**

OR

P.T.O.

- Q2)** a) For the given truss, derive the global stiffness matrix using Direct stiffness matrix. $AB = 4$ m, $AC = 3$ m, Take $E = 200$ GPa, $A = 0.03$ m². [5]

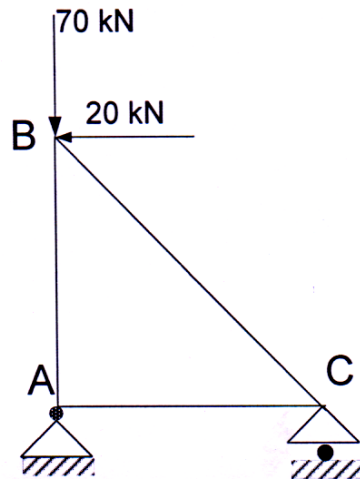

- b) Find Cholesky factorization for the given matrix; if possible. [4]

$$[A] = \begin{bmatrix} 4 & 3 & 1 \\ 2 & 3 & 3 \\ 1 & 3 & 1 \end{bmatrix}$$

- Q3)** a) Use power method to approximate a dominant eigenvalue and the corresponding eigenvector of $\begin{bmatrix} 4 & -5 \\ 2 & 3 \end{bmatrix}$ correct to 3-significant figures, after 4 iterations. Begin with an initial nonzero approximation of $[x_0] = \begin{bmatrix} 1 \\ 1 \end{bmatrix}$. [5]

- b) Write a short note Gauss Quadrature method for numerical integration. Explain with illustration. [4]

OR

- Q4)** a) Solve the following initial value problem using fourth order Runge

Kutta method $\frac{d^2 y}{dx^2} + 0.4 \left(\frac{dy}{dx} \right)^2 + 6y = 0$ with initial conditions $y(0) = 5$

and $\frac{dy}{dx} = 0$. Start at $x = 0$ and find $y(2)$. [5]

- b) Explain the Gauss Quadrature rule of Integration. Integrate $f(x) = 3x^3 - 4x^2 + 4x - 5$ from -2 to 4 using Gauss Quadrature formula.

[4]

- Q5)** a) A simply supported beam has a span of 4 m and is loaded with a couple of 1kNm at the center. Second moment of area of its cross section is '2I' for left half portion towards the fixed end and 'I' for right half portion. Using nodes at 1 m interval, calculate the deflection and bending moment at the center using finite difference method. [8]
- b) A simply supported uniform plate of length 4 m and width 2 m supports a central point load of 12 kN along with uniformly distributed load 3 kN/m² over the entire plate. Using finite difference method, estimate the deflection at the nodal points of the grid, using grid interval of $h = 1\text{m}$. [8]

OR

- Q6)** a) Using finite difference method, estimate the buckling load of a pin ended column of length L and uniform cross section. Consider four subinterval and compare the approximate value obtained with the exact value given by Euler's critical load theory. [8]
- b) Find deflection at the four interior nodal points using finite difference method for a simply supported square plate of size 2 m. The plate supports a uniformly distributed load of intensity 3 kN/m². Divide the plate into nine equivalent squares. [8]

- Q7)** a) Fit an model ($y=a*x/(b+x)$) to the data given below. [8]

X	2	4	6	8
Y	1.5	2.1	2.5	2.7

- b) Write a short note on curve fitting techniques. [8]

OR

- Q8)** a) Fit a curve using least square method and find the functional value at $x=0.6$. [8]

X	2	4	6	8	10
Y	5.39943	6.59468	8.05501	9.83841	12.01666

- b) Write a short note on Spline Fit technique. [8]



Total No. of Questions : 8]

SEAT No. :

PA-1154

[Total No. of Pages : 2

[5928]-41A
M.E. (Civil) (Structures Engineering)
FINITE ELEMENT METHOD
(2017 Pattern) (Semester - II) (501007)

Time : 3 Hours]

[Max. Marks : 50

Instructions to the candidates :

- 1) *Answer Q.1 or Q.2, Q.3 or Q.4, Q.5 or Q.6, Q.7 or Q.8.*
- 2) *Neat diagrams must be drawn wherever necessary.*
- 3) *Figures to the right side indicates full marks.*
- 4) *Use of electronic pocket calculator is allowed.*
- 5) *Assume suitable data, if necessary.*

Q1) Write short note on :

[10]

- a) Galerkin Method
- b) Collocation Method
- c) Least Square Method
- d) Rayleigh-Ritz Method

OR

Q2) a) Explain the difference between CST and LST elements with suitable example. **[5]**

b) Draw 2D and 3D Pascal's triangle and explain geometric invariance. **[5]**

Q3) a) Using variation approach, derive stiffness matrix for two noded bar element. **[7]**

b) Derive shape functions for the three noded constant strain triangular (CST) element used in plane elasticity problem. Coordinates at nodes of CST element are (1, 2), (5, 3), (4, 6). **[7]**

OR

Q4) a) Using variation approach, derive stiffness matrix for two noded beam element. **[7]**

b) Derive area coordinates of three noded CST element considering 6 DOF. **[7]**

P.T.O.

- Q5) a)** Explain with suitable example [5]
- Sub-parametric elements and
 - Super-parametric elements
- b)** Determine the Cartesian coordinate (x, y) of the any point $P(\xi = 0.5, \eta = 0.6)$ as shown in figure. [8]

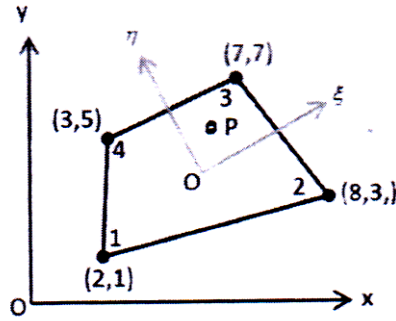

OR

- Q6)** Obtain Jacobean matrix for the quadrilateral element as shown in figure using isoperimetric formulation. [13]

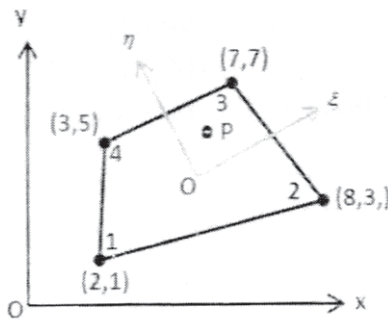

- Q7)** Derive stiffness matrix for the rectangular BFS plate bending element with 16 DOF. [13]

OR

- Q8) a)** Explain the term Mindlin's C^0 -continuity plate element and briefly explain stiffness matrix formulation for such elements. [6]
- b)** Explain briefly the various factors to be considered in the development of curved shell elements. [7]



Total No. of Questions : 8]

SEAT No. :

PA-614

[Total No. of Pages : 2

[5928]-42

M.E. (Civil) (Structures Engg.)
THEORY OF PLATES AND SHELLS
(2017 Pattern) (Semester - II) (501008)

Time : 3 Hours]

[Max. Marks : 50

Instructions to the candidates:

- 1) *Attempt Q. 1 or Q. 2, Q. 3 or Q. 4, Q.5 or Q. 6 and Q. 7 or Q. 8.*
- 2) *Neat diagram must be drawn wherever necessary.*
- 3) *Figure to the right indicates full marks.*
- 4) *Assume suitable data, if necessary and clearly state.*
- 5) *Use of cell phone is prohibited in the examination hall.*
- 6) *Use of electronic pocket calculator is allowed.*

- Q1)** a) Derive Relationship between Bending Moments and Curvature in Pure Bending of Plates. [6]
- b) Explain the difference between thin and thick plates. [3]

OR

- Q2)** a) Explain small deflection theory of thin plate's assumptions. [5]
- b) Describe in brief shear deformation theory and write the displacement function of Reissener - Mindlin theory. [4]

- Q3)** a) Explain membrane theory of cylindrical shell. [4]
- b) State and explain classification of shells on geometry with suitable sketches. [5]

OR

- Q4)** a) Derive differential Equations of Bending of Plates in Polar Coordinates. [5]
- b) Derive equilibrium equation for conical Shell of Constant Thickness. [4]

P.T.O.

- Q5)** a) Derive equation for A Circular Cylindrical Shell Loaded Symmetrically with Respect to Its Axis. [8]
b) Differentiate membrane and bending theory for circular cylindrical shell. [8]

OR

- Q6)** a) Derive expression for Cylindrical Shells with Supported Edges. [8]
b) State and Explain Bending theory of Cylindrical Shells. [8]

- Q7)** a) State and explain Lundgren's beam theory with its application to analysis of shells. [8]
b) Explain in details beam analysis for cylindrical shells. [8]

OR

- Q8)** a) Explain in brief beam method of analysis for cylindrical shells and applications to cylindrical roof shells. [8]
b) Explain in details arch analysis for cylindrical shells. [8]



Total No. of Questions : 8]

SEAT No. :

PA-615

[Total No. of Pages : 2

[5928]-43

M.E. (Civil) (Structure Engg.)

ADVANCED DESIGN OF CONCRETE STRUCTURES

(2017 Pattern) (Semester - II) (501009)

Time : 3 Hour]

[Max. Marks : 50

Instructions to the candidates:

- 1) *Answer Q.1 or Q.2, Q.3 or Q.4, Q.5 or Q.6, Q.7 or Q.8.*
- 2) *Neat diagrams must be drawn wherever necessary.*
- 3) *Figures to the right side indicate full marks.*
- 4) *Assume suitable data, if necessary.*
- 5) *Use IS 456, IS 1343, IS 1893, IS 3370, and Non-programmable calculator.*

Q1) a) Write a short note with sketches on characteristics of Yield lines. [4]

- b) Design a grid slab for a floor of hall 12m×15m having a square grid of 1.5m. Take live load 6kN/m² and floor finish load 1.4kN/m² Use M20 and Fe415 steel. [5]

OR

Q2) a) Draw yield line pattern for: A rectangular slab with fixed support on three sides with shorter side simply supported. [4]

- b) Design a grid slab for a floor of community hall 15m×18m having square grid of 1.5m. Take live load 4.5kN/m² and floor finish load 1.5kN/m² Use M20 and Fe415. [5]

Q3) a) Explain different types of flat slab and list the advantages of flat slab. [4]

- b) An open square tank 6m×6m×3m deep and supported 6m above the ground level on beams and columns. Design the beam and column of a tank. Use M20 and Fe500 steel. [5]

OR

Q4) a) Explain in detail wind load analysis of column for a water tank supported on four identical columns with their lower end fixed to the base. [4]

- b) Design a interior panel of flat slab for flexure with panel size 5.75m×5.75m in dimensions. Take live load of 5 kN/m² and floor finish load of 1.3kN/m². Use M20 and Fe500. [5]

P.T.O.

- Q5) a)** Design a circular bunker to store 60kN of coal take density of coal as 8kN/m^3 , angle of repose is 28° . Use M25 and Fe500 steel. Draw the details of reinforcement in side wall and hopper. [8]
- b) A concrete bin is $3.6\text{m} \times 3.6\text{m}$ and contains wheat weighing 9.55kN/m^3 . The coefficient of friction between grain and grain is 0.44 and the coefficient of friction between grain and concrete is 0.42. If the depth of wheat is 5m, determine the lateral pressure per meter run of the bin wall. [8]

OR

- Q6) a)** Design a square bunker to store 100 tons of cement, consider Unit weight of cement as 30kN/m^3 . Angle of repose is 29° . Use M25 and Fe500. Draw reinforcement details for side walls and hopper bottom. [8]
- b) A concrete storage bin is $5\text{m} \times 5\text{m}$ and contains wheat weighing 12.5kN/m^3 . The coefficient of friction between grain and grain is 0.42 and the coefficient of friction between grain and concrete is 0.40. If depth of wheat is 4.5m, determine the lateral pressure per meter run of the bin wall. [8]
- Q7) a)** A group of 30 piles are arranged in 5 rows and 6 in each row. The piles are 350mm in diameter and spaced 1.2m center to center. Each pile can carry 250kN load if it can act independently. Determine the carrying capacity of the pile group. [8]
- b) Design a formwork for a slab of $4.5\text{m} \times 4.5\text{m}$ having thickness of 180mm. It is proposed to deposit concrete in one stage. [8]

OR

- Q8) a)** In a group of 25 piles of diameter 400mm and center to center spacing of pile being 1.2m. The piles are arranged in square area. Each pile is 13m long and taking $m = 0.7$ and $c = 50\text{kN/m}^2$. Ascertain whether the failure will occur with the piles acting individually or as a group. Also specify the failure load. [8]
- b) Design a raft foundation for the following center to center distance of column in both directions is 2.4m. Taking column size as $300\text{mm} \times 300\text{mm}$, working load on each column is 600kN. The depth of strata is 1.5m. Use M25 and Fe500, SBC 100kN/m^2 . Draw reinforcement details. [8]



Total No. of Questions : 8]

SEAT No. :

PA-616

[Total No. of Pages : 2

[5928]-44

M.E. (Civil) (Structure)

RESEARCH METHODOLOGY

(2017 Course) (Semester - III) (601013)

Time : 3 Hours]

[Max. Marks : 50

Instructions to the candidates:

- 1) *Answer Q1 or Q2, Q3 or Q4, Q5 or Q6, Q7 or Q8.*
- 2) *Neat diagrams must be drawn wherever necessary.*
- 3) *Figures to the right indicate full marks.*
- 4) *Assume suitable data, if necessary.*

Q1) a) Points for developing research problem & hypothesis. [4]

b) Errors in research problem. [5]

OR

Q2) a) Using scientific method characteristics of research. [4]

b) Steps for publishing research paper. [5]

Q3) a) Objectives of literature review. [4]

b) Types of sampling design & note on probability sampling. [5]

OR

Q4) a) Importance of good literature review. [4]

b) Short note on Rating scales, Sampling techniques. Give examples for both. [5]

Q5) a) Different methods of factor analysis & explanation of any one method. [8]

b) Multicollinearity notes limitation of Regression analysis. [8]

OR

P.T.O.

- Q6)** a) Error in hypothesis testing for Type I & Type II. [8]
b) Distinguish between parametric & non parametric test in hypothesis testing. [8]

- Q7)** a) Patents usefulness for society Business Individuals. [8]
b) Problem of any Civil Engg. aspect and writing research proposal. [8]

OR

- Q8)** a) Steps involved in writing a report. [8]
b) Problem of structural Engg. to be defined & preparing Research proposal. [8]



Total No. of Questions : 8]

SEAT No. :

PA-617

[Total No. of Pages : 3

[5928]-45

M.E. (Civil-Structures)

**ANALYSIS AND DESIGN OF EARTHQUAKE RESISTANT
STRUCTURES**

(2017 Pattern) (Semester - III) (601014)

Time : 3 Hours]

[Max. Marks : 50

Instructions to the candidates:

- 1) *Attempt Q.1 or Q.2, Q.3 or Q.4, Q.5 or Q.6, Q.7 or Q.8.*
- 2) *Neat diagrams must be drawn wherever necessary.*
- 3) *Figures to the right indicate full marks.*
- 4) *Assume suitable data, if necessary and clearly state.*
- 5) *Use of cell phone is prohibited in the examination hall.*
- 6) *Use of electronic pocket calculator is allowed.*
- 7) *Is 1893 is allowed.*

Q1) a) What is a Richter scale? [5]

b) Write a short note on seismic zoning? [4]

OR

Q2) a) What is liquefaction? State its effect on structures. [5]

b) What is the Modified Mercalli Intensity Scale? [4]

Q3) a) Explain what twist does to building members. [5]

b) Define mass irregularities. [4]

OR

Q4) a) A building having non uniform distribution of mass in Fig. locate its center of mass [5]

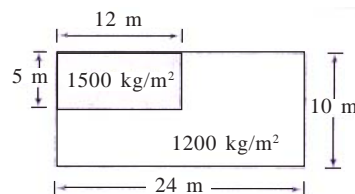

b) Explain capacity based design and performance based design. [4]

P.T.O.

- Q5)** a) Define code based procedure for seismic analysis. [10]
b) Explain detailing of beams as per IS code provisions. [6]

OR

- Q6)** a) Design and detailing of shear wall the shear wall of length 11.4 m and thickness 200mm. it is subjected to the following forces : [10]

Factored axial force $P_u = 8550$ kN

Factored Bending Moment = 47392.9 kN-m

Factored Shear force = 2063.2 kN

Material $F_{ck} = 25$ N/mm², $F_e = 415$ N/mm²

- b) Write a short note on : [6]
- i) Shaking table test
 - ii) Pseudo-dynamic test
 - iii) Quasi static test

- Q7)** a) State IS 3370 code provisions for water tanks. Write design procedure for water tank. [8]
b) Explain why buildings with shear walls preferred in seismic regions. Discuss the concept of flanged shear wall. [8]

OR

- Q8)** A RC circular water container of 50 m³ capacity has internal diameter of 4.65 m and height of 3.3 m (including freeboard of 0.3 m). It is supported on RC staging consisting of 4 columns of 450 mm dia with horizontal bracings of 300 × 450 mm at four levels. The lowest supply level is 12 m above ground level. Staging conforms to ductile detailing as per IS 13920. Staging columns have isolated rectangular footings at a depth of 2m from ground level. Tank is located on soft soil in seismic zone II. Grade of staging concrete and steel are M20 and Fe415, respectively. Density of concrete is 25 kN/m³. Analyze the tank for seismic loads upto base moment. [16]

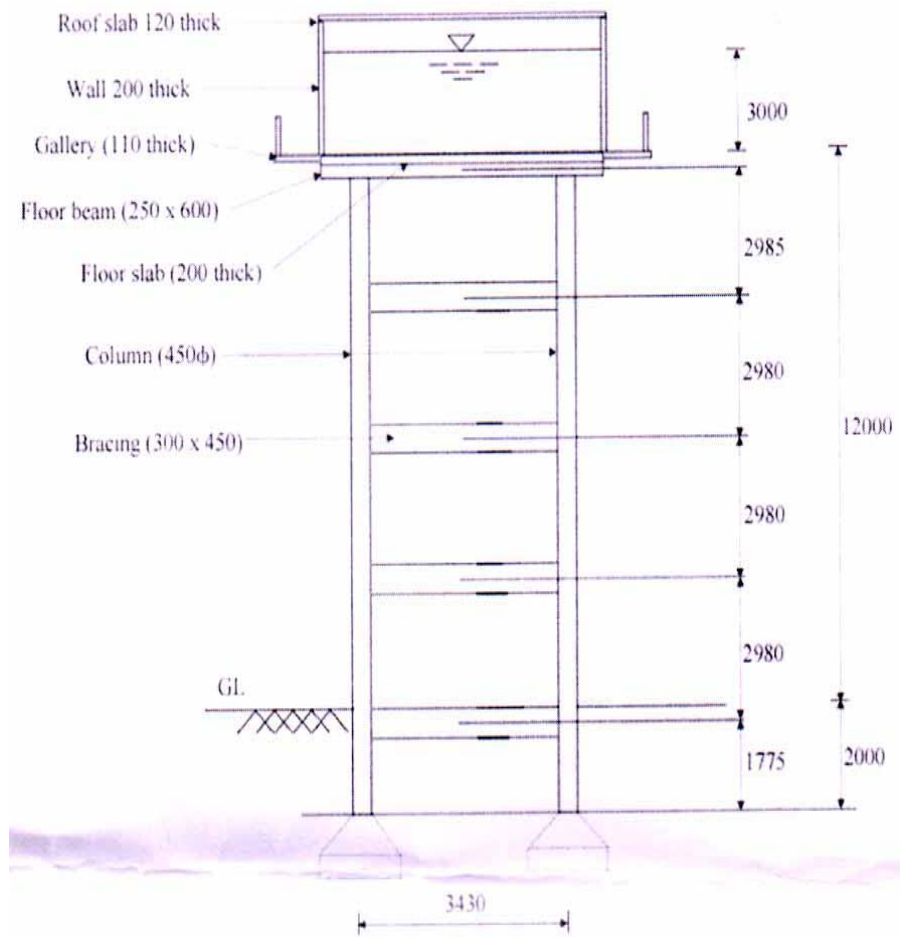

(a) Elevation

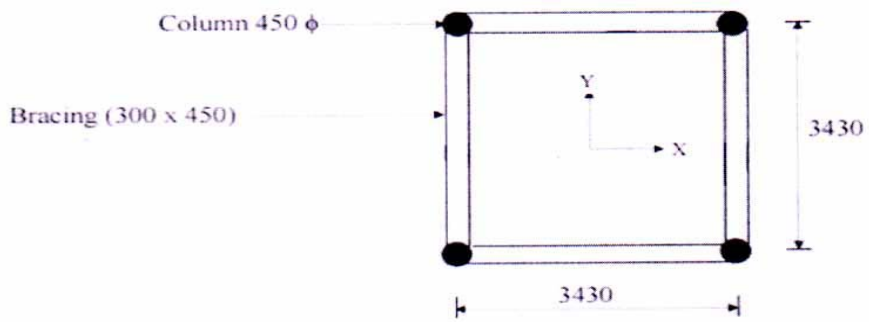

(b) Plan

(All dimensions in mm)



Total No. of Questions : 8]

SEAT No. :

PA-618

[Total No. of Pages : 2

[5928]-46

M.E. (Civil)

WATER RESOURCES AND ENVIRONMENTAL ENGG.
Planning and Management of Water Resources
(2017 Pattern) (Semester - I) (501081)

Time : 3 Hours]

[Max. Marks : 50

Instructions to the candidates:

- 1) *All questions are compulsory.*
- 2) *Neat diagrams must be drawn wherever necessary.*
- 3) *Figures to the right side indicate full marks.*
- 4) *Use of Calculator is allowed.*
- 5) *Assume Suitable data if necessary.*

- Q1)** a) State and explain objectives of management of water resources. [5]
b) Comment on spatial and temporal characteristics of water resources. [4]

OR

- Q2)** a) Explain constraints like reversibility for development of water resources. [5]
b) Explain objectives of water resources planning. [4]

- Q3)** a) Explain how conjunctive use of water play important role in water management. [4]
b) How can reservoir sedimentation be measured and monitored. [5]

OR

- Q4)** a) How groundwater content can be improved. [4]
b) Explain role of water doctrines to resolve disputes. [5]

P.T.O.

- Q5)** a) Comment on causes of floods, effects of flood and methods to control floods. [8]
b) Discuss central water policy with regards to water allocation. [8]

OR

- Q6)** a) Explain essential data necessary for water power studies for storage project. [8]
b) Explain repayment of cost and allocation of cost for multipurpose project. [8]

- Q7)** a) Explain financial performance analysis to check economic viability of long term sustainable projects. [8]
b) Explain in detail basin planning (principles & procedures). [8]

OR

- Q8)** a) Explain with an example Inter Basin Water Transfer. [8]
b) Explain discounting techniques for financial analysis of large dams. [8]



Total No. of Questions : 10]

SEAT No. :

PA-582

[Total No. of Pages : 2

[5928]-5

M.E. (Civil) (Construction & Management)
CONSTRUCTION CONTRACTS ADMINISTRATION AND
MANAGEMENT
(2017 Pattern) (Semester - II) (501027)

Time : 3 Hours]

[Max. Marks : 50

Instructions to the candidates:

- 1) *Answer Q.1 or Q.2, Q.3 or Q.4, Q.5 or Q.6, Q.7 or Q.8, Q.9 or Q.10.*
- 2) *Neat diagrams must be drawn wherever necessary.*
- 3) *Figures to the right side indicate marks.*
- 4) *Assume suitable data, if necessary.*
- 5) *Use of cell phone is prohibited in the examination hall.*
- 6) *Use of electronic pocket calculator is allowed.*

- Q1) a)** Explain with examples the valid excuses for non-performance permitted in the Indian Contract Act. [5]
- b) Define the role of project management services in construction project? [5]

OR

- Q2) a)** Explain in details standard forms of contracts & what is the importance of comparative statement after opening the Tenders? Give format for the same. [5]
- b) Explain Workmen's Compensation Act on construction projects with clauses. [5]
- Q3) a)** State the circumstances under which the lowest tender is rejected? [5]
- b) Circumstances under which the contractor shall be entitled to terminate the contract. [5]

OR

- Q4) a)** Discuss the advantages of DRB over dispute resolution mechanism. [5]
- b) Write in detail responsibilities and duties of the Employer for contracts under Red Book. [5]

P.T.O.

- Q5) a)** Explain Construction Claims, Types of construction claims and explain settlement of claims. [5]
- b) Write a brief meaning/Provision for following under FIDIC conditions RED BOOK. [5]
- i) Tests on completion & Tests after completion.
- ii) Employer's personnel & Contractor's personnel.

OR

- Q6) a)** Explain the different types of FIDIC books commonly used in projects and its uses? [5]
- b) Explain the Extra items and causes of claims in construction industry. [5]
- Q7) a)** Describe the clauses of escalation of cost: What is an arbitral proceeding. [5]

Explain with example.

- i) Escalation formula for Material cost.
- ii) Escalation formula for Labour cost.
- b) Explain in detail-importance of role of various stakeholders. [5]

OR

- Q8) a)** Explain in detail difference between 1940 Act and 1996? [5]
- b) What is the importance of role of various stakeholders in prevention of disputes? [5]
- Q9) a)** Define is Indian Arbitration and Conciliation Act 1996. [5]
- b) Explain the procedure of appealing against the awards? [5]

OR

- Q10) a)** Explain Conciliation and its provisions in the Act, also explain conduct of conciliation and arbitral proceedings? [5]
- b) Explain difference between Arbitration and Conciliation? [5]



Total No. of Questions : 8]

SEAT No. :

PA-619

[5928]- 50

[Total No. of Pages : 2

M.E. (Civil) (Water Resources And Environmental Engineering)

HYDROLOGY

(2017 Pattern) (Semester - II) (501087)

Time : 3 Hours]

[Max. Marks : 50

Instructions to the candidates:

- 1) *Answer all questions.*
- 2) *Neat diagrams must be drawn wherever necessary.*
- 3) *Figures to the right indicate full marks.*
- 4) *Use of Calculator is allowed.*
- 5) *Assume suitable data, if necessary.*

- Q1)** a) Explain hydrologic cycle. State various rain gauges. Explain in detail RADAR method. [5]
- b) Explain Stanford Watershed Model. [4]

OR

- Q2)** a) Draw a flow chart for mathematical methods in hydrology and explain stochastic hydrology applications. [6]
- b) Explain log- normal distribution (Statistical) [3]
- Q3)** a) What is design flood? How it is finalized while designing hydraulic structure. [4]
- b) Explain Pearson Type-III method. [5]

OR

- Q4)** a) Write note on method of images for ground water management. [5]
- b) Explain the Goodrich method of flood routing. [4]

P.T.O.

- Q5) a)** Explain step by step design of tube well & also explain types and construction methods for tube wells. [8]
- b) What are causes of ground water pollution? State effects of ground water pollution. What are the methods to treat polluted ground water?[8]

OR

- Q6) a)** What affects the quality of ground water in India. [8]
- b) Explain digital computer models. [8]

- Q7) a)** Explain any one widely used method of ground water recharge. [8]
- b) State various methods to conserve ground water and explain any two and also explain how it helps in management of water resources. [8]

OR

- Q8) a)** Explain electric analog model for ground water modeling with neat sketches. [8]
- b) Explain sand tank model and transparent model for ground water modeling with neat sketches. [8]



Total No. of Questions : 8]

SEAT No. :

PA-620

[Total No. of Pages : 2

[5928]-52

M.E. (Civil-Water Resources and Environmental Engineering)

ADVANCED WASTEWATER TREATMENT

(2017 Pattern) (501089) (Semester-II)

Time : 3 Hours]

[Max. Marks : 50

Instructions to the candidates:

- 1) *Solve Q1 or Q2, Q3 or Q4, Q5 or Q6 and Q7 or Q8.*
- 2) *Figures to the right indicate full marks.*
- 3) *Draw neat figures wherever necessary.*

Q1) a) Enlist and write difference between unit operation and unit process for secondary treatment. **[4]**

b) Explain kinetics of biological growth and substrate limited growth. **[5]**

OR

Q2) a) Write working principle and mechanism of membrane filtration. **[4]**

b) Enlist different membrane materials and modules. Explain any one. **[5]**

Q3) a) Write working principle and mechanism of micro filtration and nano filtration. **[4]**

b) Write design steps for membrane filtration. **[5]**

OR

Q4) a) Explain activated sludge process. **[4]**

b) Write short note on suspension mode plug flow reactor. **[5]**

Q5) a) Write working mechanism and design parameters and application of phytoremediation technology for wastewater treatment. **[8]**

b) Write sources of heavy metals and its reduction and effects. **[8]**

OR

P.T.O.

- Q6)** a) Write effluent standards for disposal of the sewage. [8]
b) Explain oxygen sag curve. [8]

- Q7)** a) Write principle, advantages and disadvantages of UASBR. [8]
b) Write short note on sludge thickeners and decanters. [8]

OR

- Q8)** a) Write methods of removal of nitrate and phosphate from the sludge and explain any one method. [8]
b) Write parameters to be considered in disposal of sewage for irrigation purpose. [8]



Total No. of Questions : 08]

SEAT No. :

PA-3160

[Total No. of Pages : 2

[5928]-54A

M.E. (Civil) (Water Resources and Environmental Engineering)

RESEARCH METHODOLOGY

(2017 Pattern) (Semester - III) (601094)

Time : 3 Hours]

[Max. Marks : 50

Instructions to the candidates:

- 1) Attempt Q. 1 or Q. 2, Q. 3 or Q. 4, Q.5 or Q. 6 and Q. 7 or Q. 8.
- 2) Figures to the right indicate full marks.
- 3) Your answers will be valued as whole.
- 4) Assume suitable data, if necessary.

- Q1)** a) Discuss the criteria's to be considered while formulation of research hypotheses. [5]
- b) Discuss the need to review the existing literature? [4]

OR

- Q2)** a) Define Exploratory research. Discuss a suitable example for the same.[5]
- b) Enlist various sources for Literature review and discuss the strategy to be employed for Applied research. [4]
- Q3)** a) Enlist different types of Sampling methods. Discuss an one type of sampling in detail with suitable example. [5]
- b) Discuss Type I and Type II error in research. [4]

OR

- Q4)** a) Discuss the conditions in which z-test and chi square test is used for Hypothesis testing. [5]
- b) Discuss the condition in which analysis of variance techniques is used in research with a suitable example. [4]

P.T.O.

- Q5)** a) Explain the characteristics of centroid method of Analysis and Principal Component Analysis. [8]
- b) Discuss the conditions in which descriptive statistics and inferential statistics will be used. [8]

OR

- Q6)** a) Discuss the important characteristics of factor Analysis and discriminant analysis. [8]
- b) Discuss Correlation and regression analysis. [8]

- Q7)** a) What are characteristics of good Abstract for a journal paper. Discuss as to why abstract is necessary. [8]
- b) Explain the need of filing a patent. elements of effective presentation.[8]

OR

- Q8)** a) A Technical project report must be submitted to a company. Discuss the report structure, report formulation for the same. [8]
- b) Discuss the need of effective documentation in research. [8]



Total No. of Questions : 8]

SEAT No. :

PA-622

[Total No. of Pages : 3

[5928]-55

M.E. (Mechanical)

(Design Engineering/Automotive E. & CAD,M&E)

ADVANCED MATHEMATICS

(2017 Credit Pattern) (Semester - I) (507201)

Time : 3 Hours]

[Max. Marks : 50

Instructions to the candidates:

- 1) Answer any five questions.
- 2) Neat diagrams must be drawn wherever necessary.
- 3) Figures to the right indicate full marks.
- 4) Use of logarithmic tables, electronic calculator is allowed.
- 5) Assume suitable data, if necessary.

Q1) a) Apply Gram - Schmidt method to given vectors to get an orthonormal basis. (1, 0, 1) (1, 0, -1), and (0, 3, 4). [5]

b) If $w = \phi + i\psi$ represents the complex potential for electric field and $\phi = 3x^2y - y^3$, determine the function ψ . [5]

Q2) a) Evaluate $\int_0^{2\pi} \frac{d\theta}{5 + 3\cos\theta}$ [5]

b) Solve the initial value problem in a mechanical system given by $\frac{d^2x}{dt^2} + 2\frac{dx}{dt} + 5x = e^{-t} \sin t$ where $x(0) = 0$ and $x'(0) = 1$ [5]

Q3) a) Find the Laplace transform of the function $f(t) = t^2 u(t - 3) - \cos ht. \delta(t - 3)$ [5]

b) Find the power series solution of $\frac{d^2y}{dx^2} - x\frac{dy}{dx} + x^2y = 0$. [5]

Q4) a) Find the Largest eigen value and corresponding Eigen vector of the matrix

$$A = \begin{bmatrix} 1 & 6 & 1 \\ 1 & 2 & 0 \\ 0 & 0 & 3 \end{bmatrix} \text{ taking } X_0 = \begin{bmatrix} 1 \\ 0 \\ 0 \end{bmatrix} \quad [5]$$

P.T.O.

- b) Given the values of $u(x, y)$ on the boundary of the square in the figure evaluate the function $u(x, y)$ satisfying Laplace equation $\frac{\partial^2 u}{\partial x^2} + \frac{\partial^2 u}{\partial y^2} = 0$. [5]

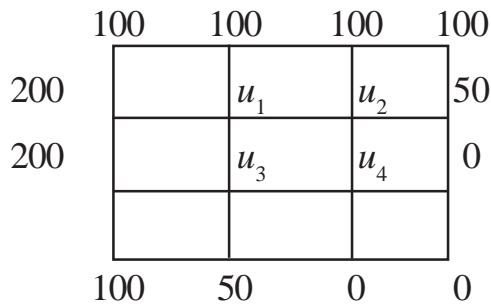

- Q5) a) Solve the boundary value problem $16 \frac{\partial u}{\partial t} = \frac{\partial^2 u}{\partial x^2}$ with boundary conditions

$u(0, t) = u(1, t) = 0, t > 0$ and $u(x, 0) = x(1 - x)$. Taking $h = \frac{1}{4}, k = \frac{1}{2}$ upto $t = 2$. [5]

- b) Use Galerkin method to obtain an approximate solution of the boundary value problem of mass spring system $y'' + y = x^2, (0 < x < 1) y(0) = y(1) = 0$. [5]

- Q6) a) Find the extremal of the functional $\int_0^1 (y^2 + (y')^2 + 2ye^x) dx$ $y(0)=y(1)=0$. [5]

- b) Solve the system of linear equation by least square method $x + y = 1, 2x + 2y = 3, 3x + 4y = 4$. [5]

- Q7) a) Find the image of the infinite strip $\frac{1}{4} \leq y \leq \frac{1}{2}$ under the transformation $w = \frac{1}{z}$. [5]

- b) Show that the fourier sine transform of the function $f(x) = e^{-|x|}$ is $\frac{s}{1+s^2}$.

Hence Evaluate $\int_0^{\infty} \frac{x \sin mx}{1+x^2} dx$. [5]

- Q8) a) For the system of masses and spring in the figure below $m_1 = 2$, $m_2 = 1$, $k_1 = 4$ and $k_2 = 2$, Assuming there is no friction. Find natural frequencies of the system and corresponding normal modes of vibration using matrix method [5]

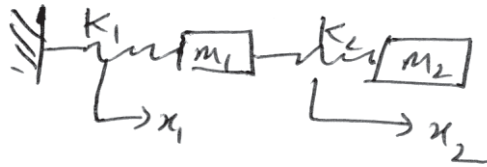

- b) Solve the boundary value problem $U_{tt} = U_{xx}$ with conditions $u(0,t) = u(1,t) = 0$, $u_t(x,0) = 0$ and $u(x,0) = \frac{1}{2}x(1-x)$. Find solution upto $t = 0.4$ by using $h = k = 0.1$ [5]



Total No. of Questions : 7]

SEAT No. :

PA-2610

[Total No. of Pages : 2

[5928]-56

M.E. (Mechanical) (Design Engineering)

MATERIAL SCIENCE AND MECHANICAL BEHAVIOR OF
MATERIALS

(2017 Pattern) (Semester-I) (502202)

Time : 3 Hours]

[Max. Marks : 50

Instructions to the candidates:

- 1) Attempt any five questions.
- 2) Draw neat diagrams wherever necessary.
- 3) Figures to the right indicates full marks.
- 4) Assume suitable data if necessary.
- 5) Use of Scientific Calculator is allowed.

Q1) a) What is fiber reinforced composites? How they are grouped on the basis of diameter and character? Give the examples of each of fiber phase. [5]

b) What is Wiedemann effect and Matteuei effect in Magnetostrictive Smart material? Explain the direct and reverse effect in smart materials. [5]

Q2) In the machine tool, An element is subject to combined bending and twisting. The components of the strain tensor at a given point are $\sigma_x = 72.5\text{MPa}$., $\sigma_y = -12.8\text{MPa}$. $\sigma_z = 0$, $\tau_{xy} = 62.3\text{MPa}$, $\tau_{yz} = 0$, $\tau_{zx} = -45.4\text{MPa}$. where the axis is along the centroidal axis of the beam. Find the values of the principal stresses, the greatest shear stress, and the direction cosines of the largest principal stress. [10]

Q3) a) Explain Bauschinger effect and Bridgman correction. [5]

b) A three-point transverse bending test is conducted on a cylindrical specimen of aluminium oxide having a reported flexural strength of 390 MPa. If the specimen radius is 2.5 mm and the support point separation distance is 30 mm, predict whether or not you would expect the specimen to fracture when a load of 620 N is applied. Justify your prediction. [5]

OR

Q4) a) Explain kinematic hardening and Isotropic hardening Model in Strain Hardening. [5]

b) Explain strain rate and temperature dependence flow stress. [5]

P.T.O.

- Q5)** a) Explain yield Criteria and yield surface for ductile material. [5]
b) Explain elastic-plastic bending and torsion. [5]
- Q6)** a) 'When a shaft is subjected to plastic shear strain caused by torsion, removal of the torque will cause some shear stress to remain in the shaft' Justify. [5]
b) 'If a beam is loaded such that it causes the material to yield, then removal of the load will cause residual stresses. Explain. [5]
- Q7)** In your own words briefly describe the phenomenon of viscoelasticity also explain Maxwell model, Viogt Model and Maxwell-Viogt Model. [10]



[5928]-57

M.E. (Mechanical) (Design Engineering)
ADVANCED STRESS ANALYSIS
(2017 Credit Pattern) (Semester - I) (502203)

Time : 3 Hours]

[Max. Marks : 50

Instructions to the candidates:

- 1) Answer any five questions out of 7.
- 2) All the questions should be solved in one answer book and attach extra supplements if required.
- 3) Neat diagrams must be drawn wherever necessary.
- 4) Use of Calculator is allowed.
- 5) Assume suitable data if necessary, but state the assumptions clearly.

Q1) a) Investigate what problem of Plain stress is solved by the stress function.

$$\phi = \frac{1}{4} S \left(xy - \frac{xy^2}{h} - \frac{xy^3}{h^2} + \frac{Ly^2}{h} + \frac{Ly^3}{h^2} \right)$$

in the region define for $y = 0, y = 2h, x = 0$ on the positive x -axis, as it is the proposed solution for a cantilever problem loaded by a uniform shear S along the lower edge, upper edge and end $x = L$ being free from load.

[6]

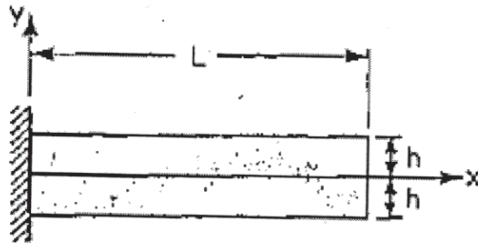

Q1) fig. 1

b) Explain 'Plain stress' with suitable examples. [4]

Q2) a) Evaluate the induced stresses on a rectangular plate of width 'd' and length 'l' by a stress function defined by

case 1 : $\phi = Ax^2$ case 2 : $\phi = C, y^{-2}$.

Comment, which of the above stress function case is valid for the tensile test of a specimen. [5]

P.T.O.

- b) For Beam carrying moving point loads, Obtain condition for maximum bending moment relating the position of load, resultant of point loads and beam length. [5]

Q3) A beam of T-section (flange : 60 mm x 10 mm, web 100 mm x 5 mm) shown in fig. 2, is of 3 m length and simply supported at the ends. It carries a load of 4 kN at centre of span, inclined at 20° to the vertical and passing through centroid of section. If Young's Modulus $E = 200$ GPa, [10]

Determine

- i) Maximum tensile stress,
- ii) Maximum compressive stress
- iii) Deflection due to the load.

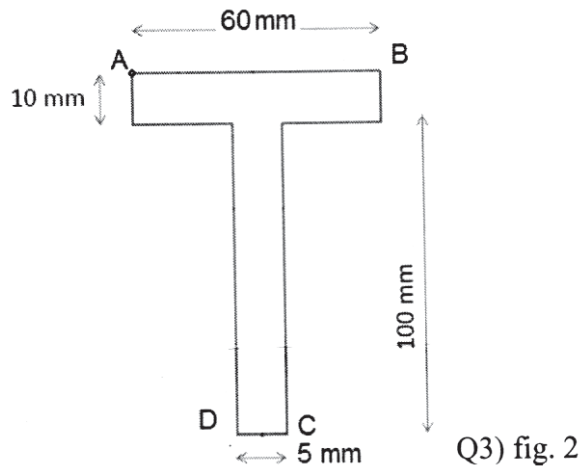

Q4) For an Elliptical Cross-sectional bar subjected to pure torsion, obtain the stress function and relations between shear stress and torque. Also obtain Warping function ψ for the problem. [10]

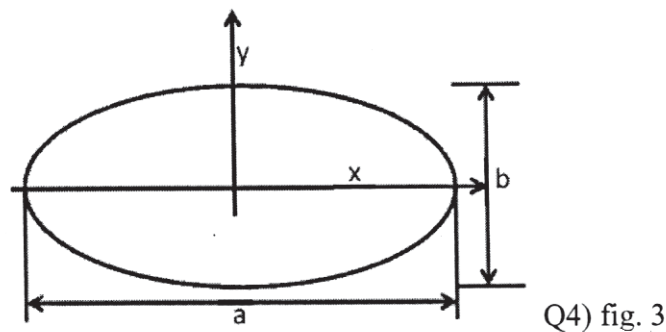

Q5) A steel bearing consisting of an inner race, an outer race, and 12 balls, as shown in figure below. Take $E = 200 \text{ GPa}$, $\nu = 0.29$ and $Y = 1600 \text{ MPa}$. A rated load of $P_0 = 4.2 \text{ kN}$ is given in a manufacturer's handbook for the bearing when operated at 3000 rpm. An Empirical relation is used to determine the load P on the topmost ball that bears the largest portion of the load: $P = 5P_0/n$, in which n is numbers of balls.

At the region of contact between the inner race and topmost ball, determine the maximum principal stress, maximum shear stress, maximum octahedral shear stress, dimension of the area of contact, and distance from the point of contact where these stresses occur. [10]

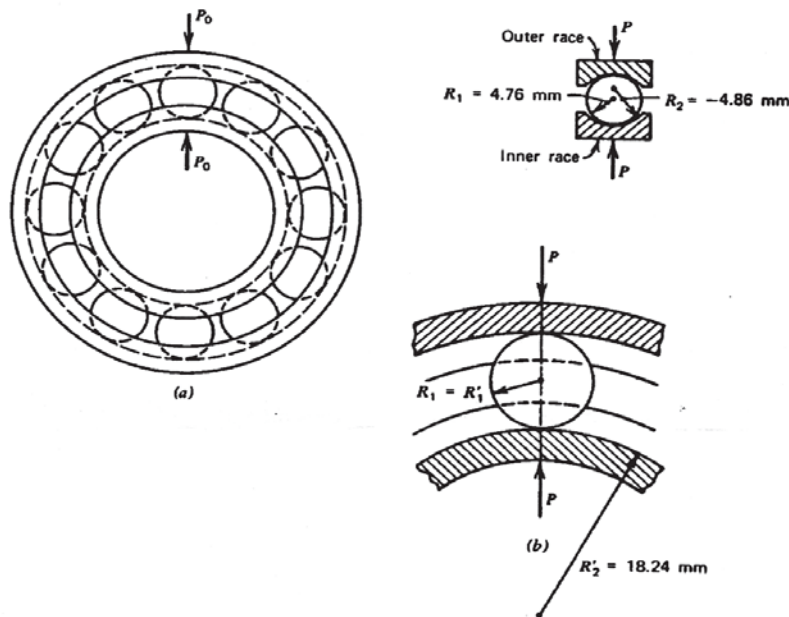

Q5) fig. 4

- Q6)** a) The following state of strain is measured at a point on surface of crane hook's $\epsilon_A = 1000 \mu\text{m/m}$ (at -15° angle), $\epsilon_B = -250 \mu\text{m/m}$ (at 30° angle), $\epsilon_C = 200 \mu\text{m/m}$ (at 75° angle). Evaluate the values and orientation of the principal stresses at the point, Let $E = 200 \text{ GPa}$ and $\nu = 0.285$. [6]
 b) Explain Kelvin's fluid flow analogy, with a suitable example. [4]
- Q7)** a) Explain strain gauge rosette. [5]
 b) Explain the Working of a Plain Polariscope and explain how Iso-clinics and Iso-chromatics are obtained when a stressed model is viewed through a Polariscope. [5]

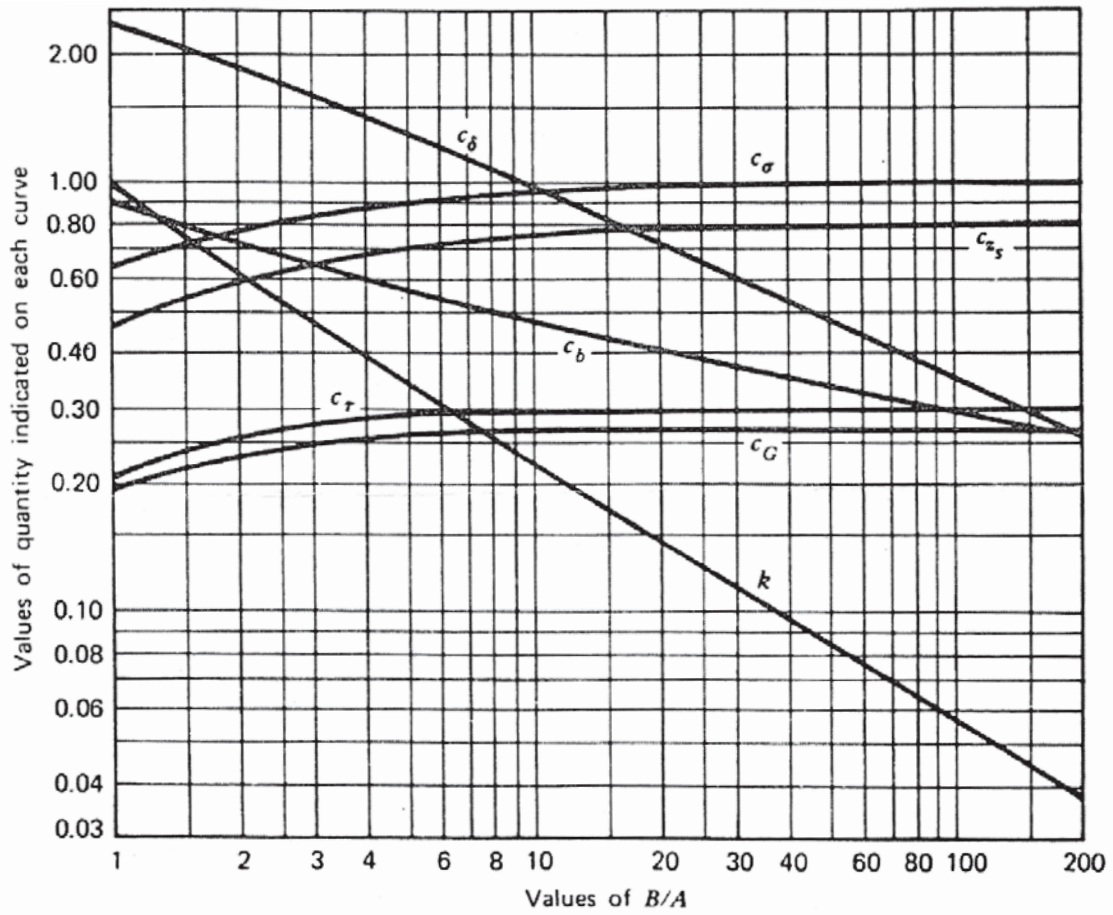

Q5) Fig 5: Stress and Deflection coefficient of two bodies in contact of a point



Total No. of Questions : 8]

SEAT No. :

PA-624

[Total No. of Pages : 2

[5928]-58

M.E. (Mechanical Design Engineering)

RESEARCH METHODOLOGY

Common to all Mechanical Branches

(2017 Credit Pattern) (Semester - I) (502104)

Time : 3 Hours]

[Max. Marks : 50

Instructions to the candidates:

- 1) *Answer any Five questions from the following.*
- 2) *Assume suitable data, if necessary.*
- 3) *Figures to the right indicate full marks.*
- 4) *Use of scientific calculator is allowed.*
- 5) *Use of standard statistical tables having normal distribution, F-test and Chi-square test are permitted.*

Q1) a) Write a note Objectives of Research. [5]

b) Explain procedure for hypothesis testing. [5]

Q2) a) Explain in detail different steps in ‘Research Methodology’ with example?[5]

b) Explain the importance of review of literature, different sources of literature? [5]

Q3) a) How do you estimate mean deviation? How to calculate sum of squares between samples and sum of squares within a sample? [5]

b) Write a note on: (Any two) [5]

i) Qualitative research.

ii) Exploratory research.

iii) Applied research.

Q4) a) How to carry out a linear regression using computer program? What is the significance of R square value? [5]

b) Explain the Meaning of variable and selection of variables. [5]

P.T.O.

- Q5) a)** What is the Role of DSP in data collection in noisy environment? [5]
- b) What is Regression analysis? How you estimate Curve fitting and Developing Correlation. [5]
- Q6) a)** How do you estimate the budget for the proposed project? List steps for one case study. [5]
- b) Explain error analysis and methods to reduce errors in research process.[5]
- Q7) a)** What is the difference in journal publications, conference paper and short communication? [5]
- b) Explain dissemination of research findings and different steps and precautions while writing research report. [5]
- Q8) a)** Write a note on Ethics and check for Plagiarism of the research article.[5]
- b) What do you mean by IPR? What are different categories of IPR in detail? [5]



M.E. (Mechanical) (Design Engineering)
ANALYSIS AND SYNTHESIS OF MECHANISMS
(2017 Pattern) (Semester - II) (502207)

Time : 3 Hours]

[Max. Marks : 50

Instructions to the candidates:

- 1) Answer any five questions.
- 2) Neat diagrams must be drawn wherever necessary.
- 3) Figures to the right indicate full marks.
- 4) Use of a Calculator is allowed.
- 5) Assume suitable data wherever necessary.

Q1) a) The four-bar mechanism shown in figure 1 rotates clock wise at a uniform speed of 100 rad/s. Dimensions of links are:

AB = 100mm, BC = 70mm, CD = 200 mm,

Determine angular velocity and angular acceleration of link BC and CD.

[10]

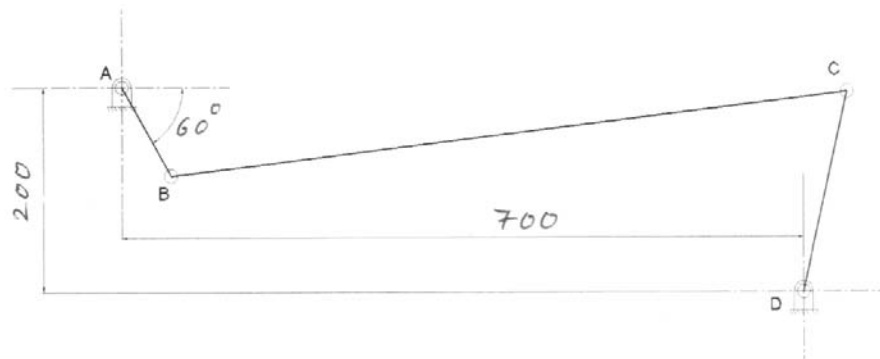

Figure 1

Q2) a) Elaborate on different types of complex mechanisms. [5]

b) Discuss the advantage of using Goodman's method acceleration analysis of a complex mechanism. [5]

Q3) a) Explain the concept of Ball's point and give the application in dwell mechanisms. [5]

b) With neat sketches, explain the concept of fixed and moving centrode. What is the use of obtaining these centrodes? [5]

P.T.O.

Q4) a) Design a four- link mechanism using a graphical method, for the motion of the input and output links, which are governed by a function $y = x^{1.5}$. Where the X varies from 1 to 4. Assume input link angle varies from 30° to 120° and output link angle varies from 60° to 130° . The length of the fixed is 30 mm. Use Chebychev spacing to determine the accuracy points. **[10]**

Q5) a) State and prove the Robert- Chebychev theorem. **[5]**

b) Write a note on the ‘Complex Number Method for Mechanism Synthesis’. **[5]**

Q6) a) Explain in detail Denavit- Hartenberg (D-H) parameters for the analysis of Hooks joint with a neat sketch. **[10]**

Q7) a) Determine the degree of freedom of the mechanism shown in Figure 2. **[5]**

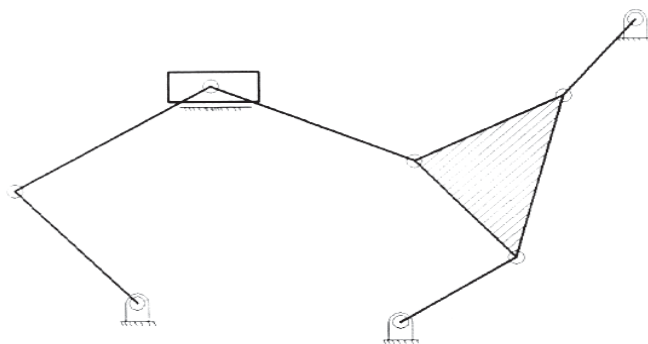

Figure 2

b) Discuss the Transmission and deviation angles of a four- bar mechanism. **[5]**



Total No. of Questions : 8]

SEAT No. :

PA-583

[Total No. of Pages : 2

[5928]-6

M.E. (Civil) (Construction Management)
PROJECT ECONOMICS AND FINANCIAL
MANAGEMENT
(2017 Pattern) (Semester - II) (501028)

Time : 3 Hours]

[Max. Marks : 50

Instructions to the candidates:

- 1) *Attempt Q. 1 or Q. 2, Q. 3 or Q. 4, Q.5 or Q. 6 and Q. 7 or Q. 8.*
- 2) *Neat diagram must be drawn wherever necessary.*
- 3) *Figure to the right indicates full marks.*
- 4) *Assume suitable data, if necessary and clearly state.*
- 5) *Use of cell phone is prohibited in the examination hall.*
- 6) *Use of electronic pocket calculator is allowed.*

- Q1)** a) Discuss in brief about Factors Obstacles to growth of any firm [4]
b) Elaborate the process about managing payments to suppliers and out standings for any construction firm. [5]

OR

- Q2)** a) Discuss in brief about Factors bearing on size of firms. [4]
b) Explain the method about Credit Management for the small construction firm. [5]

- Q3)** a) Explain the procedure of Cost control during design and Construction phase for the over bridge project. [5]
b) Write a short note on over and under capitalization. [4]

OR

- Q4)** a) Develop the Cost implication for small township project with suitable justified example. [5]
b) Write a short note on micro financing. [4]

P.T.O.

- Q5)** a) Explain in detail with suitable example about Budgetary control system. [8]
b) Enlist types of budgets and describe them. [8]

OR

- Q6)** a) Explain procedure for master budgets. [8]
b) Discuss the steps in Budget preparation. [8]

- Q7)** a) Elaborate about the Public policies on ICRA grading of exchange. [8]
b) Describe in detail about SEBI regulations. [8]

OR

- Q8)** a) Justify the requirements of corporate tax planning. [8]
b) Write a note on Indian Venture Capital scenario. [8]



Total No. of Questions : 7]

SEAT No. :

PA-626

[Total No. of Pages : 3

[5928]-60

M.E. (Mechanical - Design Engineering)
ADVANCED MECHANICAL VIBRATIONS
(2017 Pattern) (502208) (Semester - II)

Time : 3 Hours]

[Max. Marks : 50

Instructions to the candidates:

- 1) *Solve any five questions.*
- 2) *Draw Neat diagrams must be drawn wherever necessary.*
- 3) *Use of scientific calculator is allowed.*
- 4) *Assume suitable data wherever necessary.*
- 5) *Figures to the right indicates full marks*

Q1) Determine natural frequency and corresponding mode shape of the system as shown in following fig. by matrix iteration method. **[10]**

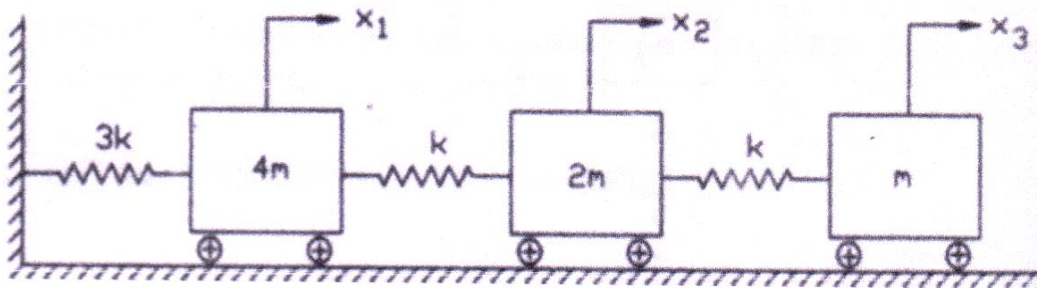

Q2) Derive the frequency equation for lateral vibrations of a cantilever of uniform section having a length l . **[10]**

Q3) Write short note on **[10]**

- a) Free layer and constrained layer damping.
- b) In- situ balancing.
- c) Rayleigh-Ritz method

P.T.O.

Q4) a) A 100 kg turbine operates at 2000 rpm. What percent isolation is achieved if the turbine is mounted on four identical springs in parallel each of stiffness 3×10^5 N/m. [5]

b) Explain narrow band analysis. [5]

Q5) Explain how time domain and frequency domain techniques are used for condition monitoring and fault diagnosis with example in detail. [10]

Q6) a) Explain experimental modal analysis. [5]

b) The spectral density of a random signal is given by [5]

$$S(f) = 0.0001 \text{ m}^2/\text{cycle}/\text{sec} \quad 10 \text{ Hz} \leq f \leq 1000 \text{ Hz}$$
$$= 0 \quad \text{elsewhere}$$

Find the standard deviation and the root mean square value of the signal by assuming its mean value to be 0.05

Q7) Write short notes on

a) Holzer's method. [10]

b) Active vibration control.

c) Duhamel's integral.

Laplace Transform Pairs

S. No.	$f(t)$	$L [f(t)]$
1.	$f(t)$	$\int_0^{\infty} f(t) e^{-st} dt = F(s)$
2.	$x(t) + y(t)$	$X(s) + Y(s)$
3.	$K f(t)$	$K F(s)$
4.	$U(t)$ or 1	$1/s$
5.	$\delta(t)$	1
6.	T	$1/s^2$
7.	t^n	$\frac{n!}{s^{n+1}}$
8.	$\sin \omega t$	$\frac{\omega}{s^2 + \omega^2}$
9.	$\cos \omega t$	$\frac{s}{s^2 + \omega^2}$
10.a	$t e^{-at}$	$\frac{1}{(s+a)^2}$
10.b	$1 - e^{-at}$	$\frac{a}{s(s+a)}$
10.c	$e^{-at} - e^{-bt}$	$\frac{b-a}{(s+a)(s+b)}$
11.	$e^{-at} \sin \omega t$	$\frac{\omega}{(s+a)^2 + \omega^2}$
12.	$e^{-at} \cos \omega t$	$\frac{s+a}{(s+a)^2 + \omega^2}$
13.	$u(t-a)$	e^{-as}/s
14.	$\delta(t-a)$	e^{-as}
15.	$\begin{cases} 0 & \text{when } t < a \\ f(t-a) & \text{when } t > a \end{cases} = f(t-a) u(t-a)$	$e^{-as} F(s)$
16.	$dF(t)/dt$	$s F(s) - f(0)$
17.	$\frac{d^2 f(t)}{dt^2}$	$s^2 F(s) - s f(0) - \frac{df(0)}{dt}$
18.	$\int_0^t f(t) dt$	$\frac{F(s)}{s}$



Total No. of Questions : 7]

SEAT No. :

PA-627

[Total No. of Pages : 2

[5928]-61

M.E. (Mechanical) (Design Engineering)

FINITE ELEMENT METHOD

(2017 Pattern) (Semester-II) (502209)

Time : 3 Hours]

[Max. Marks : 50

Instructions to the candidates:

- 1) *Solve any 5 questions.*
- 2) *Assume suitable data if required.*
- 3) *Draw neat sketches and tables.*

Q1) a) Explain Rayleigh-Ritz method used in FEM. **[5]**

b) Write basic steps in FEM and list 03 prominent limitations of using FEA. **[5]**

Q2) a) Explain boundary condition and its applications. **[4]**

b) A M.S three stepped rod of Diameters 100mm, 80mm & 60mm of $E=2 \times 100000$ N/sq.mm, and Lengths 250mm, 200mm and 150 mm from the first end. One end is fixed and other is subjected to axial tensile load of 2SKN. Model the rod with three stepped rod and solve for following by FEM. **[6]**

- i) Global stiffness matrix
- ii) Nodal displacements
- iii) Reaction forces

Q3) a) A 3-Noded 1-D rod element has displacements and coordinates as shown. **[6]**

Coordinate	1 [40,00]	2 [80,00]	3 [20,00]
Nodal displacement-u	0.01	0.02	0.03

Calculate:

- i) Nodal shape functions
 - ii) Displacement at point P. [70,0]
- b) What is a Tetrahedral Element? When to Use Tetrahedral Elements. **[4]**

PTO.

- Q4)** a) Elaborate Kirchhoff's assumptions of thin plate bending and compute displacement at any point in the plate in the x & y directions. [6]
b) Explain Hexahedral Elements shear locking phenomenon. [4]
- Q5)** a) Explain with example Material Non-Linearity problems and Geometric Non-Linearity problems. [5]
b) Explain Newton Raphson incremental procedure to handle material non-linear problems. [5]
- Q6)** a) Mode superposition of linear structures. [4]
b) Explain h and P numerical convergence method. [6]
- Q7)** a) Explain Pre-processing and Postprocessing in Analysis. [5]
b) Explain different types of symmetries that occurs in meshing. [5]



Total No. of Questions : 7]

SEAT No. :

PA-628

[Total No. of Pages : 2

[5928]-62

M.E. (Mechanical) (Design Engineering)
OPTIMIZATION TECHNIQUES
(2017 Pattern) (Semester - III) (602213)

Time : 3 Hours]

[Max. Marks : 50

Instructions to the candidates:

- 1) *Answer any five questions from the following.*
- 2) *Neat diagrams must be drawn wherever necessary.*
- 3) *Figures to the right indicate full marks.*
- 4) *Use of calculator is allowed.*
- 5) *Assume suitable data, if necessary.*

Q1) How optimization problem can be formed and Discuss classification of optimization problem? **[10]**

Q2) Minimize $f(x) = x^4 - 14x^3 + 60x^2 - 70x$ within the interval $[0,2]$ using golden section method with $n = 4$. **[10]**

Q3) Solve the L.P.P. **[10]**

Maximize $Z = 3x_1 + 2x_2 + 5x_3$;

Subjected to $x_1 + 2x_2 + x_3 \leq 430$

$$3x_1 + 2x_3 \leq 460$$

$$x_1 + 4x_2 \leq 420$$

$$x_1, x_2, x_3 \geq 0$$

Q4) Explain in brief following methods of optimization. (any 2) **[10]**

- a) Simulated Annealing
- b) Genetic Algorithm
- c) Particle Swarm optimization
- d) Fuzzy algorithm

P.T.O.

Q5) Write a short note on **[10]**

- a) Evolutionary structural optimization for displacement or stiffness.
- b) Evolutionary structural optimization based on stress level.

Q6) a) What is topology optimization? Explain with suitable example. **[5]**

b) Write a short note Bi-Directional evolutionary optimization? **[5]**

Q7) Minimize the function

$$f(x) = \frac{1}{2}x^2 - \sin x$$

Newton method with starting point $x_0 = 0.5$ and step size $\Delta x = 0.01$. Use $|(x_{i+1}) - (x_i)| < \epsilon$ for checking convergence. Take $\epsilon = 10^{-5}$. **[10]**



Total No. of Questions : 10]

SEAT No. :

PA-629

[Total No. of Pages : 3

[5928]-63

M.E. (Mechanical) (Design Engineering)
MECHANICAL MEASUREMENTS AND CONTROLS
(2017 Pattern) (Semester - III) (602214)

Time : 3 Hours]

[Max. Marks : 50

Instructions to the candidates:

- 1) Answer Q.1 or Q.2, Q.3 or Q.4, Q.5 or Q.6, Q.7 or Q.8, Q.9 or Q.10.*
- 2) Neat diagrams must be drawn wherever necessary.*
- 3) Figures to the right indicate full marks.*
- 4) Use of electronic scientific pocket calculator is allowed.*
- 5) Assume suitable data, if necessary.*

Q1) a) Define : **[6]**

- i) Mean
- ii) Median
- iii) Standard Deviation
- iv) Variance

b) Differentiate between accuracy and precision. **[4]**

OR

Q2) a) Explain any five static characteristics of instruments. **[5]**

b) Explain load cell used for force measurement. **[5]**

Q3) a) Using a suitable practical example and suitable block diagram, explain the application of a closed loop control system. **[5]**

b) Write a short note on Sampling Theorem. **[5]**

OR

P.T.O.

Q4) a) Explain in details Noise filters and its types. [6]

b) Write a short note on Bitwidth. [4]

Q5) a) A torque T Nm is applied to a shaft having a moment of Inertia J and coefficient of viscous friction of ' μ ' produces an angular shift of ϑ radians. Obtain the transfer function relating ϑ and T . [5]

b) Write a short note on System Stability analysis using Poles and Zeros of System. [5]

OR

Q6) a) A linear system is described by the differential equation $\frac{dy^2}{dt^2} + 3\frac{dy}{dt} + 4y = 2\frac{dy}{dt} + 1$. Find the system poles and zeros of system and locate them on S-plane. [5]

b) Represent a generic state space model using block diagram approach and define the elements of the block diagram. [5]

Q7) a) Explain PI Controller with neat sketch. [4]

b) Fig. 7b shows an error time graph. Sketch the PI controller output with respect to $K_p = 5$, $K_I = 1/s$ and $P_1(D) = 20\%$. [6]

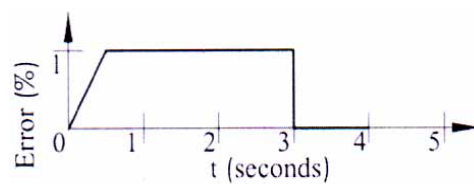

Fig. Q7b

OR

Q8) a) Characteristic equation of the system is given by $s^4 + 3s^3 + 3s^2 + 2s + k = 0$. Find value of k , if system is stable, using Routh Hurwitz criterion. [6]

b) Explain in detail PD Controller. [4]

- Q9)** a) Discuss the importance of controllability in a control system. [4]
- b) Find Analytical expressions for the magnitude and phase responses of $G(s) = \frac{1}{(s+1)(s+3)}$. Also make plots of the log-magnitude and the phase using log-frequency in rad/s as the ordinate. [6]

OR

- Q10)** a) Differentiate between PI and PD Controller. [4]
- b) Explain the steps of sketch the Bode Plot. What are the advantages and limitations of Bode Plots? [6]



Total No. of Questions : 8]

SEAT No. :

PA-630

[Total No. of Pages : 3

[5928]-64

M.E. (Mechanical Heat Power/Energy Engineering)
ADVANCED MATHEMATICS AND NUMERICAL METHODS
(2017 Pattern) (Semester - I) (507101)

Time : 3 Hours]

[Max. Marks : 50

Instructions to the candidates:

- 1) *Answer any five questions.*
- 2) *Neat diagrams must be drawn whenever necessary.*
- 3) *Figures to the right indicate full marks.*
- 4) *Use of electronic pocket calculator is allowed.*
- 5) *Assume suitable data if necessary.*

Q1) a) Using Regula Falsi method find the real root of the equation $x^3 - 2x - 5 = 0$. Correct to two decimal places. **[5]**

b) Fit a straight line to the following data: **[5]**

x	0	1	2	3	4	5	6	7
y	-5	-3	-1	1	3	5	7	9

Q2) a) Find the Lagrange's interpolating polynomial for the data: **[5]**

x	0	1	2	5
y	2	3	12	147

b) Solve the system of the equations by using LU decomposition method: **[5]**

$$2x + 2y + 3z = 4$$

$$4x - 2y + z = 4$$

$$x + 5y + 4z = 3$$

Q3) a) By Cubic spline find $f(1.5)$ for the data: **[5]**

x	1	2	3	4
y	1	2	5	11

b) Use Romberg's method to compute $\int_0^1 \frac{1}{1+x} dx$ correct to three decimal places. **[5]**

P.T.O.

Q4) a) Using power method find the numerically largest eigen value of

$$A = \begin{bmatrix} 25 & 1 & 2 \\ 1 & 3 & 0 \\ 2 & 0 & -4 \end{bmatrix} \quad [5]$$

b) Evaluate $\int_0^{\pi/2} \sin x \, dx$ using Gaussian quadrature 3 point formula. [5]

Q5) a) Using House Holder's method reduce the following matrix A to the tridiazonal form: [5]

$$A = \begin{bmatrix} 1 & 3 & 4 \\ 3 & 2 & -1 \\ 4 & -1 & 1 \end{bmatrix}$$

b) Use Runge-Kutta fourth order method to find $y(0.2)$ with $h = 0.1$ for the initial value problem represented by a mechanical system

$$\frac{dy}{dx} = \sqrt{x+y}, y(0) = 1. \quad [5]$$

Q6) a) Using Adams Bashforth predictor corrector method find y at $x = 0.4$,

given that $\frac{dy}{dx} = x^2 - y$, $y(0) = 1$, $y(0.1) = 0.905125$, $y(0.2) = 0.8212352$,
 $y(0.3) = 0.7491509$. [5]

b) Use Gauss seidel method to solve the partial differential equation

$$\frac{\partial^2 u}{\partial x^2} + \frac{\partial^2 u}{\partial y^2} = 0 \text{ represented by mechanical system carry out five iterations.}$$

Given that: [5]

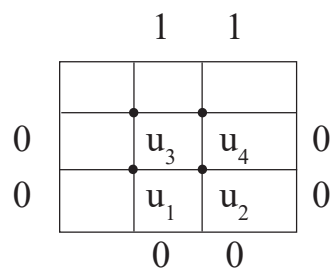

Q7) a) Solve the heat equation $\frac{\partial u}{\partial t} = \frac{\partial^2 u}{\partial x^2}$ for the following conditions: At $t = 0$, $u(x, 0) = 0$ where $0 \leq x \leq 1$ and $u(0, t) = u(1, t) = t$ where $0 \leq t \leq \frac{1}{8}$. Assume step in x as $\frac{1}{4}$ and step in t as $\frac{1}{8}$. [5]

b) Solve the following simultaneous equations by Gauss-Seidel Method. [5]

$$-x + y + 4z = 3$$

$$5x - y + z = 10$$

$$2x + 8y - z = 11$$

Q8) a) Use Heun's method to solve the initial value problem: [5]

$$y'(x) = \frac{x-y}{2}, y(0) = 1 \text{ over } [0,1] \text{ using step size of } 0.5.$$

b) Solve $\frac{\partial^2 u}{\partial t^2} = 16 \frac{\partial^2 u}{\partial x^2}$, $0 \leq x \leq 5$, $0 \leq t \leq 1.25$ for the following conditions: [5]

$$\text{At } u(0, t) = u(5, t) = 0, t > 0$$

$$u(x, 0) = x^2(5-x) \text{ and } \left. \frac{\partial u}{\partial t} \right|_{(x,0)} = 0 \text{ for } 0 \leq x \leq 5. \text{ Assume step in } x \text{ as } 1$$

and step in t as 0.25.



Total No. of Questions : 7]

SEAT No. :

PA-631

[Total No. of Pages : 2

[5928]-65

M.E. (Mechanical) (Heat Power Engineering)
ADVANCED THERMODYNAMICS AND COMBUSTION
TECHNOLOGY
(2017 Pattern) (Semester - I) (502102)

Time : 3 Hours]

[Max. Marks : 50

Instructions to the candidates:

- 1) *Solve any five questions.*
- 2) *Neat diagrams must be drawn whenever necessary.*
- 3) *Figures to the right side indicate full marks.*
- 4) *Use of steam tables, Mollier charts, scientific calculator is allowed.*
- 5) *Assume suitable data if necessary.*

Q1) a) Define compressibility factor and explain the term reduced pressure and reduced temperature. **[5]**

b) A piston cylinder device contain 0.1 m^3 of liquid water and 0.9 m^3 of water vapour in equilibrium at 800 kpa. Heat is transferred at constant pressure until the temperature reaches 350°C . **[5]**

- i) What is the initial temperature of the water?
- ii) Determine the total mass of the water.
- iii) Calculate the final volume.

Q2) a) Explain the term critical pressure, critical temperature and triple point of water. **[4]**

b) One kg of ice at -10°C is allowed to melt in atmosphere maintained at 30°C . The ice and the water so formed rises in temperature to that of atmosphere Determine: **[6]**

- i) Entropy change of system considering ice as system.
- ii) Entropy change of surrounding considering atmosphere as surrounding.
- iii) Entropy change of universe.

C_p of ice = 2 kJ/kgk and latent heat of fusion of ice = 335 kJ/kg .

P.T.O.

- Q3)** a) State and explain Third Thermodynamics. [3]
 b) Explain the term Dead State. [3]
 c) What is second law efficiency. [4]

- Q4)** a) Derive the first and second Tds equations. [5]
 b) Derive the Clapeyron equation. [5]

- Q5)** a) What is adiabatic flame temperature. [4]
 b) Acetylene gas (C_2H_2) is burned completely with 20 percent excess air during a steady flow combustion process the fuel and air enter the combustion chamber at $25^\circ C$ and the products have at 1500 K. Determine: [6]
 i) The air fuel ratio and
 ii) The heat transfer for this process. Take

Substance	h_{of} kJ/kmol	h_{298K} kJ/kmol	h_{1500K}^- kJ/kmol
C_2H_2	226730	-	-
O_2	0	8682	49292
N_2	0	8669	47073
$H_2O(g)$	-241820	9904	57,999
CO_2	-393520	9364	71078

- Q6)** a) Explain inversion curve and Joule-Thomson coefficient. [6]
 b) Discuss Amagat's law. [4]

- Q7)** Write short notes on (any two): [10]
 a) Thermodynamics of Aging and Death.
 b) Thermodynamics of Biological cells.
 c) Fugacity and activity.
 d) Mole and mass fraction.



Total No. of Questions : 7]

SEAT No. :

PA-632

[Total No. of Pages : 2

[5928]-66

M.E. (Mechanical - Heat Power Engineering)

ADVANCED FLUID MECHANICS

(2017 Pattern) (Semester - I) (502103)

Time : 3 Hours]

[Max. Marks : 50

Instructions to the candidates:

- 1) Answer any five questions.
- 2) Neat diagrams must be drawn wherever necessary.
- 3) Figures to the right indicate full marks.
- 4) Use of scientific calculator is allowed.
- 5) Assume suitable data if necessary.

Q1) a) Explain the Lagrangian and Eulerian descriptions. [6]

b) A steady, incompressible, two-dimensional velocity field is given by the following components in the xy-plane: [4]

$$u = 0.20 + 1.3x + 0.85y, v = -0.50 + 0.95x - 1.3y$$

Calculate the acceleration field (find expressions for acceleration components a_x and a_y) and calculate the acceleration at the point $(x, y) = (1, 2)$.

Q2) Derive generalized expression of Navier-stokes equations. [10]

Q3) a) During a high Reynolds number experiment, the total drag force acting on a spherical body of diameter $D = 12$ cm subjected to airflow at 1 atm and 5°C is measured to be 5.2 N. The pressure drag acting on the body is calculated by integrating the pressure distribution (measured by the use of pressure sensors throughout the surface) to be 4.9 N. Determine the friction drag coefficient of the sphere. The density and kinematic viscosity of air at 1 atm and 5°C are $\rho = 1.269$ kg/m³ and $\nu = 1.382 \times 10^{-5}$ m²/s. The drag coefficient of sphere in turbulent flow is $C_D = 0.2$. [5]

b) Explain the concept of Superposition of Plane-Flow Solutions for irrotational vortex. [5]

P.T.O.

- Q4) a)** Explain adiabatic duct flow with friction and derive expression for fanno line. [5]
- b) Carbon dioxide enters an adiabatic nozzle at 1200 K with a velocity of 50 m/s and leaves at 400 K. Assuming constant specific heats at room temperature, determine the Mach number (i) at the inlet and (ii) at the exit of the nozzle. The gas constant of carbon dioxide is $R = 0.1889 \text{ kJ/kg} \cdot \text{K}$. Its constant pressure specific heat and specific heat ratio at room temperature are $c_p = 0.8439 \text{ kJ/kg} \cdot \text{K}$ and $k = 1.288$. [5]
- Q5) a)** Explain the development of the velocity boundary layer in a pipe with diagram. [5]
- b) A wind tunnel has a test section that is 40 cm in diameter and 60 cm in length. The air is at 20°C. At a uniform air speed of 2.0 m/s at the test section inlet, by how much will the centerline air speed accelerate by the end of the test section? The kinematic viscosity of air at 20°C is $\nu = 1.516 \times 10^{-5} \text{ m}^2/\text{s}$. [5]
- Q6) a)** Explain the significance of Turbulence modeling. Write equations for $k - \epsilon$ model. [6]
- b) Determine the thickness of boundary layer at the trailing edge of smooth plate of length 4 m and of width 1.5 m, when the plate is moving with a velocity of 4 m/s in stationary air. Take kinematic viscosity of air as $1.5 \times 10^{-5} \text{ m}^2/\text{s}$. [4]
- Q7) a)** Illustrate Creeping flow past a sphere. [4]
- b) Write short note on: [6]
- i) Irrotational vortex.
 - ii) Vortex flow.
 - iii) Doublet.



Total No. of Questions : 7]

SEAT No. :

PA-633

[Total No. of Pages : 5

[5928]-68

M.E. (Mechanical) (Heat Power Engineering)

ADVANCED HEAT TRANSFER

(2017 Pattern) (Semester - II) (502107)

Time : 3 Hours]

[Max. Marks : 50

Instructions to the candidates:

- 1) Attempt Any Five Questions.
- 2) Neat diagrams must be drawn wherever necessary.
- 3) Figures to the right of each question indicate full marks.
- 4) Assume suitable data, wherever necessary and mention the same clearly.
- 5) Use of steam tables, Mollier chart and calculator is allowed.

Q1) a) Consider 50 mm diameter spherical hot object initially at uniform temperature of 225 °C suddenly exposed to an ambient of 25°C with heat transfer coefficient of 500 W/m²-°C. Take density of object 7850 kg/m³, thermal conductivity = 60 W/m-°C and specific heat 460 J/kg-k. Determine [5]

- i) Center temperature 2 min after start of cooling process.
- ii) Temperature at a depth 1 cm after start of cooling process.
- iii) Energy removed from the sphere during this time.

b) What do you mean by Newtonian Heating and cooling? What is I.T.G? How is developed in Object? [5]

Q2) a) Consider the base plate of a 1200-W iron that has a thickness of L=0.5 cm, base area of A = 300 cm², and thermal conductivity of k = 15 W/m. °C. The inner surface of the base plate is subjected to uniform heatflux generated by the resistance heaters inside, and the outer surface loses heat to the surroundings at T = 20°C by convection. Taking the convection heat transfer coefficient to be h = 80 W/m². °C and neglecting heat loss by radiation, obtain an expression for the variation of temperature in the base plate, and evaluate the temperatures at the inner and the outer surfaces. [5]

b) What do you mean by Thermal Contact Resistance? What are methods to reduce the same? [5]

P.T.O.

- Q3) a)** Experimental results for the local heat transfer coefficient h_x for flow over a flat plate with an extremely rough surface were found to fit the relation

$$h_x(x) = x^{-0.1}$$

Where $x(m)$ is the distance from the leading edge of the plate. Develop an expression for the ratio of the average heat transfer coefficient for a plate of length x to the local heat transfer coefficient h_x at x . [5]

- b) Consider laminar flow of a fluid over a flat plate maintained at a constant temperature. Now the free-stream velocity of the fluid is doubled. Determine the change in the drag force on the plate and rate of heat transfer between the fluid and the plate. Assume the flow to remain laminar. [5]

- Q4) a)** Explain physical significance of following dimensionless numbers [5]

- i) Peclet Number
- ii) Stanton Number
- iii) Rayleigh Number

- b) Water enters a tube with fully developed velocity and uniform temperature of 20°C. The inside diameter of the tube is 4 cm and its length is 9 m. It is desired to heat the water to 60°C by maintaining the surface at 90°C uniform temperature. Determine the mass flow rate to satisfy the above condition. Take

$$k = 0.64 \text{ W/m}^\circ\text{C}, \nu = 0.62 \times 10^{-6} \text{ m}^2/\text{s}, \rho = 995 \text{ Kg/m}^3, C_p = 4187 \text{ KJ/kg}^\circ\text{C}, \beta = 4.25 \times 10^{-4} \text{ per degree Kelvin}$$

Use following correlations

$$\text{Nu} = 0.023 \text{ Re}_d^{0.8} \text{Pr}^{0.4}. \quad [5]$$

- Q5) a)** Explain following terms of mixed convection with neat sketch [5]

- i) Assisting flow
- ii) Opposing flow
- iii) Transverse flow

- b) A plate type 200 mm × 300 mm heater is immersed in water bath at 40°C. The larger side of heater is maintained vertical. The heater rating is 3.5 kW. Determine the steady state temperature attended by the heater using following thermo physical properties. Consider heat transfer from one side of the plate

$$k = 0.667 \text{ W/m } ^\circ\text{C}, \nu = 0.415 \times 10^{-6} \text{ m}^2/\text{s}, \rho = 977.8 \text{ kg/m}^3 C_p = 4187 \text{ KJ/kg } ^\circ\text{C}, \beta = 4.15 \times 10^{-4} \text{ per degree Kelvin}$$

For heat transfer by convection use following correlation

$$\text{Nu} = 0.13 (\text{Ra})^{(0.33)}. \quad [5]$$

- Q6) a)** Explain with neat sketch different flow regimes encountered in flow boiling in a tube under forced convection [5]

- b) The steam at 165°C condenses in the shell side of a heat exchanger over the tubes through which water flows. Water enters the 4-cm-diameter, 14-m-long tubes at 20°C at a rate of 0.8 kg/s. Determine the exit temperature of water and the rate of condensation of steam. Take fluid properties at 85°C and latent heat of steam as 2066.5 kJ/kg.

Use following correlations

$$\text{Nu} = 4.6 \text{ for laminar flow, Constant heat flux}$$

$$\text{Nu} = 3.66 \text{ for laminar flow, Constant wall temperature}$$

$$\text{Nu} = 0.023 \text{ Re}_d^{(0.8)} \text{Pr}^{(0.4)} \text{ for turbulent flow, Constant heat flux or wall temp}$$

[5]

- Q7) a)** What is the radiation effect? How does it influence the temperature measurements? [5]

- b) What is a gray body? How does it differ from a blackbody? What is a diffuse gray surface? [5]

Figure 1: Physical Properties of Air (1 atm)

t °C	ρ kg/m ³	c_p kJ/kgK	$k \times 10^2$ W/mK	$\alpha \times 10^4$ m ² /hr	$\mu \times 10^2$ kg/hr-m	$\nu \times 10^6$ m ² /s	Pr –
10	1.247	1.005	2.511	7.22	6.346	14.16	0.705
20	1.205	1.005	2.592	7.71	6.533	15.06	0.703
30	1.165	1.005	2.673	8.23	6.717	16.00	0.701
40	1.128	1.005	2.755	8.75	6.904	16.96	0.699
50	1.093	1.005	2.824	9.29	7.067	17.95	0.698
60	1.060	1.005	2.894	9.79	7.221	18.97	0.696
70	1.029	1.009	3.045	10.28	7.523	21.09	0.692
80	1.000	1.009	3.045	10.87	7.523	21.09	0.692
90	0.972	1.009	3.127	11.48	7.701	22.10	0.690
100	0.946	1.009	3.208	12.11	7.880	23.13	0.688
120	0.898	1.009	3.336	13.26	8.170	25.45	0.686
140	0.854	1.013	3.487	14.52	8.479	27.80	0.684
160	0.815	1.017	3.638	15.80	8.786	30.08	0.682
180	0.779	1.022	3.778	17.10	9.070	32.49	0.681
200	0.746	1.026	3.929	18.49	9.380	34.85	0.680

Figure 2: Physical Properties of Water (Liquid state)

t °C	ρ kg/m ³	c_p kJ/kgK	$k \times 10^2$ W/mK	$\alpha \times 10^4$ m ² /hr	$\mu \times 10^2$ kg/hr-m	$\nu \times 10^6$ m ² /s	Pr –
0	999.9	4.212	55.093	4.71	644.093	1.789	13.67
10	999.7	4.191	57.418	4.94	469.818	1.306	9.54
20	998.2	4.183	59.859	5.16	361.892	1.006	7.02
30	995.7	4.174	61.718	5.35	288.668	0.805	5.42
40	992.2	4.174	63.345	5.51	235.602	0.659	4.31
50	988.1	4.178	64.740	5.65	197.771	0.556	3.54
60	983.2	4.178	65.902	5.78	169.305	0.478	2.98
70	977.8	4.187	66.716	5.87	146.370	0.415	2.55
80	971.8	4.195	67.413	5.96	127.924	0.365	2.21
90	965.3	4.208	67.995	6.03	113.507	0.326	1.95
100	958.4	4.220	68.227	6.09	101.910	0.295	1.75

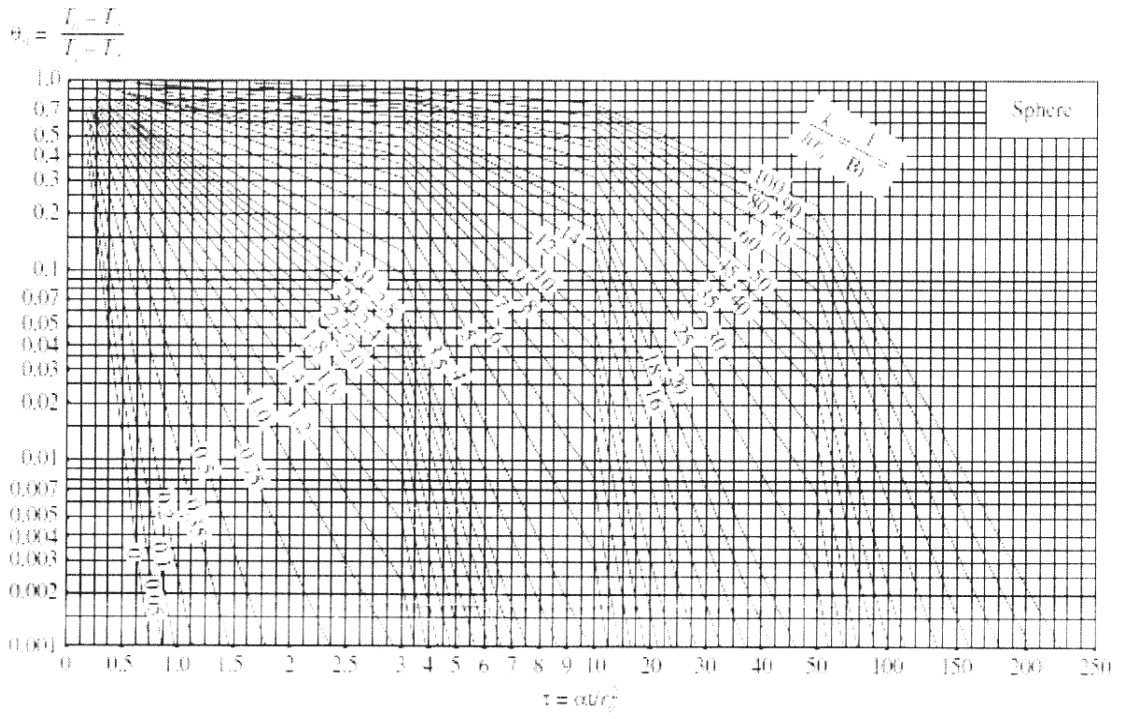

(a) Midspan temperature (from M. P. Heisler)

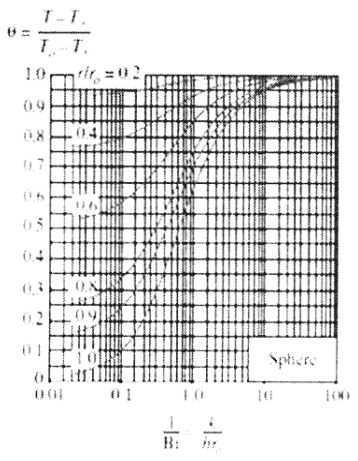
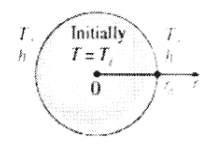

(b) Temperature distribution (from M. P. Heisler)

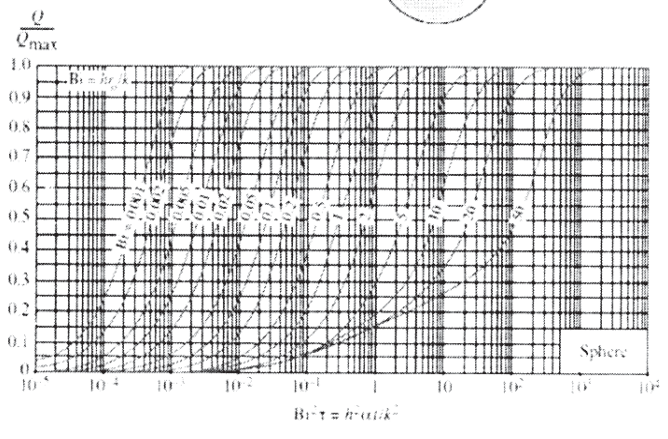

(c) Heat transfer (from H. Grober et al.)

Transient temperature and heat transfer charts for a sphere of radius r_o , initially at a uniform temperature T_i subjected to convection from all sides to an environment at temperature T_∞ with a convection coefficient of h .

Figure 3 Heisler Grober Chart for Sphere



Total No. of Questions : 7]

SEAT No. :

PA-634

[Total No. of Pages : 2

[5928]-69

M.E. (Mechanical) (Heat Power Engg.)
AIR CONDITIONING TECHNOLOGY
(2017 Pattern) (Semester - II) (502108)

Time : 3 Hours]

[Max. Marks : 50

Instructions to the candidates :

- 1) *Answer any 5 questions out of 7.*
- 2) *Draw neat labelled diagrams wherever necessary.*
- 3) *Assume suitable data if necessary and mention it clearly.*
- 4) *Use of steam table, p-h chart, Psychrometric chart and scientific calculator is allowed.*
- 5) *Figures to the right side indicates full marks.*

Q1) a) Explain the significance of Dry bulb temperature, Relative humidity, ADP and Air washer. **[4]**

b) What is Air refrigeration system? Explain with neat sketch of Vapor Compression Cycle. **[6]**

Q2) a) Explain the local and central Air Conditioning system. **[4]**

b) 30 m³/min of stream of moist air at 15°C DBT and 13°C WBT are mixed with 12 m³/min of a second stream at 25°C DBT and 18°C WBT. Barometric pressure is one standard atmosphere. Determine the dry bulb and wet bulb temperature of the resulting mixture. **[6]**

Q3) 100 m³/min outdoor air at 43.3°C DBT and 37% relative humidity is mixed with 200 m³/min of air at 38.2°C DBT and 24.5°C WBT. The mixed air is dehumidified first by a cooling coil having bypass factor of 0.32 and apparatus dew point of 15°C and then by a chemical dehumidifier at 30°C dry bulb temperature. Air is then passed over a cooling coil whose surface temperature is 15°C and bypass factor 0.26. calculate: **[10]**

- a) Capacity of two cooling coils in tons of refrigeration.
- b) Capacity of coil dehumidifier in kg/min.
- c) Capacity of chemical dehumidifier in kg/min.
- d) Total dehumidifying capacity of the system in kg/min.

P.T.O.

Q4) The following data relates to the office air conditioning plant having maximum seating capacity of 25 persons :

Outside design condition	= 34°C DBT, 28°C WBT
Inside design conditions	= 24°C DBT, 50% RH
Solar heat gain	= 9000 W
Latent heat gain per person	= 100 W
Sensible heat gain per person	= 95 W
Lighting Load	= 2300 W
Sensible heat load from other sources	= 11600 W
Infiltration load	= 15 m ³ /min

Assure 40% fresh air and 60% of recalculated air passing through the evaporator coil and the by-pass factor of 0.15, find the dew point temperature of the coil and the capacity of the plant. **[10]**

Q5) a) Describe the procedure for the Duct design. **[4]**

b) With the help of example, explain equal friction method of Duct design. **[6]**

Q6) a) Write down the difference between water cooled VRV and air cooled VRV. **[4]**

b) Short note on : **[6]**

i) Desiccant Dehumidification.

ii) Types of ventilation system.

Q7) a) Explain the significance of chiller ceiling and chiller beams. **[4]**

b) Explain the open loop and close loop control system for air conditioning system. **[6]**



Total No. of Questions :8]

SEAT No. :

PA-584

[Total No. of Pages : 3

[5928]-7

M.E. (Civil-Construction & Management)
OPERATIONS RESEARCH
(2017 Credit Pattern) (Semester-II) (501029)

Time : 3 Hours]

[Max. Marks : 50

Instructions to the candidates:

- 1) *Answer Q.1 or Q.2, Q.3 or Q.4, Q.5 or Q.6 and Q.7 or Q.8.*
- 2) *Neat diagrams must be drawn wherever necessary.*
- 3) *Figures to the right indicate full marks.*
- 4) *Assume suitable data, if necessary and clearly state.*
- 5) *Use of cell phone is prohibited in the examination hall.*
- 6) *Use of electronic pocket calculator is allowed.*

Q1) a) Discuss the scope and limitations of Operations Research. **[4]**

b) Give the values of x so that the following function is a concave function **[5]**

i) $F(x) = 6x^3 - 6x^2 - 6$

ii) $F(x) = 2x^4 - x^2$

OR

Q2) a) A company sells two different products A and B making a profit of Rs. 40 and Rs. 30 respectively. They are produced by a common production process and are sold in two different markets. The production process has a capacity of 30,000 man-hours. It takes 3 hours to produce a unit of A and 1 hour to produce a unit of B. The maximum number of units of A and B that can be sold in the market are 8,000 and 12,000 respectively. Formulate the linear programming problem. **[4]**

b) What is meant by Sensitivity Analysis? Discuss various changes in the parameters of a Linear Programming method that can be studied under this. **[5]**

P.T.O.

- Q3) a)** Determine optimum solution by using VAM for following transportation problem. [5]

		Destination					Supply
		1	2	3	4	5	
Origin	A	12	31	14	11	14	4
	B	19	17	17	13	18	8
	C	10	11	12	19	12	9
Demand		3	3	4	5	6	

- b) Discuss the multistage decision process adopted for optimization of problems. Also, elaborate its applications in Construction Industry. [4]

OR

- Q4) a)** Solve the following assignment problem to minimize the cost [5]

	1	2	3	4
A	21	21	17	12
B	22	22	18	13
C	28	27	24	18
D	19	18	25	13

- b) Describe the method of optimization using Golden section method. Use suitable example. [4]

- Q5) a)** Differentiate between constrained and unconstrained problem with the help of suitable examples. [8]

- b) Solve the following NLP with Lagrangian Multiplier technique. [8]

$$\text{Maximize } Z = 2x_1^2 - 7x_2^2 + 12x_1x_2$$

Subject to

$$2x_1 + 5x_2 = 98$$

$$x_1, x_2 \geq 0$$

OR

- Q6) a)** Solve the following two variables unconstrained nonlinear problem using gradient search method for two iterations with initial trial solution (0,0)

$$\text{Maximize } f(x) = 8x_1 - x_1^2 - 12x_2 - 2x_2^2 + 2x_1x_2 \quad [8]$$

- b) Explain the steps to be followed to solve an NLP using Newtons Method. [8]

- Q7) a) Interarrival and service time in a waiting line problem have the following frequency distribution based on 100 such iterations. [8]

Interarrival time (min)	3	6	9	12	15	18
Frequency	6	9	24	38	16	7

Random numbers: 9, 11, 90, 64, 37, 29, 43, 78, 87, 56

Service time (min)	4	6	8	10	12
Frequency	4	10	20	42	24

Random numbers: 15, 19, 61, 49, 54, 73, 85, 96, 31, 22

Calculate average waiting time and average idle time.

- b) Explain clearly the following terms [8]
- Strategy
 - Payoff matrix
 - Saddle point
 - Players

OR

- Q8) a) A firm is considering replacement of machine, whose purchase cost is Rs. 10,000. The running (maintenance and operating) costs are found from experience to be as follows: [8]

Year	1	2	3	4	5	6	7
Operating cost (Rs.)	1500	1900	2300	2900	3600	4500	5500
Resale value (Rs.)	5000	2500	1250	600	400	400	400

When should the machine to be replaced?

- b) Auto vehicles arrive at a petrol pump having one petrol unit, in Poisson's fashion with an average of 10 units per hour. The service time is distributed exponentially with a mean of 3 minutes. Find the following: [8]
- average number of units in the system
 - average waiting time for the customers
 - average length of queue
 - utilization factor for the petrol pump



Total No. of Questions : 8]

SEAT No. :

PA-635

[Total No. of Pages : 2

[5928]-70

M.E. (Mechanical) (Heat Power Engineering)

MEASUREMENTS AND CONTROLS

(2017 Pattern) (Semester-II) (502109)

Time : 3 Hours]

[Max. Marks : 50

Instructions to the candidates:

- 1) *Solve any 5 questions.*
- 2) *Neat diagrams must be drawn wherever necessary.*
- 3) *Figures to the right indicate full marks.*
- 4) *Use of logarithmic tables, slide rule, mollier charts, electronic pocket calculator and steam tables is allowed.*
- 5) *Assume suitable data, if necessary.*

Q1) a) Explain the varieties of drifts of input-output relations with schematics. [5]
b) Differentiate between deflection and null type of instruments with suitable examples. [5]

Q2) a) Enumerate the types of errors in measurements. Explain standard and probable error. [6]
b) Explain Allen salt velocity method and ultrasonic flow meter. [4]

Q3) a) Explain the measures taken to minimize the systematic errors. [5]
b) Explain with neat sketch the working of hot wire anemometer. [5]

Q4) a) Explain the following terms: [4]
i) Static error
ii) Dynamic error
iii) Probable error
iv) Mean Standard Deviation.

P.T.O.

b) Calculate correlation coefficient from following data: [6]

$N=10, \sum X=350, \sum Y=310, \sum (X-35)^2 = 162, \sum (Y-31)^2 = 222, \sum (X-35)(Y-31) = 92.$
Also find regression line Y on X.

Q5) a) Differentiate between systematic and random errors. Also explain the sources of these errors. [4]

b) Find of correlation between marks given by X and Y as given below:[6]

X	52	53	42	60	45	41	37	38	25	27
Y	65	68	43	38	77	48	35	30	25	50

Q6) a) Explain the construction and working of turbine flow meter. [5]

b) What are the method of measuring humidity and liquid level? [5]

Q7) a) How do you measure frequency and phase angle. [4]

b) Explain construction and working of the torque measurement devices. [6]

Q8) a) Explain the working of PI hydraulic controller. [5]

b) Explain in detail working of electronic proportional controller. [5]



Total No. of Questions : 7]

SEAT No. :

PA-4012

[Total No. of Pages : 2

[5928]-71

M.E Mechanical (Heat Power Engineering)

COMPUTATIONAL FLUID DYNAMICS

(2017 Pattern) (Semester - III) (602113)

Time : 3 Hours]

[Max. Marks : 50

Instructions to the candidates:

- 1) *Answer any five questions*
- 2) *Neat diagrams must be drawn wherever necessary.*
- 3) *Figures to the right indicate full marks.*
- 4) *Use of electronic pocket calculator is allowed.*
- 5) *Assume Suitable data jf necessary.*

Q1) a) Explain the mathematical nature of parabolic equation and their physical boundary conditions. [4]

b) Explain the Transport equation in differential form and explain the significance of each term. [6]

Q2) a) Describe the physical meaning of Substantial and Local Derivative. [4]

b) Explain the difference between explicit and implicit methods with its significant. [6]

Q3) a) Explain QUICK Convection Scheme. [4]

b) Explain Solution of two dimensional steady heat conduction equation using explicit approach. [6]

Q4) a) Write two dimensional heat convection-diffusion equation and discretize it with finite volume method. [7]

b) Write the difference between FEM and FVM. [3]

P.T.O.

- Q5)** a) Derive the Navier-Stoke's equation for incompressible flow. [4]
b) Explain the significance of 1 -D transient convection-diffusion system.[6]
- Q6)** a) Explain use of SIMPLE algorithm for solution of 2-D Navier Stokes equations. [6]
b) Importance of Pressure correction method in SIMPLE algorithm. [4]
- Q7)** a) Explain the necessity of turbulence modeling in CFD. Explain Reynolds average Navier stoke (RANS) in details. [5]
b) Explain the (i) $k-\varepsilon$ turbulence model and (ii) $k-\omega$ turbulence model. [5]



Total No. of Questions : 7]

SEAT No. :

PA-636

[Total No. of Pages : 3

[5928]-72

M.E. (Mechanical) (Heat Power Engineering)
DESIGN OF HEAT TRANSFER EQUIPMENTS
(2017 Pattern) (Semester - III) (602114)

Time : 3 Hours]

[Max. Marks : 50

Instructions to the candidates:

- 1) *Answer any five questions.*
- 2) *Neat diagrams must be drawn wherever necessary.*
- 3) *Figures to the right indicates full marks.*
- 4) *Use of calculator, steam tables is allowed.*
- 5) *Assume suitable data, if necessary.*

Q1) a) Classify heat exchanger according to construction type and explain the characteristics of each type. [4]

b) Consider a shell and tube heat exchanger constructed from a 0.0254m OD tube to cool 6.93 kg/s of a 95% ethyl alcohol solution ($C_p = 3810$ J/kgk) from 66°C to 42°C using water available at 10°C ($C_p = 4187$ J/kgk) at a flow rate of 6.30 kg/s. In the heat exchanger 72 tubes will be used. Assume that the overall coefficient of heat transfer based on the outer tube area is 568 W/m²k. Calculate the surface area and the length of the heat exchanger for each of the following arrangements. [6]

- i) Parallel flow shell and tube heat exchanger
- ii) Counter flow shell and tube heat exchanger

Q2) a) Explain chain rule Methodology for heat exchanger effectiveness. [4]

b) Hot oil is to be cooled by water in a 1-Shell Pass and 8 tube passes heat exchanger. The tubes are thin walled and are made of copper with an internal diameter of 1.4cm. The length of each tube pass in heat exchanger is 5m and the overall heat transfer coefficient is 310 N/m²°C. Water flows through the tubes at a rate of 0.2 kg/s and the oil through the shell at a rate of 0.3 kg/s. The water and oil enter at temperature of 20°C and 150°C respectively. Determine the rate of heat transfer in the heat exchanger and the outlet temperature of the water and the oil. (Take $\epsilon = 0.47$) [6]

P.T.O.

Q3) A shell and tube heat exchanger is designed to cool the shell side lubricating oil from 65°C to 60°C following are the specifications for the shell and tube heat exchanger. **[10]**

Tube outside diameter = 19 mm

Tube wall thickness = 1.2 mm

Tube pitch = 25 mm square layout

Number of baffles = 14

Cross flow area near the shell centerline - 0.04429 m²

Number of effective tube rows crossed in one window zone = 3.868

Flow area through the window zone = 0.0126/m²

Oil flow rate = 36.3 kg/s

Ideal tube bank friction factor = 0.23

Number of effective tube rows baffle section = 9

Shell side Reynolds number = 242

Oil density = 849 kg/m³

Factors for various leakage and bypass flows for the pressure drop correction are

- a) 0.59 for baffle to shell and tube to baffle leakage stream
- b) 0.69 for baffle to shell bypass stream and
- c) 0.81 for unequal baffle spacing on inlet and exit baffle sections.

Calculate shell side pressure drop

- Q4)**
- a) What are various experimental techniques for determining surface characteristics. Explain any one. **[5]**
 - b) Explain the major operating parameters that has to be considered while selecting heat exchanger. **[5]**

- Q5)** a) What are the various materials used for the construction of cooling towers. Explain in detail. [5]
- b) Explain the various factors affecting the performance of cooling towers. [5]
- Q6)** a) What is the role of insulation in the design of furnace? Explain any four insulations. [5]
- b) What are the different parameters considered for furnaces design. [5]
- Q7)** a) Explain the concept of heat pipe with neat sketch. [5]
- b) Write a note on heat transfer augmentation techniques. [5]



Total No. of Questions : 8]

SEAT No. :

PA-637

[Total No. of Pages : 2

[5928]-75

M.E. (Artificial Intelligence and Data Science)

ARTIFICIAL INTELLIGENCE

(2017 Pattern) (Semester - I) (510501)

Time : 3 Hours]

[Max. Marks : 50

Instructions to the candidates:

- 1) *Attempt Q1 or Q2, Q3 or Q4, Q5 or Q6, Q7 or Q8.*
- 2) *Neat diagrams must be drawn wherever necessary.*
- 3) *Figures to the right indicate full marks.*
- 4) *Assume suitable data, if necessary.*

Q1) What is an Intelligent agent? Explain the high level architecture of intelligence agent. **[9]**

OR

Q2) Explain Bayes theorem in probabilistic reasoning. **[9]**

Q3) Compare informed and un informed searches. Give an informed search with example and pseudocode. **[9]**

OR

Q4) Explain reinforcement learning. **[9]**

Q5) a) What is resolution by refutation? Explain with an example and pseudocode. **[8]**

b) Explain forward space planning with an example. **[8]**

OR

Q6) a) Explain the applications of AI in credit card fraud analysis. **[8]**

b) What is recommender system? How do you predict rating in recommender system? **[8]**

P.T.O.

- Q7)** a) Give the air cargo transport application in PDDL. [8]
b) Explain unification algorithm in inference of first order logic. [8]

OR

- Q8)** a) What is Hill climbing search? Explain with pseudocode and its limitations. [8]
b) How do you apply genetic algorithm in n queens problem? [8]



Total No. of Questions : 12]

SEAT No. :

PA-638

[Total No. of Pages : 2

[5928]-79

**M.E. (Artificial Intelligence of Data Science)
VIRTUAL REALITY AUGMENTED REALITY
(2017 Pattern) (Semester-II) (510504)**

Time : 3 Hours]

[Max. Marks : 50

Instructions to the candidates:

- 1) *Attempt Q1 or Q2, Q3 or Q4, Q5 or Q6, Q7 or Q8, Q9 or Q10, Q11 or Q12.*
- 2) *Neat diagram must be drawn wherever necessary.*
- 3) *Figures to the right side indicates full marks.*
- 4) *Assume suitable data if necessary.*

Q1) a) Explain how Geometric modeling is done. **[4]**

b) How 3D rotation done? Explain. **[4]**

OR

Q2) a) Compare VR with MR. **[4]**

b) Explain various navigation tools. **[4]**

Q3) How does the VR create depth perception. **[8]**

OR

Q4) What is multi-frame Rate Rendering. **[8]**

Q5) How SLAM is use in different applications. **[9]**

OR

Q6) What is outdoor tracking is done? Explain with examples? **[9]**

Q7) Enlist the type of marker with respect to AR? Explain any one in details? **[9]**

OR

Q8) What is difference between markerless of marker AR? **[9]**

P.T.O.

Q9) Explain in details VR content creation. [8]

OR

Q10) Write overview of game development in unity IDE. [8]

Q11) Write a short note on:

a) VR SDK

b) AR TOOLKIT

[8]

OR

Q12) Explain AR core and AR Toolkit in details? [8]



Total No. of Questions: 10]

SEAT No. :

PA-585

[5928]-8

[Total No. of Pages : 2

M.E. (Civil) (Construction Management)
ENVIRONMENT AND ENERGY FOR SUSTAINABLE
CONSTRUCTION
(2017 Pattern) (Semester-III) (601033)

Time : 3 Hours]

[Max. Marks : 50

Instructions to the candidates:

- 1) *Attempt Q.1 or Q.2, Q.3 or Q.4, Q.5 or Q.6, Q.7 or Q.8, Q.9 or Q.10.*
- 2) *Neat diagram must be drawn wherever necessary.*
- 3) *Figures to the right indicate full marks.*
- 4) *Assume suitable data, if necessary and clearly state.*
- 5) *Use of cell phone is prohibited in the examination hall.*
- 6) *Use of electronic pocket calculator is allowed.*

- Q1)** a) Explain the concept of Environment. What are the different Environmental Impact Factors to be considered when construct the Airports? [5]
b) Explain the steps involved in EIA Process. [5]

OR

- Q2)** a) Enlist basic steps involved in Socio economic assessment. [5]
b) What do you mean of "Fiscal impacts Analysis". Write down its importance. [5]

- Q3)** a) Enlist the different types of Environment and pollution control Laws in India. Explain any one in detail. [5]
b) Explain the Role of Financial Institutions and corporate banks for Energy Efficient Projects. [5]

OR

- Q4)** a) Explain the outline of basic steps in performing the socio economic assessment for Post COVID [5]
b) Explain in details on COP? [5]

- Q5)** a) Explain differed payment financing? [5]
b) Explain the ESCOs and their role in development of energy efficient projects. [5]

OR

P.T.O.

- Q6)** a) Explain the Role of UNFCCC. [5]
b) Explain CDM? Explain the Methodology & Procedures for CDM in detail. [5]

- Q7)** a) Explain the ESCOs and their role in development of energy efficient projects. [5]
b) Explain thermal phenomena and active HVAC system used in energy efficient structures? [5]

OR

- Q8)** a) Explain points should be considered to carry energy audit of a building? [5]
b) Explain what is meant by passive heating with neat sketch. [5]

- Q9)** a) Explain what is energy management and its importance. [5]
b) Explain how to improve power factor. [5]

OR

- Q10)**a) Explain differed payment financing? [5]
b) Explain on improvement of boiler efficiency. [5]



Total No. of Questions : 8]

SEAT No. :

PA-2675

[Total No. of Pages : 2

[5928]-80

**M.E. Computer (Artificial Intelligence & Data Science)
SOFT COMPUTING & DEEP LEARNING
(2017 Pattern) (Semester - III) (610501)**

Time : 3 Hours]

[Max. Marks : 50

Instructions to the candidates:

- 1) *Answer any five questions.*
- 2) *Neat diagrams must be drawn wherever necessary.*
- 3) *Figures to the right side indicate full marks.*
- 4) *Assume suitable data if necessary.*

- Q1)** a) Why is Hybrid soft computing Systems are required? Explain any one of the Hybrid System Approaches in Soft computing with neat diagram explaining its application in real world. [4]
- b) Explain working of Genetic algorithms with encoding, selection and various operators. [4]
- c) How you will compare Classical sets any Fuzzy sets. [2]
- Q2)** a) Draw block diagram for Fuzzy Expert system and explain working of each Block. [4]
- b) Explain fuzzification with any two fuzzification methods. [4]
- c) What to defuzzification? Why it is required? [2]
- Q3)** a) What are applications Deep Neural Network? Explain its working with diagram. [4]
- b) Explain Neural network architectures: back propagation algorithm. [4]
- c) Compare Shallow and Deep Neural Networks. [2]
- Q4)** a) Explain with example how ReLU heuristics are applied to avoid to bad local optima. [4]
- b) Explain Learning Parameters of a feedforward neural network. [4]
- c) Why PCA is used in Deep Learning. [2]

P.T.O.

- Q5)** a) What is application Guided back propagation as a variation in Neural network. [4]
b) What is the problem of the vanishing/exploding gradient. How RenNet Handles the problem of the vanishing/exploding gradient? [4]
c) Write Any two applications of Convolutional Neural Networks. [2]
- Q6)** a) What is need of LSTM? Draw and explain working of LSTM. [4]
b) Explain working principal of RNN. [4]
c) Why to apply GRU in sequence models? [2]
- Q7)** a) Design washing machine controller applying fuzzy techniques. [5]
b) Design a model applying Genetic Algorithm in solving resource planning problem. [5]
- Q8)** a) Write a Short note on various Cross over operators used in GA. [5]
b) Design a solution to solve 0-1 knapsack problem using Genetic Algorithms. Explain with example how you will implement this using suitable encoding, Crossover, and Mutation techniques along with selection of Objective function. [5]



Total No. of Questions : 12]

SEAT No. :

PA-3159

[Total No. of Pages : 2

[5928]-81

M.E (Artificial Intelligence and Data Science)

SCALABLE DATA SCIENCE

(2017 Pattern) (Semester - III) (610502)

Time : 3 Hours]

[Max. Marks : 50

Instructions to the candidates:

- 1) *Answer Q1 or Q2, Q3 or Q4, Q5 or Q6, Q7 or Q8, Q9 or Q10, Q11 or Q12.*
- 2) *Neat diagrams must be drawn wherever necessary*
- 3) *Figures to the right indicate full marks.*
- 4) *Assume suitable data if necessary.*

Q1) Elaborate various challenges associated with big data analysis and discuss the use of bloom filter with suitable example. **[9]**

OR

Q2) Explain Misra-Gries sketch algorithm with suitable example. **[9]**

Q3) Compare and contrast RDDs versus Data frames. What are the benefits of using Data frames over RDDs? **[9]**

OR

Q4) Explain the use of RDDs transformations and actions WRT Apache Spark SQL. Compare and contrast RDDs versus Data Frames. **[9]**

Q5) Explain statistical calculations skewness, Kurtosis, Covariance, Covariance matrices using suitable examples. **[9]**

OR

Q6) List various correlation methods to achieve parallelism in Apache spark. **[9]**

P.T.O.

Q7) Enlist various API types that are compatible with Spark? How is feature selection used in pipeline? [9]

OR

Q8) Explain default level of parallelism in Apache Spark and give suitable example of K-Means clustering in Spark. [9]

Q9) Elaborate different kinds of graphs used in Spark? What are the structural operators provided in the Grapx library? [9]

OR

Q10) Can Apache Spark handle graph processing? Justify your answer. [9]

Q11) Elaborate set operations using Spark R data frames. Explain advantages and limitations of using R environment. [5]

OR

Q12) Explain how Spark is good at low latency workloads like graph processing and machine learning? [5]



Total No. of Questions : 8]

SEAT No. :

PA-2611

[Total No. of Pages : 2

[5928]-82

M.E. (Chemical Engg.)

MATHEMATICAL AND STATISTICAL METHODS

(2017 Pattern) (Semester-I) (Theory) (509101)

Time : 3 Hours]

[Max. Marks : 50

Instructions to the candidates:

- 1) Answer total 5 questions from the following.
- 2) Neat diagrams must be drawn wherever necessary.
- 3) Figures to the right indicate full marks.
- 4) Assume suitable data if necessary.

Q1) a) Solve the differential equation by power series method $y' - y = 0$. [5]

b) Expand the following function in terms of Legendre polynomials in the interval $-1 < x < 1$ $f(x) = x^2 + 2x^2 - x - 3$. [5]

Q2) a) Find the potential in the interior of a sphere of unit radius when the potential on the surface is $f(\theta) = \cos^2\theta$. [6]

b) Explain Laplace equation in cylindrical form. [4]

Q3) a) Obtain the Laplace's equation in two dimensions for heat flow. [5]

b) Write a note on series of complex terms. [5]

Q4) a) Evaluate $\int_0^{1+i} (x^2 + iy) dz$ along the paths $y = x$ and $y = x^2$. [5]

b) Find the Laurent's expansion of $f(z) = (7z - 2)/[(z + 1)z(z - 2)]$ in the region $1 < z < 3$. [5]

Q5) a) In a certain college, 4% of the boys and 1% of girls are taller than 1.8m. Further more 60% of the students are girls. If a student is selected at random and is found to be taller than 1.8m. What is probability that the student is a girl? [6]

b) State the steps in constructing Latin square & differentiate between statistics and parameter? [4]

P.T.O.

- Q6)** a) The mean of two single large samples of 1000 and 2000 members are 67.5 inches and 68.0 inches respectively. Can the samples be regarded as drawn from same population of standard deviation 2.5 inches (Test at 5% level of significance). [5]
- b) What types of errors are associated in testing hypothesis. [3]
- c) Distinguish between experimental and extraneous variables. [2]

- Q7)** a) The following data are the number of seeds germinating out of 10 on damp filter paper for 80 sets of seeds. Fit a binomial distribution to these data: [6]

X	0	1	2	3	4	5	6	7	8	9	10
Y	6	20	28	12	8	6	0	0	0	0	0

- b) Discuss the procedure to calculate the mean from ungrouped data? [4]

- Q8)** a) Write note on rank correlation coefficient. [5]

- b) Fit a straight line $y = a + bx$ to the following data by method of least squares. [5]

$x:$	0	1	3	6	8
$y:$	1	3	2	5	4



Total No. of Questions : 8]

SEAT No. :

PA-639

[Total No. of Pages : 2

[5928]-83

M.E. (Chemical Engineering)

PROCESS OPTIMIZATION

(2017 Pattern) (Semester - I)(509102)

Time : 3 Hours]

[Max. Marks : 50

Instructions to the candidates:

- 1) *Answer any five questions.*
- 2) *Neat diagrams must be drawn wherever necessary.*
- 3) *Figures to the right side indicate full marks.*
- 4) *Use of calculator is allowed.*
- 5) *Assume suitable data if necessary.*

Q1) a) Define Optimization. Explain Nature and Scope of Optimization. [5]

b) Write short note on unimodal and multimodal function. [5]

Q2) a) Explain in detail unimodal and multimodal function. [5]

b) Explain in detail Optimality Conditions for One Dimensional and Multi Dimensional Optimization. [5]

Q3) a) Minimize the function $f(x) = x(x - 1.5)$ in the interval (0, 1) using Exhaustive search method to within 10% of the exact value. [6]

b) Draw a flowchart of golden section method for one dimensional minimization problems. [4]

Q4) Explain Cubic Search Method and Successive Quadratic Estimation. [10]

P.T.O.

Q5) Solve the following using Powell's Method. **[10]**

$$F = X_1^2 + X_2^2 - 2X_1 - 4X_2 + 5$$

Q6) a) Explain the differences between Genetic Algorithm and traditional methods. **[5]**

b) What is fitness function in Genetic Algorithm? **[3]**

c) What is 'Mutation' in Genetic Algorithm? **[2]**

Q7) Minimize using Linear Programming: **[10]**

$$F = 4X + 5Y$$

Subjected to

$$10X + Y > 10$$

$$5X + 4Y > 20$$

$$3X + 7Y > 21$$

$$X + 12Y > 12$$

$$X > 0 \text{ and } Y > 0$$

Q8) Write short notes on:

a) Steps in simulated annealing algorithm. **[5]**

b) Priori approach for Multi-objective optimization. **[5]**



Total No. of Questions : 7]

SEAT No. :

PA-640

[Total No. of Pages : 2

[5928]-84

M.E. (Chemical Engineering)

ADVANCED SEPARATION PROCESSES

(2017 Pattern) (Semester - I) (509103)

Time : 3 Hours]

[Max. Marks : 50

Instructions to the candidates:

- 1) *Answer any five questions.*
- 2) *Neat diagrams must be drawn wherever necessary.*
- 3) *Figures to the right indicate full marks.*
- 4) *Use of an electronic pocket calculator is allowed.*
- 5) *Assume suitable data, if necessary.*
- 6) *Use of cell phone or Mobile phone is strictly prohibited in the examination hall.*

Q1) a) Explain in brief recent advances in separation techniques based on size, surface properties, ionic properties. **[7]**

b) State types and choice of membranes. **[3]**

Q2) a) Describe in brief : Spiral Wound module with a neat diagram. **[5]**

b) Write a short note on Sirofloc filter. **[5]**

Q3) a) Explain in brief various adsorption techniques. **[5]**

b) Describe in brief Gas Chromatographic technique. **[5]**

P.T.O.

Q4) a) Which are different types and choice of adsorbents and adsorption isotherms? [5]

b) Describe in brief PSA and TSA process in adsorption. [5]

Q5) Explain in brief working principle, mechanism and Design aspects of Prevpaporation with Schematic diagram. [10]

Q6) a) Explain in brief equipment used for electrophoresis. [7]

b) State applications of Ion-Exchange. [3]

Q7) a) Distinguish between Reactive distillation and Reactive extraction. [5]

b) Write a short note on : Supercritical fluid extraction. [5]



Total No. of Questions : 8]

SEAT No. :

PA-641

[Total No. of Pages : 2

[5928]-85

M.E. (Chemical)

RESEARCH METHODOLOGY

(2017 Pattern) (Semester - I) (509104)

Time : 3 Hours]

[Max. Marks : 50

Instructions to the candidates:

- 1) *Answer any five questions.*
- 2) *Neat diagrams must be drawn whenever necessary.*
- 3) *Figures to the right side indicate full marks.*
- 4) *Use of calculator is allowed.*
- 5) *Assume suitable data, if necessary.*

Q1) a) What are the different types of research? Discuss the importance of applied research with suitable example. **[5]**

b) Research is nothing but proper fact finding method. Do you agree or disagree with this statement? Give suitable reasoning and example to support your answer. **[5]**

Q2) a) Calculate the correlation coefficient between following variables A & B. Use the following data table: **[5]**

A	1	3	5	7	8	10
B	8	12	15	17	18	20

b) Explain how to carry out linear regression analysis using computer program. What is the significance of R² value? **[5]**

Q3) a) What do you mean by experimental design. Explain in detail various steps used in experimental design. **[5]**

b) Explain in detail factorial (2^K) design with a suitable example. **[5]**

P.T.O.

- Q4)** a) Explain the criteria of goodness of a measurement scale. [5]
b) Enumerate the different methods of collecting data. [5]
- Q5)** a) How error analysis is done? Generally what percent of limit is allowed in error analysis? [6]
b) Explain the various criteria for choosing right graph. Support your answer with suitable examples. [4]
- Q6)** a) Write a short note on 'Experience Survey' explaining fully its utility in exploratory research studies. [5]
b) Discuss the important factors to be considered during presenting a research idea. [5]
- Q7)** a) Explain in detail the different types of citation methods. [5]
b) Write a note on "Plagrism in research". [5]
- Q8)** Explain the difference in journal publications, conference and short communication. Discuss about impact factor of a research journal. [10]



[5928]-86

M.E. (Chemical Engineering)

ADVANCED TRANSPORT PHENOMENA

(2017 Pattern) (Semester - II) (509107) (Paper - I)

Time : 3 Hours]

[Max. Marks : 50

Instructions to the candidates:

- 1) Answer any five questions.
- 2) Assume suitable data, if necessary.
- 3) Neat diagram must be drawn wherever necessary.
- 4) Use of electronic pocket calculator is allowed.

Q1) Derive the following velocity profile relation of a fluid flowing inside a circular pipe, starting with the continuity equation and the r , θ and z -equation of motion. Assume no radial and tangential flow components. [10]

$$v_z = \frac{(\mathcal{P}_0 - \mathcal{P}_1)R^2}{4\mu L} \left[1 - \left(\frac{r}{R} \right)^2 \right]$$

Q2) A semi-infinite body of liquid with constant density and viscosity is bounded below by a horizontal surface (the xz -plane). Initially the fluid and the solid are at rest. Then at time $t = 0$, the solid surface is set in motion in the positive x direction with velocity v_0 as shown in Fig. Find the velocity v_x as a function of y and t . There is no pressure gradient or gravity force in the x direction, and the flow is presumed to be laminar. [10]

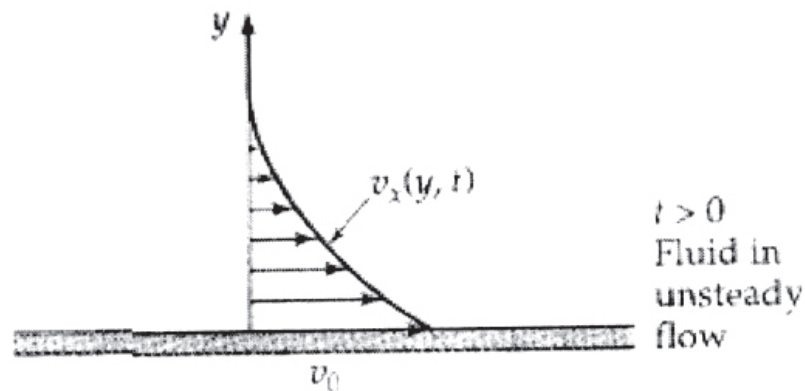

P.T.O.

Q3) Derive the following temperature profile equation for a cylindrical wire with electric heat source assuming $S_c = I^2 / k$ as the rate of heat production per unit

$$\text{volume. } T - T_0 = \frac{S_c R^2}{4k} \left[1 - \left(\frac{r}{R} \right)^2 \right] \quad [10]$$

Q4) Derive the final equation of energy change for Non-isothermal systems starting from the basic conservation of energy equations with suitable assumptions. [10]

Q5) Discuss the time-smoothing of the equations of continuity and motion for component 'A' disappearing by an n^{th} order chemical reaction in rectangular coordinates. [10]

Q6) A fluid stream emerges from a chemical plant with a constant mass flow rate w and discharges into a river (see Fig.). It contains a waste material A at mass fraction W_A , which is unstable and decomposes at a rate proportional to its concentration according to the expression, $r_A = -k_1 \rho_A$ that is, by a first-order reaction. To reduce pollution it is decided to allow the effluent stream to pass through a holding tank of volume V , before discharging into the river. The tank is equipped with an efficient stirrer that keeps the fluid in the tank at very nearly uniform composition. At time $t = 0$ the fluid begins to flow into the empty tank. No liquid flows out until the tank has been filled up to the volume V . Develop an expression for the concentration of the fluid in the tank as a function of time, both during the tank-filling process and after the tank has been completely filled. [10]

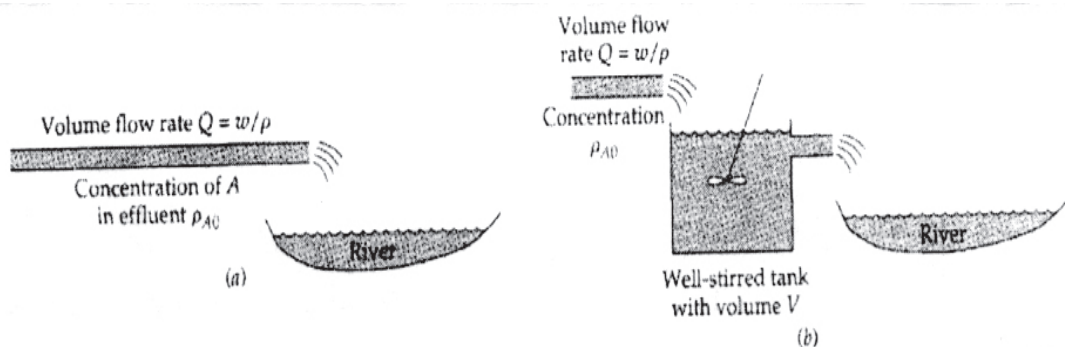
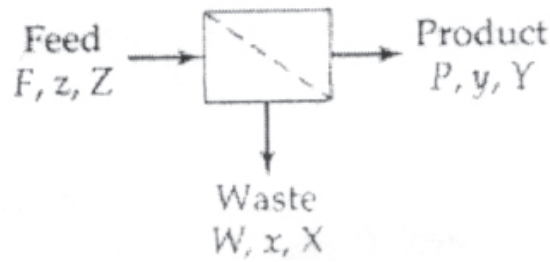

Fig. Effluent Discharge,

- a) Effluent discharged to river,
- b) Effluent decomposed in CSTR and then discharged to river.

Q7) Describe the operation of a binary splitter in terms of macroscopic model, one of the commonest and simplest separation devices (see Fig.) Here a binary mixture of A and B enters the apparatus in a feed stream at a molar rate F , and by some separation mechanism it is split into a product stream with a molar rate P and a waste stream with molar rate W . The mole fraction of A (the desired component) in the feed stream is z , and the mole fractions in the product and waste streams are y and x , respectively. [10]



Binary Splitter

- Q8) a)** Discuss the Chilton & Colburn ‘J’ factor analogy in brief. [5]
- b) A spherical drop of water, 0.05 cm in diameter, is falling at a velocity of 215 cm/s through dry, still air at 1 atm pressure with no internal circulation. Estimate the instantaneous rate of evaporation from the drop, when the drop surface is at $T_0 = 70^\circ\text{F}$ and the air (far from the drop) is at $T_\infty = 140^\circ\text{F}$. The vapor pressure of water at 70°F is 0.0247 atm. Assume quasi-steady state conditions. Neglect the solubility of air in water. Data required : $c = 3.88 \times 10^{-5}$ gmoles/cm³, $\rho = 1.12 \times 10^{-3}$ g/cm³, $\mu = 1.91 \times 10^{-4}$ g/cm.s, $D_{AB} = 0.292$ cm²/s. [5]



Total No. of Questions : 8]

SEAT No. :

PA-643

[Total No. of Pages : 2

[5928]-87

M.E. (Chemical Engineering)

ADVANCED PROCESS CONTROL

(2017 Pattern) (509108) (Semester - II)

Time : 3 Hours]

[Max. Marks : 50

Instructions to the candidates :

- 1) Answer any five questions.
- 2) Neat diagrams must be drawn wherever necessary.
- 3) Figures to the right side indicate full marks.
- 4) Use of calculator is allowed.
- 5) Assume suitable data if necessary.

Q1) a) Discuss the State-space representation of a chemical process. [5]

b) What is Process Identification? State the differences between Theoretical Modeling and Process Identification. [5]

Q2) A 2×2 MIMO process has the following steady-state gain matrix [10]

$$K = \begin{bmatrix} 1 & 0 \\ 10 & 1 \end{bmatrix}$$

Calculate the singular values and the condition number of the system and comment on the conditioning of the system.

Q3) Explain the stability analysis of Discrete-time systems in the complex plane.[10]

Q4) Design a controller for the first-order process whose transfer function is given by: [10]

$$g(s) = \frac{5.0}{8s + 1}$$

Using the IMC strategy. Convert this controller to the conventional feedback form.

P.T.O.

Q5) Discuss the important issues in Plant wide Control of a chemical process.[10]

Q6) a) Explain in detail the Override control of a boiler system with neat figure. [5]

b) What is Cascade Control? Explain the cascade control of a jacketed CSTR with a neat diagram. [5]

Q7) Explain the concepts of Dynamic Matrix Control (DMC) with equations and the response graph. [10]

Q8) Design a controller for the following first-order system using the Direct Synthesis controller design approach : [10]

$$g(s) = \frac{0.66}{6.7s + 1}$$



Total No. of Questions : 8]

SEAT No. :

PA-644

[Total No. of Pages : 2

[5928]-88

M.E. (Chemical Engineering)
ADVANCED REACTION ENGINEERING
(2017 Pattern) (Semester -II) (509109)

Time : 3 Hours]

[Max. Marks : 50

Instructions to the candidates:

- 1) *Answer any five questions.*
- 2) *Neat diagrams must be drawn wherever necessary.*
- 3) *Figures to the right indicate full marks.*
- 4) *Use of logarithmic tables slide rule, Mollier charts. Electronic pocket calculator and steam tables is allowed.*
- 5) *Assume suitable data, if necessary.*

Q1) Explain in detail segregated flow model and dispersion model with help of sketch for the analysis of non-ideal reactors. **[10]**

Q2) Calculate the mass flux of reactant A to a single catalyst pellet 1 cm in diameter suspended in a large body of liquid. The reactant is present dilute concentrations, and the reaction is considered to take place instantaneously at the external pellet surface (i-e $C_{As} = 0$). The bulk concentration of reactant is 1.0 M and the free system liquid velocity is 0.1 m/s. The kinematic viscosity is 0.5 centistoke and the liquid diffusivity of A is 10^{-10} m²/sec, T = 300K. **[10]**

Q3) Explain in details modelling diffusion with reaction. **[10]**

Q4) Discuss about: **[10]**

- a) State of aggregation.
- b) Earliness and lateness of fluid mixing in the vessel.

Q5) Derive the expression relating time and conversion for shrinking core model for spherical particles of radius R and unreacted core radius r_c of unchanging size for diffusion through ash layer control. **[10]**

P.T.O.

Q6) Write a detail note on: **[10]**

- a) Effectiveness factor.
- b) Progressive conversion model.

Q7) Determine the amount of catalyst required in packed bed reactor for 80% conversion of 1000 mol/min if $C_{A0} = 8 \text{ mol/m}^3$ of feed. **[10]**

Q8) Write note on isothermal and adiabatic fixed bed reactors with suitable illustration. **[10]**



Total No. of Questions : 8]

SEAT No. :

PA-645

[Total No. of Pages : 1

[5928]-89

M.E. (Chemical)

PROCESS MODELING & SIMULATION

(2017 Pattern) (Semester - III) (509113)

Time : 3 Hours]

[Max. Marks : 50

Instructions to the candidates:

- 1) Answer any 5 questions.*
- 2) Neat diagrams must be drawn wherever necessary.*
- 3) Assume suitable data, if necessary.*
- 4) Use of logarithmic tables, slide rule, Mollier charts, electronic pocket calculator and steam tables is permitted.*

Q1) Define Model and also explain the need of modeling. **[10]**

Q2) Explain different Unsteady State Models. **[10]**

Q3) Explain Linear and non-linear regression. **[10]**

Q4) Develop a model for Batch Reactor. **[10]**

Q5) Write assumption for a model of distillation column & develop a model. **[10]**

Q6) Give the simulation scheme for CSTR. Explain it with a case study. **[10]**

Q7) A patient just had surgery and is required to have at least 81 units of drug D1 and 120 units of drug D2 each day. Assume that an over dosage of either drug is harmless. Each gram of substance M contains 10 units of D1 and 8 units of drug D2 and each gram of substance N contains 2 units of D1 and 4 units of D2. Now suppose that both M and N contain an undesirable drug D3, 3 units per gram in M and 1 unit per gram in N. Find how many grams of substances M and N should be taken in order to meet the requirements and minimize the intake of D3 at the same time. **[10]**

Q8) Explain Application of Optimization pertaining to Chemical Reactor. **[10]**



Total No. of Questions : 08]

SEAT No. :

PA-586

[Total No. of Pages : 2

[5928]-9

M.E. (Civil) (Construction Management)
RESEARCH METHODOLOGY
(2017 Pattern) (Semester - III) (601034)

Time : 3 Hours]

[Max. Marks : 50

Instructions to the candidates:

- 1) *Attempt Q. 1 or Q. 2, Q. 3 or Q. 4, Q.5 or Q. 6 and Q. 7 or Q. 8.*
- 2) *Neat diagram must be drawn wherever necessary.*
- 3) *Figures to the right indicate full marks.*
- 4) *Assume suitable data, if necessary.*
- 5) *Use of electronic pocket calculator is allowed.*

Q1) a) Enlist steps involved in a research process. [4]

b) Discuss elements and objectives of literature survey. [5]

OR

Q2) a) What do you mean by research? Describe the different types of research [5]

b) What do you mean by literature survey? Explain its need. [4]

Q3) a) What are the merits and demerits of collection of data through questionnaires? [4]

b) What is a hypothesis? Explain basic concepts concerning testing of hypothesis. [5]

OR

Q4) a) Explain the criteria of goodness of a measurement scale. [5]

b) Explain the meaning of analysis of variance. Describe briefly the technique of analysis of variance. [4]

P.T.O.

- Q5)** a) What is the main objective of factor analysis? What is the difference between discriminant analysis and cluster analysis? [8]
b) Discuss factor analysis and discriminant analysis. [8]

OR

- Q6)** a) Explain various methods of factor analysis in brief. What is the difference between cluster analysis and factor analysis? [8]
b) What are the several multidimensional scaling techniques? Write short notes on significance of multidimensional scaling. [8]

- Q7)** a) Explain the different steps involved in obtaining patent. Explain the difference between product patent and process patent. [8]
b) Mention the different types of report. Differentiate technical report and a popular report. [8]

OR

- Q8)** a) What is research paper and how to write it? [8]
b) Write short notes on presentation styles, patent procedure, and impact of presentation and elements of effective presentation. [8]



Total No. of Questions : 8]

SEAT No. :

PA-646

[Total No. of Pages : 2

[5928] - 90

M.E. (Chemical Engg.)

ADVANCED THERMODYNAMICS

(2017 Pattern) (Semester - III) (Paper - I) (509114)

Time : 3 Hours]

[Max. Marks : 50

Instructions to the candidates :

- 1) Answer any five questions
- 2) Assume suitable data, if necessary.
- 3) Neat diagrams must be drawn wherever necessary
- 4) Use of electronic pocket calculator is allowed

Q1) Describe the common three types of binary Liquid-Liquid Equilibrium (LLE) solubility diagrams in detail. [10]

Q2) The van Laar constant A and B for the system of Nitromethane and CCl_4 at 45°C are 2.23 and 1.95 respectively. Calculate the ratio between activity coefficients of Nitromethane and CCl_4 in the solution containing 30 mol% Nitromethane. [10]

Q3) Acetic acid is esterified in the liquid phase with ethanol at 100°C and atmospheric pressure to produce ethyl acetate and water according to the reaction :

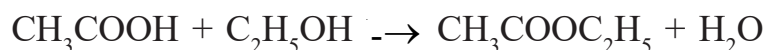

If initially there is one mole each of acetic acid and ethanol, estimate the mole fraction of ethyl acetate in the reacting mixture at equilibrium.

Data given : $\Delta H^\circ_{\text{R}} = -3640\text{J}$, $\Delta G^\circ_{\text{R}} = -4650\text{J}$, assume deal solution behavior of the species. [10]

P.T.O.

- Q4)** a) Estimate the maximum flame temperature that can be attained by a burner if hydrogen gas at 1 bar and 298 K is used as fuel. The combustion products leave the burner at 1 bar. Assume a constant heat capacity of H_2O as 41 J/mol K. The standard heat of reaction for the oxidation of hydrogen is -241.99 kJ. [5]
- b) Explain the effect of temperature on the reaction equilibrium from thermodynamic point of view. [5]
- Q5)** a) Explain the Boltzmann's Entropy Concept based on statistical probabilities. [5]
- b) A closed box contains two equal portions initially closed by a partition with each portion containing 3 molecules each (total 6 molecules in the box). Determine the number of most probable macro-states and the change in entropy of the system while going from the least likely state to the most likely state. The Boltzmann constant is $K_b = 1.38 \times 10^{-23}$ J/K. [5]
- Q6)** Write short note on Canonical Ensembles proposed in Statistical Thermodynamics. [10]
- Q7)** Explain the Onsager reciprocal relations law formulated for non-equilibrium thermodynamics. [10]
- Q8)** Explain the conductor-superconductor transition from thermodynamic point of view. [10]



Total No. of Questions : 8]

SEAT No. :

PA-647

[Total No. of Pages : 2

[5928]-91

M.E. (Environmental Engineering) (Chemical)
APPLIED STATISTICS FOR ENVIRONMENTAL
ENGINEERS

(2017 Pattern) (Semester - I) (509131)

Time : 3 Hours]

[Max. Marks : 50

Instructions to the candidates:

- 1) *Answer any five questions.*
- 2) *Neat diagrams must be drawn wherever necessary.*
- 3) *Figures to the right indicate full marks.*
- 4) *Use of logarithmic tables slide rule, Mollier charts, electronic pocket calculator and steam tables is allowed.*
- 5) *Assume suitable data, if necessary.*

- Q1)** a) State the difference between mean deviation and standard deviation. [5]
b) Explain residual error in regression model. [5]

- Q2)** In a partially destroyed laboratory, record of an analysis of correlation data, the following results were legible : [10]

Variance of X = 9, Regression equations :

$$8X - 10Y + 66 = 0, 40X - 18Y = 214$$

What are :

- a) The mean value X and Y
 - b) The correlation coefficient between X and Y
 - c) The standard deviation of Y
- Q3)** Explain in detail Correlation and Autocorrelation with examples and plots. [10]
- Q4)** a) State and explain the assumptions in analysis of variance. [5]
b) Elaborate model equation for latin square design. [5]

P.T.O.

- Q5)** a) Comment on factorial experimentation with suitable example. [5]
 b) Establish relation between t and f distribution. [5]

Q6) The following are the average losses of worker - hours due to accidents in 10 industrial plants before and after a certain safety program was put into operation : [10]

Before	45	73	46	124	33	57	83	34	26	17
After	36	60	44	119	35	51	77	29	24	11

Use the 0.05 level of significance to test whether the safety program is effective.

Q7) Explain randomized block design model with suitable illustration. [10]

Q8) Explain graphical Sensitivity analysis in the light of simplex method. [10]



Total No. of Questions : 8]

SEAT No. :

PA-648

[Total No. of Pages : 2

[5928]-92

**M.E. (Chemical Engineering) (Environmental)
ENVIRONMENTAL MANAGEMENT
(2017 Pattern) (Semester - I) (509132)**

Time : 3 Hours]

[Max. Marks : 50

Instructions to the candidates:

- 1) *Answer any five questions.*
- 2) *Neat diagrams must be drawn wherever necessary.*
- 3) *Figures to the right side indicate full marks.*
- 4) *Use of calculator is allowed.*
- 5) *Assume suitable data if necessary.*

Q1) a) Explain the different Environmental management standards for Chemical Industries. [5]

b) Discuss the various advantages of Environmental Auditing. [5]

Q2) a) Discuss trade and environmental management. [5]

b) Explain EIA evaluation in India. [5]

Q3) a) What is 74th amendment of the constitutions. [5]

b) What are the features of the directive principles of state policy? [5]

Q4) a) Explain command and control regulations. [4]

b) Explain how a rule is notified and gazetted. [3]

c) What are the different environmental acts? [3]

P.T.O.

- Q5)** a) Explain fundamental rights and duties of Indian citizens. [5]
b) Write short note on general procedure for Risk assessment. [5]
- Q6)** a) Discuss the various factory acts passed by Indian government. [5]
b) Give the difference between regulations and laws. [5]
- Q7)** a) Explain the role of Maharashtra Pollution Control Board for sustainable growth. [5]
b) Discuss carbon trading. [5]
- Q8)** a) Explain the role of Ministry of forest for conservation of environment. [5]
b) Discuss general features of annual report of Ministry of Environment for current year. [5]



Total No. of Questions : 8]

SEAT No. :

PA-649

[Total No. of Pages : 2

[5928]-93

M.E. (Chemical Engg.) (Environmental)
ENVIRONMENTAL CHEMISTRY
(2017 Pattern) (Semester - I) (509133)

Time : 3 Hours]

[Max. Marks : 50

Instructions to the candidates:

- 1) Answer any 5 questions.*
- 2) Neat diagrams must be drawn wherever necessary.*
- 3) Figures to the right indicate full marks.*
- 4) Use of logarithmic tables rule, Mollier charts, electronic pocket calculator and steam tables is allowed.*
- 5) Assume suitable data, if necessary.*

Q1) What is TDS? Explain its environmental significance and determination Technique. **[10]**

Q2) What is the role of Stoichiometry in Environmental Chemistry? Explain with suitable example. **[10]**

Q3) What is the cause of contaminated soils? How to treat the contaminated soils? **[10]**

Q4) Why the Air sampling is important explain in detail. **[10]**

Q5) What are the sources of particulate matter in Thermal power plant? **[10]**

Q6) What is Nano material? Explain its use in Environmental Engineering. **[10]**

P.T.O.

Q7) What is exchange capacity of adsorbent? How to determine it. [10]

Q8) What is Isokinetic sampling? Explain in detail. [10]



Total No. of Questions : 8]

SEAT No. :

PA-650

[Total No. of Pages : 2

[5928]-94

M.E. Engineering (Chemical Environmental)
RESEARCH METHODOLOGY
(2017 Pattern) (Semester - I) (509134)

Time : 3 Hours]

[Max. Marks : 50

Instructions to the candidates:

- 1) *Answer any 5 questions.*
- 2) *Neat diagrams must be drawn wherever necessary.*
- 3) *Figures to the right indicate full marks.*
- 4) *Assume suitable data if necessary.*

Q1) a) What do you mean by research? Explain its significance in modern times. [5]

b) Explain in detail about the critical Literature Review. [5]

Q2) a) Explain in detail about the Mathematical tools for analysis. [5]

b) Discuss the criteria for choice of topic of research. [5]

Q3) a) How do you estimate mean deviation? Sum of squares between samples and sum of squares within sample? [5]

b) Discuss about the problem based learning. [5]

Q4) Explain the Tabular and graphical presentation of data in research. [10]

Q5) Discuss the linear regression analysis and explain the role of computer program in carrying this regression analysis. [10]

P.T.O.

Q6) Discuss the Neural Network based optimization in research. **[10]**

Q7) How to prepare the research proposal? Discuss about the estimation of budget and activity chart for the proposed project. **[10]**

Q8) Write short notes on following : **[10]**

a) Licensing and transfer of technology

b) Process of Patenting



Total No. of Questions :8]

SEAT No. :

PA-651

[Total No. of Pages : 2

[5928]-95

**M.E. Chemical (Environmental Engineering)
WASTEWATER TREATMENT & DESIGN
(2017 Pattern) (Semester-II) (509137)**

Time : 3 Hours]

[Max. Marks : 50

Instructions to the candidates:

- 1) *Answer any 5 questions.*
- 2) *Neat diagrams must be drawn wherever necessary.*
- 3) *Figures to the right indicate full marks.*
- 4) *Use of logarithmic tables slide rule, Molier charts, electronic pocket calculator and steam table is allowed.*
- 5) *Assume suitable data, if necessary.*

Q1) Explain configurations for ideal and nonideal reactors. **[10]**

Q2) a) Explain mass transport processes. **[5]**

b) What are the important factors to be considered for selecting unit operations and processes. **[5]**

Q3) A dual -medium filter bed composed of sand and anthracite is to be used for the filtration of settled secondary effluent. If the effective size of the sand in the dual- medium filter is to be 0.55 mm, determine the effective size of the anthracite to avoid significant intermixing. Data: Specific gravity for sand = 2.65, Specific gravity for anthracite = 1.7. **[10]**

Q4) a) Discuss general features of conventional rapid granular medium depth filters. **[5]**

b) What is backwash hydraulics. **[5]**

Q5) a) How activated carbons are prepared and explain carbon regeneration and reactivation. **[5]**

b) Explain the concept of uptake capacity. **[5]**

P.T.O.

Q6) a) Explain the applications of ion exchange for hardness and TDS removal. [5]

b) Discuss disinfection with ozone. [5]

Q7) Determine the capacity of a chlorinator for a treatment plant with an average wastewater flow of 1000 m³/d. The peak daily factor for the treatment plant is 3.0 and the maximum required chlorine dosage is to be 20 mg/L. [10]

Q8) a) Explain Principle and working of Trickling filter. [5]

b) Discuss the general design consideration for anaerobic treatment process. [5]



Total No. of Questions : 10]

SEAT No. :

PA-652

[Total No. of Pages : 1

[5928]-96

M.E. (Chemical Engineering) (Environmental)

SOLID WASTE MANAGEMENT

(2017 Pattern) (Semester - II) (509138)

Time : 3 Hours]

[Max. Marks : 50

Instructions to the candidates :

- 1) Answer Q.1 or Q.2, Q.3 or Q.4, Q.5 or Q.6, Q.7 or Q.8 Q.9 or Q.10.*
- 2) Figures to the right indicates full marks.*

Q1) Illustrate the functional elements of the solid waste management. [10]

OR

Q2) Give the chemical and biological properties of the solid waste. [10]

Q3) Explain the transportation of the solid waste in detail. [10]

OR

Q4) Analyze the economics of solid waste generation rate. [10]

Q5) Explain the typical material recovery facility for a commercial solid waste.[10]

OR

Q6) Explain the vermicomposting and its impact on the environment. [10]

Q7) Explain the biomethanation and its impact on the environment. [10]

OR

Q8) Explain the energy recovery system from the biomethanation. [10]

Q9) Explain the various landfilling methods in detail. [10]

OR

Q10) Explain the elements of functional management plan for solid waste system.[10]



Total No. of Questions : 8]

SEAT No. :

PA-653

[Total No. of Pages : 1

[5928]-97

M.E. (Chemical) (Environmental Engineering)

INDUSTRIAL WASTE TREATMENT

(2017 Course) (509139) (Semester-II)

Time : 3 Hours]

[Max. Marks : 50

Instructions to the candidates:

- 1) *Answer any five questions.*
- 2) *Neat diagram must be drawn wherever necessary.*
- 3) *Figures to the right side indicate full marks.*
- 4) *Use of calculator is allowed.*
- 5) *Assume suitable data, if necessary.*

Q1) Write down about industrial water quality requirements. [10]

Q2) Write short notes water budgeting. [10]

Q3) Explain Tertiary treatments for industrial wastewater. [10]

Q4) Explain the concept of reuse and recycling concepts. [10]

Q5) Explain the treatment techniques for the removal of radioactive materials from industrial wastewater with neat flow diagram. [10]

Q6) Draw the flow sheet for treatment of fertilizer industry waste and focus on its cost benefit analysis with all details. [10]

Q7) Explain the design and cost-benefit analysis of common ETP plant. [10]

Q8) Write note on stream and Effluent standards in wastewater treatment plant.[10]



Total No. of Questions : 8]

SEAT No. :

PA-654

[Total No. of Pages : 1

[5928]-98

**M.E. (Chemical Engineering) (Environmental)
REMOTE SENSING AND GIS APPLICATIONS IN
ENVIRONMENTAL ENGINEERING
(2017 Pattern) (Semester - III) (509143)**

Time : 3 Hours]

[Max. Marks : 50

Instructions to the candidates:

- 1) *Answer any five questions.*
- 2) *Neat diagrams must be drawn wherever necessary.*
- 3) *Figures to the right side indicate full marks.*
- 4) *Use of calculator is allowed.*
- 5) *Assume suitable data, if necessary.*

- Q1)** a) Explain Remote Sensing technique and its application. [5]
b) Explain Active and Passive Remote Sensing system. [5]
- Q2)** Explain in detail the various satellites in orbit and their sensors in detail. [10]
- Q3)** Describe active system of data acquisition and explain any two basic types of radar. [10]
- Q4)** Differentiate between analog and digital system of remote sensing. [10]
- Q5)** Write short notes on [10]
a) Image classification
b) Indian remote sensing satellites
- Q6)** Explain the Spectral response of natural earth surface features. [10]
- Q7)** Explain concept of G.I.S. and state any four components of G.I.S. [10]
- Q8)** Explain waste water management by using remote sensing & G.I.S. [10]



Total No. of Questions : 8]

SEAT No. :

PA-655

[Total No. of Pages : 2

[5928] - 99

M.E. (Chemical Engineering) (Environmental)

INDUSTRIAL POLLUTION PREVENTION & CLEANER PRODUCTION

(2017 Pattern) (Semester - III) (509144)

Time : 3 Hours]

[Max. Marks : 50

Instructions to the candidates :

- 1) *Answer any five questions.*
- 2) *Neat diagrams must be drawn wherever necessary.*
- 3) *Figures to the right side indicate full marks.*
- 4) *Use of calculator is allowed.*
- 5) *Assume suitable data jf necessary.*

Q1) a) Explain the importance of industrialization and sustainable development. [5]

b) Discuss about Environmental Policies and Regulations to encourage Pollution Prevention and Cleaner Production. [5]

Q2) a) Discuss the various Sustainability Strategies for pollution control and cleaner Production. [5]

b) Explain the cleaner technology and cleaner production concept. [5]

Q3) a) Discuss the historical evolution of pollution prevention and control. [5]

b) Explain the role of government and industry in pollution prevention and cleaner Production. [5]

Q4) a) Discuss the source reduction techniques in pollution control in chemical industries. [5]

b) Explain the applications of Internet Information pollution prevention and cleaner Production. [5]

P.T.O.

Q5) Explain the pollution prevention and control by following ways. **[10]**

- a) Reuse.
- b) Recover.
- c) Recycle.
- d) Raw material substitution.

Q6) Discuss in detail the role of total cost analysis in pollution prevention and cleaner production program. **[10]**

Q7) a) Write down about the Pollution Prevention and Cleaner Production Awareness Plan. **[5]**

b) Write a note on Environmental Audit. **[5]**

Q8) Write short notes on :

a) International Environmental Standards- ISO 14001. **[5]**

b) Elements of life cycle costing. **[5]**

